

RS-30

Single-axis robot Small size rotary type 30W



Model Specification Items

RS	Encoder type	30	Speed reduction ratio	Movement range	Applicable controller	Cable length	Options
Series	30: 30W	50: 1/50 100: 1/100	360: 360 degrees	T1: XSEL-J/K T2: SCON SSEL XSEL-P/Q	N: None S: 3m M: 5m X□□: Specified length	Refer to the options table below.	
A: Absolute specification I: Incremental specification							

Model Number/Specification

Model number	Encoder type	Motor output (W)	Speed reduction ratio	Movement range (degree)	Speed (degree/s)	Load inertia (Note1) (kg·m ²)	Rated torque (N·m)
RS-①-30-50-360-②-③-④-L	Absolute	30	1/50	0~360	1~360	0.0578	3.3
RS-①-30-100-360-②-③-④-L	Incremental		1/100		1~180		

* In the above model numbers, ① indicates the encoder type, ② indicates the applicable controller, ③ indicates the cable length, and ④ indicates the option(s).

Option

Name	Model number	Reference page	Notes
Key-slot option (output shaft)	K	Refer to the diagram below	
Home limit switch	L	Refer to the diagram below	Standard feature

* The home limit switch (L) is standard feature of the RS Series.

Common Specifications

Positioning repeatability	±0.028 degree
Speed reducer	Harmonic drive
Allowable dynamic load moment	9.8 N·m
Mass	2.0 kg
Applicable controller	T1: XSEL-J/K T2: XSEL-P/Q, SSEL, SCON
Cable length (Note 2)	N: None, S: 3m, M: 5m, X□□: Specified length
Ambient operating temperature/humidity	0 to 40°C, 85%RH (non-condensing)

Diagram

CAD drawings are available for download from our website.

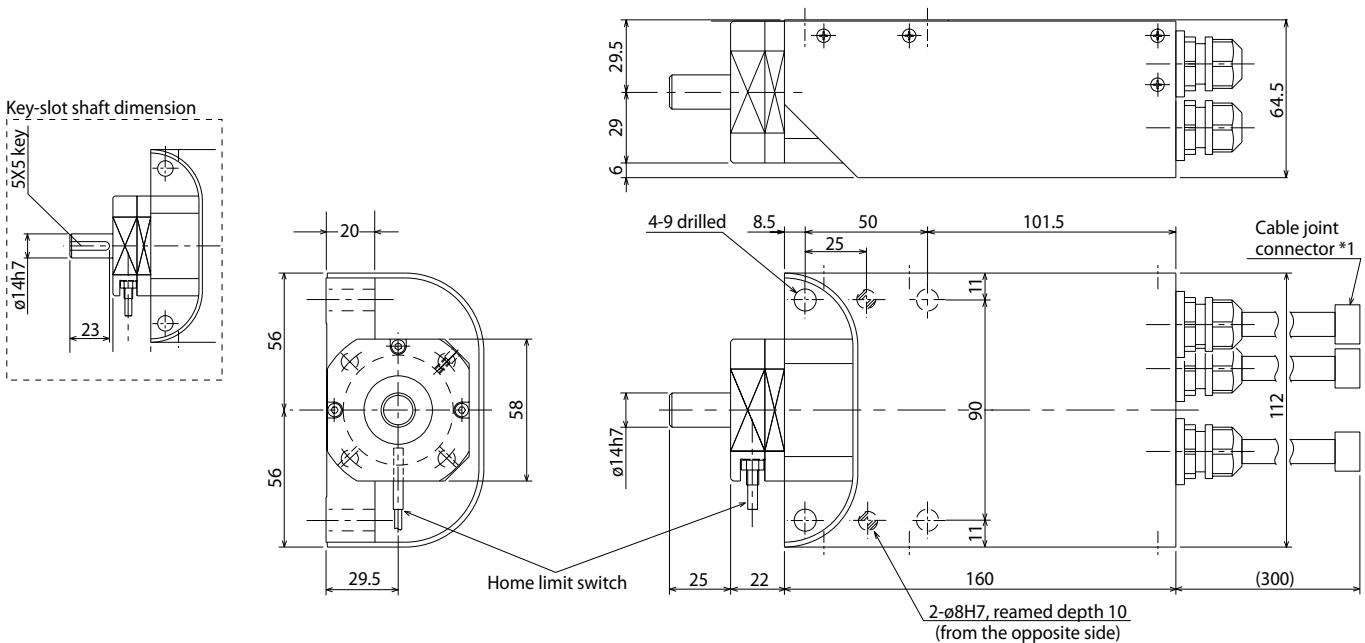

*1 Connect the motor cable, encoder cable, and limit switch cable. Refer to P. RS-4 & RS-5 for the cables.

Applicable Controller Specifications

Applicable Controller	Maximum number of controlled axes	Connectable encoder type	Operating method	Power-supply voltage	Reference page
X-SEL-P/Q	6 axes	Absolute/ incremental	Program	Single/three-phase 200 VAC	
X-SEL-J/K	4 axes			Single-phase 100/200 VAC	
SSEL	2 axes		Positioner pulse train control		
SCON	1 axis				



(Note 1) The load inertia is to be calculated based on the application conditions. The calculated load inertia is not to exceed the actuator's load inertia. (Please see P. RS-3 for further details.)

(Note 2) The maximum cable length is 30 m. Specify a desired length in meters. (Example. X08 = 8 m)

Rotary Shaft (RS Series) Selection Guide

For selecting the right RS Series model for your particular application, check the following points:

● Speed and Load Inertia

First, determine the actuator speed required in your application. Second, determine the load inertia based on the shape and the weight of the arm, chuck, or other end-effector to be attached to the rotating axis of your RS Series rotary actuator. Third, refer to the table below and select an actuator model with a larger load inertia than that required in your system.

Model	RS-30W		RS-60W	
	1/50	1/100	1/50	1/100
Speed Reduction Ratio	1/50	1/100	1/50	1/100
Rated Speed (degree/s)	360	180	360	180
Load Inertia kg·m ² (kgf·cm·s ²)	0.058 (0.59)	0.23 (2.35)	0.11 (1.1)	0.42 (4.3)

● Load Capacity and Load Inertia of the Motor

Load inertia is determined by the weight and the shape of the body, and is expressed as $J = \int r^2 dm$. The load inertia of a simple shaped body is expressed as $J = MK^2$.

With the RS Series rotary actuators, a rotating force is applied to the payload which causes it to spin around. This rotating force is expressed as torque. Torque is also called the moment of force. **In linear motion**, when force is applied to a weight (inertia), acceleration is generated in the direction of the force.

$$F = M \cdot a$$

F : Force N (kgf)
M : Weight (kg)
a : Acceleration (cm/s²)

In a rotational motion, when torque is applied to a body which has a load inertia, angular acceleration is generated. Therefore, the load capacity of a rotary actuator is expressed in terms of load inertia.

$$T = J \cdot \ddot{\omega}$$

T : Torque N·m (kgf·cm)
J : Load Inertia kg·m² (kgf·cm·s²)
 $\ddot{\omega}$: Angular Acceleration (rad/s²)

● Determining the Load Inertia of a Typical Shaped Body

J : Load Inertia (kg·m²) M : Load Weight (kg) r, a, a₁, a₂, b : Distance (m)

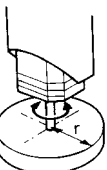
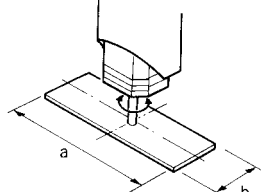
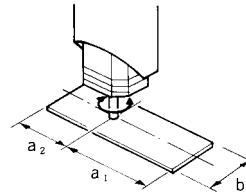
① Cylinder (includes Thin Circular Plate)	② Thin Rectangle (Rectangular Parallelepiped)	③ Thin Rectangle Plate (Rectangular Parallelepiped)
Rotating axis is at the center of the axis.	Rotating axis goes through the center of gravity of the plate, and is perpendicular to the axis.	Rotating axis goes through a point on the plate, which is perpendicular to the axis.
		
$J = M \cdot \frac{r^2}{2}$	$J = M \cdot \frac{a^2 + b^2}{12}$	$J = M_1 \cdot \frac{4a_1^2 + b^2}{12} + M_2 \cdot \frac{4a_2^2 + b^2}{12}$



● Guidelines for Rotary Actuator Model Selection

To select the right RS Series actuator for your application, consider the position of the payload to be attached to the output shaft of the actuator. Refer to the model selection guidelines below:

A. Payload is centered and located directly below the actuator.

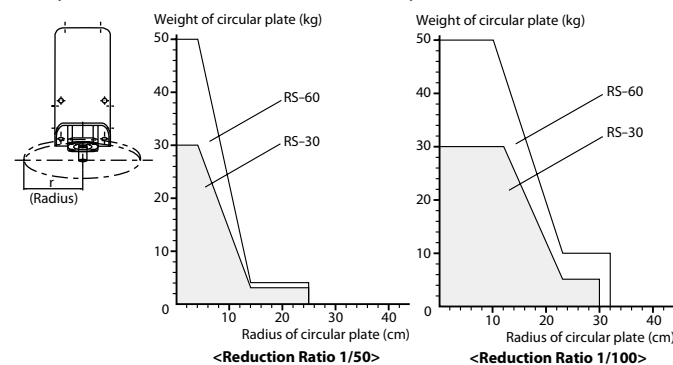

B. Payload is offset from the rotating axis shaft of the actuator.

