

RCS2-RA13R

RoboCylinder, Rod Type with Load Cell, Actuator Width 130mm
200V Servo Motor, Side-mounted Motor Specification

■ Models	RCS2	— RA13R —	□	— 750 —	□	— □ —	— T2 —	□	— □
Specification	Series	Type	Encoder type	Motor Type	Lead	Stroke	Applicable Controller	Cable length	Option
Items			I: Incremental specification A: Absolute specification	750: Servo motor, 750 W	2.5: Lead 2.5mm 1.25: Lead 1.25mm	50: 50mm 200: 200mm (The increment of stroke is 50mm)	T2: SCION-CB/CGB (Servo press specification)	N: No cable P: 1m S: 3m M: 5m X□□: Specified length R□□: Robot cable	Please refer to the options table below. * Please make sure to select an option code for both the motor side-mounted direction and the cable exit direction.

*Controller is not included.

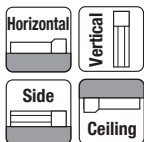

* Depending on the model, there may be some limitations to using the vertical mount position.

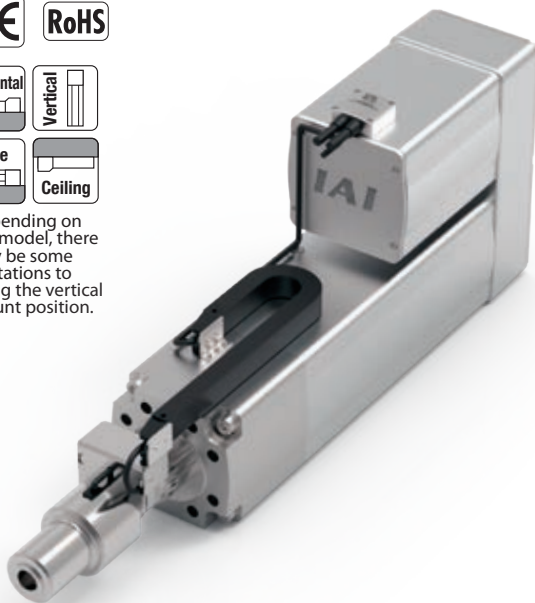

Correlation Diagram of Push Force and Current Limit

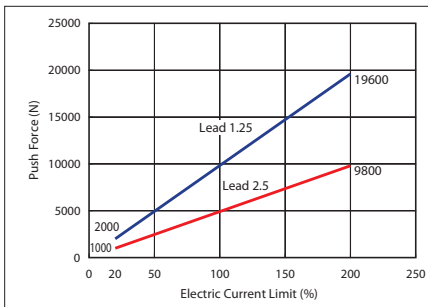

Caution:

- The correlation between push force and current limit value are strictly for reference purposes. Actual numbers may vary slightly.
- The current limit value should be 20% or more because the push force would be unstable when the current limit value is lower than 20%.

- POINT**
Note on selection
- (1) For push mode operation, please see P. 22 to check the allowable time period of a continuous push-motion with a different thrust force. Also, please check that the allowable continuous operational thrust force (please see P. 23) for the actual push cycle is less than the allowable continuous operational thrust force. (Even if there is no push motion)
 - (2) The value of the payload assumes an acceleration of 0.02 G when the lead is 2.5, or acceleration of 0.01 G when the lead is 1.25. The above value is at the max. acceleration.
 - (3) The value of the horizontal payload assumes that no external force is applied to the rod from any direction other than the moving direction.
 - (4) If the actuator comes with a brake (optional), the brake box (supplied with the brake) is required in addition to the actuator and controller.
 - (5) Force control is only for pushing motion, not valid for pulling motion.

Actuator Specifications

Lead and Payload

Model number	Motor (W)	Lead (mm)	Max. acceleration (G)	Max. payload Horizontal (kg)	Max. payload Vertical (kg)	Rated thrust (N)	Contin. push force (N)	Max. push force (N)*	Stroke (mm)
RCS2-RA13R-①-750-2.5-②-T2-③-④	750	2.5	0.02	15	15	5106	3567	9800	50~200 (every 50mm)
RCS2-RA13R-①-750-1.25-②-T2-③-④		1.25	0.01	15	15	10211	7141	19600	

Stroke and Maximum Speed

Lead (mm)	Stroke (mm)			
	50	100	150	200
2.5	85	120	125	
1.25	62			

Legend: ① Encoder type ② Stroke ③ Cable length ④ Option

* With 0.01-10mm/s

(Unit: mm/s)

Cable Length

Type	Cable code
Standard type	P (1m)
	S (3m)
	M (5m)
Special length	X06 (6m) ~X10 (10m)
	X11 (11m)~X15 (15m)
	X16 (16m)~X20 (20m)
	X21 (21m)~X25 (25m)
Robot cable	R01 (1m) ~R03 (3m)
	R04 (4m) ~R05 (5m)
	R06 (6m) ~R10 (10m)
	R11 (11m)~R15 (15m)
	R16 (16m)~R20 (20m)
	R21 (21m)~R25 (25m)

* Refer to P. 37 for maintenance cables.

Options

Name	Option code	Reference page
Front flange	FL	→P25
Foot bracket (*1)	FT	→P25
Brake (with brake box)	B	Refer to the RoboCylinder General Catalog.
Brake (without brake box)	BN	
Motor side-mounted to the top	MT1 /MT2/MT3	
Motor side-mounted to the right	MR1/MR2	
Motor side-mounted to the left	ML1/ML2	
Equipped with load cell (with cable track for the wiring) (*2)	LCT	-
Equipped with load cell (without cable track for the wiring) (*2)	LCN	-

(*1) Refer to P. 26 for the number of brackets included.

(*2) Please make sure to enter "LCT" or "LCN" in the box of Model Specification Items to select the actuator with load cell.

Actuator Specifications

Item	Description
Drive system	Ball screw Ø32mm, rolled C10
Positioning repeatability	±0.01mm
Rod non-rotation precision	±0 deg.
Lost motion	0.2mm or less
Load cell rated capacity	20000N
Load cell system accuracy	±1% R.C (*2)
Loading repeatability (*1)	±0.5% F.S (*3)
Load cell service life	2 million times
Ambient operating temperature and humidity	0°C~40°C

(*1) Ratio (in percentage) of the load variations caused by the repeated operations to the load cell rated capacity. The ratio is calculated based on actual data at IAI.

(*2) R.C: Rated Capacity

(*3) F.S: Full Scale

Dimensions

CAD drawings can be downloaded from our website. www.intelligentactuator.com

2/3D CAD

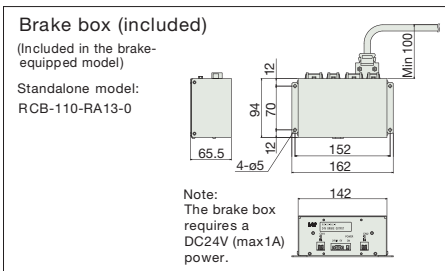
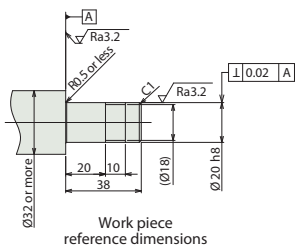
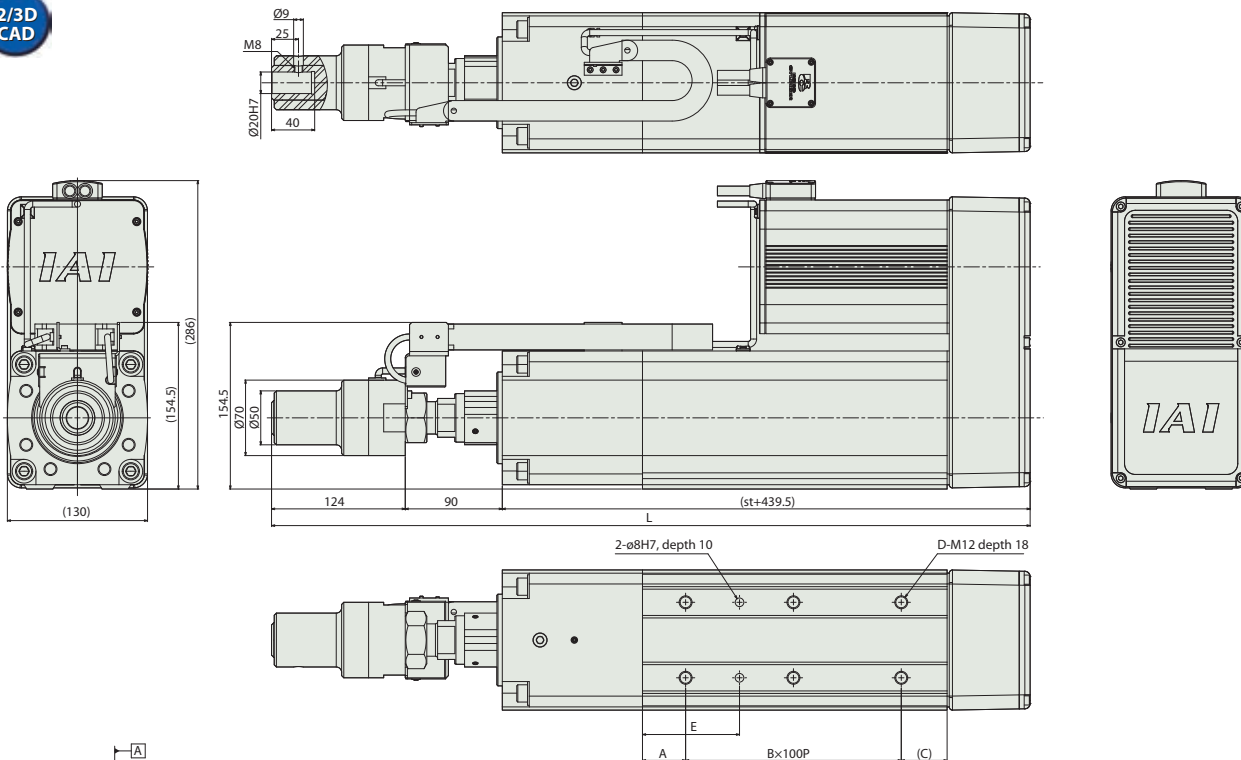

■ Dimensions and Mass by Stroke

Stroke	50	100	150	200	
L	Without brake	703.5	753.5	803.5	853.5
	With brake	760.5	810.5	860.5	910.5
A	40	65	40	65	
B	2	2	3	3	
C	42.5	67.5	42.5	67.5	
D	6	6	8	8	
E	90	115	90	115	
Mass (kg)	Without brake	35.5	36.5	37.5	38.5
	With brake	37.5	38.5	39.5	40.5

- *1 Connects the motor-encoder cable. Refer to P. 37 for the details of the cable.
- *2 While the rod is returning to its home position, please be careful of interference from surrounding objects, as it will travel until it reaches the ME.
- *3 The orientation of the bolt will vary depending on the product.

Note:
The brake-equipped model (option code: "-B") always comes with a brake box. If you want to order just the brake-equipped actuator, specify the option code "-BN".

Motor-mounting direction / Cable exit direction (Options)

Note:
Please be sure to specify one of the codes for the motor mounting direction and the cable exit direction.



Option Code	MT1	MT2	MT3	MR1	ML1	MR2	ML3
Motor-mounting direction	Top (standard)	Top	Top	Right	Left	Right	Left
Cable exit direction	Top (standard)	Right	Left	Top	Top	Right	Left

Compatible Controllers

RCS3-RA13R actuators can be operated with the following controllers. Select an appropriate controller type according to your application.

Name	External view	Model number (Note 1)	Max. number of controlled axes	Encoder type	Max. number of positioning points	Power-supply capacity	Description
Single axis controller (Standard type)		SCON-CB-750S①F-NP-2-2	1 axis	Absolute Incremental	512 points	Single-phase 200 VAC	Position standard type controller
Single axis controller (Global type)		SCON-CGB-750S①F-NP-2-2					Position global type controller (Safety category compliant spec.)

(Note 1) The model numbers are based on a 1-axis specification without network support. ① represents the encoder type (absolute/incremental). For details, refer to page 28.