

RCP5-RA7R ROBO Cylinder, Rod Type, Side-mounted Motor Type, Actuator Width 73mm, 24V Pulse Motor

Model	RCP5	RA7R	WA	56P					
Specification	Series	Type	Encoder type	Motor type	Lead	Stroke	Applicable controllers	Cable length	Options
Items			WA: Battery-less absolute specification	56P: Pulse motor, size 56□	24: 24mm 16: 16mm 8: 8mm 4: 4mm	70: 70mm 520: 520mm (Every 50mm)	P3: PCON/MSEL P5: RCON/RSEL	N: No cable P: 1m S: 3m M: 5m X□: Specified length R□: Robot cable	Please refer to the options table below.

*Controller is not included.

Radial Load Applicable

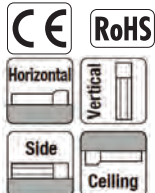

* Depending on the model, there may be some limitations to using the vertical mount position. Please refer to P.59 for details.

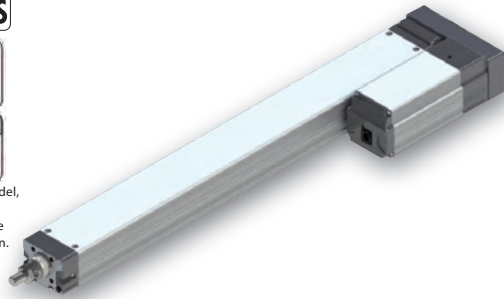

The figure above is the motor side-mounted to the left (ML).

POINT
Note on selection

- The actuator specification displays the payload's maximum value, but it will vary depending on the acceleration. Please refer to the "Selection Guidelines" (RCP5 Payload by Speed/Acceleration Table) on P. 61.
- Please refer to P. 59 for push-motion operation.
- The radial cylinder is equipped with a built-in guide. Please refer to the graphs shown in P. 65 and after for the allowable load mass.

Correlation Diagrams of Speed and Payload

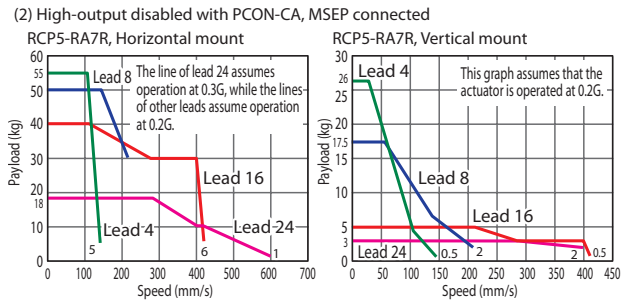
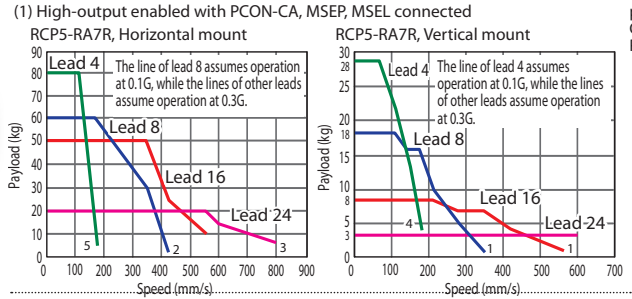

Actuator Specifications

Lead and Payload

Model number	Lead (mm)	Connected controller	Maximum payload		Maximum push force (N)	Stroke (mm)
			Horizontal (kg)	Vertical (kg)		
RCP5-RA7R-WA-56P-24-①-P3-②-③	24	High-output enabled	20	3	182	70~520 (Every 50mm)
		High-output disabled	18	3		
RCP5-RA7R-WA-56P-16-①-P3-②-③	16	High-output enabled	50	8	273	
		High-output disabled	40	5		
RCP5-RA7R-WA-56P-8-①-P3-②-③	8	High-output enabled	60	18	547	
		High-output disabled	50	17.5		
RCP5-RA7R-WA-56P-4-①-P3-②-③	4	High-output enabled	80	28	1,094	
		High-output disabled	55	26		

Legend: ① Stroke ② Cable length ③ Options *Please refer to P. 59 for push-motion operation.

Stroke and Maximum Speed

Values in brackets <> are for vertical use. (Unit: mm/s)

Lead (mm)	Connected controller	70~520 (Every 50mm)
24	High-output enabled	800 <600>
	High-output disabled	600 <400>
16	High-output enabled	560
	High-output disabled	420
8	High-output enabled	420 <350>
	High-output disabled	210
4	High-output enabled	175
	High-output disabled	140

① Stroke

Stroke (mm)	Standard price	Stroke (mm)	Standard price
70	-	320	-
120	-	370	-
170	-	420	-
220	-	470	-
270	-	520	-

③ Options

Name	Option code	Reference page	Standard price
Brake	B	→P. 11	-
Cable exit direction (Top)	CJT	→P. 11	-
Cable exit direction (Outside)	CJO	→P. 11	-
Cable exit direction (Bottom)	CJB	→P. 11	-
Flange	FL	→P. 12	-
Tip adapter (Flange)	FFA	→P. 12	-
Tip adapter (Internal thread)	NFA	→P. 13	-
Tip adapter (Keyway)	KFA	→P. 13	-
Motor side-mounted to the left (Standard)	ML	→P. 11	-
Motor side-mounted to the right	MR	→P. 11	-
Non-motor end specification	NM	→P. 11	-

Depending on the stroke, some rod attachment options are not available. Also, when selecting the shorter strokes, please be careful of nearby objects. Some interference may occur. Please refer to P. 14.

② Cable Length

Type	Cable code	Standard price
Standard type	P (1m)	-
	S (3m)	-
	M (5m)	-
Special length	X06 (6m) ~X10 (10m)	-
	X11 (11m)~X15 (15m)	-
	X16 (16m)~X20 (20m)	-
	R01 (1m) ~R03 (3m)	-
Robot cable	R04 (4m) ~R05 (5m)	-
	R06 (6m) ~R10 (10m)	-
	R11 (11m)~R15 (15m)	-
	R16 (16m)~R20 (20m)	-

*Please refer to P. 89 for maintenance cables.

Actuator Specifications

Item	Description
Drive system	Ball screw Ø12mm, rolled C10
Positioning repeatability (*1)	±0.02mm [±0.03mm]
Lost motion	0.1mm or less
Rod	Ø30mm Aluminum
Rod non-rotation precision (*2)	0 deg.
Allowable load and torque on rod tip	Refer to table in the page on the right, refer to P. 65
Rod tip overhang distance	100mm or less
Ambient operating temperature, humidity	0 to 40°C, 85% RH or less (Non-condensing)

(*1) The values in brackets [] are for Lead 24.

(*2) Rod's angular displacement in rotational direction with no applied load is shown.

Dimensions

CAD drawings can be downloaded from our website. www.intelligentactuator.com



- *1 When the rod is returning to its home position, please be careful of interference from surrounding objects, as it will travel until it reaches the ME.
- *2 The direction of width across flats varies depending on the product.
- *3 If the actuator is installed using the front housing and flange, make sure the actuator will not receive any external force.

ME: Mechanical end
SE: Stroke end

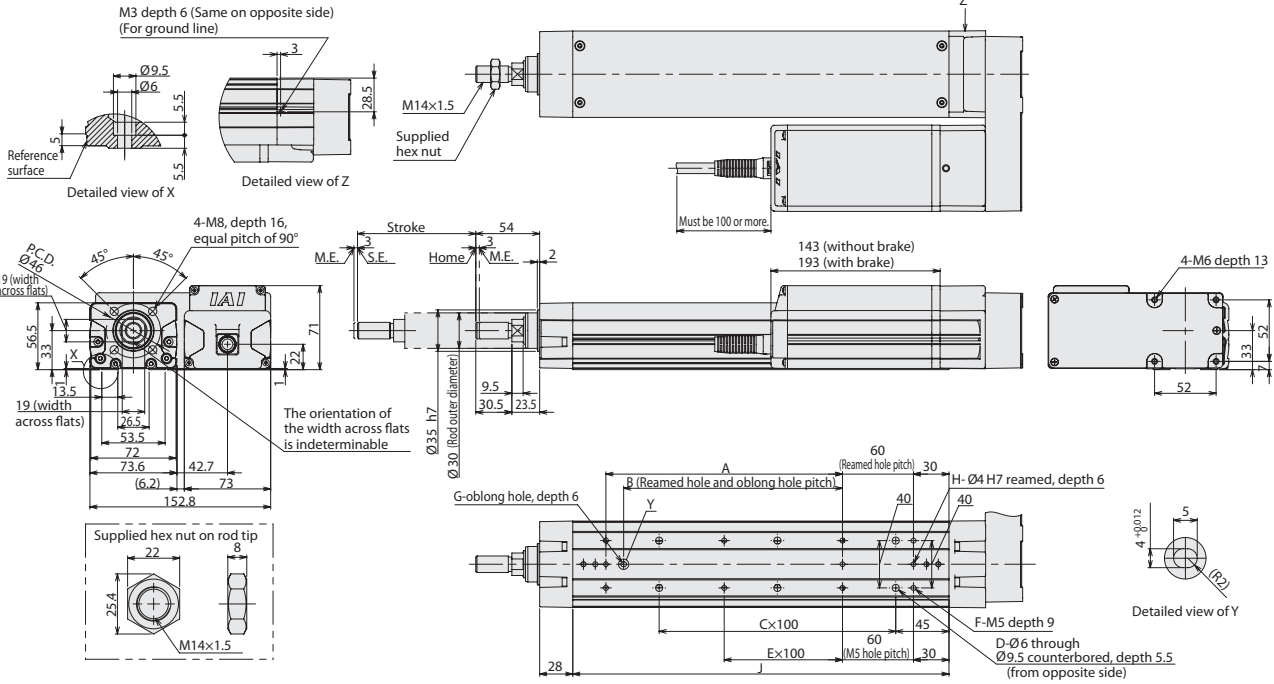

■ Cable Exit Direction (Option)

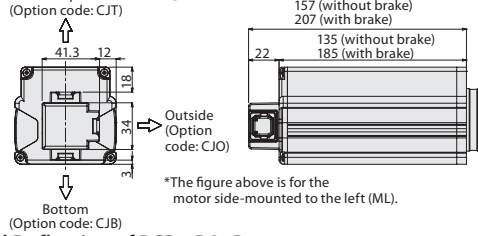

■ Rod Deflection of RCP5-RA7R

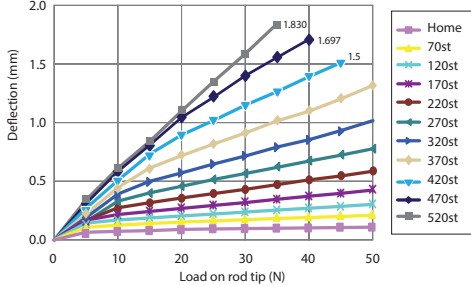

■ Dimensions and Mass by Stroke

Stroke	70	120	170	220	270	320	370	420	470	520
L	258	308	358	408	458	508	558	608	658	708
A	0	100	100	200	200	300	300	400	400	500
B	0	85	85	185	185	285	285	385	385	485
C	1	1	2	2	3	3	4	4	5	5
D	4	4	6	6	8	8	10	10	12	12
E	0	0	0	1	1	2	2	3	3	4
F	4	6	6	8	8	10	10	12	12	14
G	0	1	1	1	1	1	1	1	1	1
H	2	3	3	3	3	3	3	3	3	3
J	168	218	268	318	368	418	468	518	568	618
K	227	277	327	377	427	477	527	577	627	677
Allowable static load on rod tip (N)	119.2	97.7	82.8	71.6	63.0	56.2	50.6	46.0	42.2	38.8
Allowable dynamic load on rod tip (N)	Load offset 0mm	44.3	35.7	29.6	25.2	21.7	19.0	16.8	15.0	13.6
	Load offset 100mm	33.9	29.7	25.7	22.4	19.7	17.4	15.5	14.0	12.8
Allowable static torque on rod tip (N-m)	12.1	10.0	8.5	7.4	6.5	5.9	5.3	4.9	4.5	4.1
Allowable dynamic torque on rod tip (N-m)	Without brake	4.0	4.3	4.6	4.9	5.2	5.5	5.8	6.1	6.3
	With brake	4.5	4.8	5.1	5.4	5.7	6.0	6.3	6.6	6.8
Mass (kg)	Without brake	4.0	4.3	4.6	4.9	5.2	5.5	5.8	6.1	6.3
	With brake	4.5	4.8	5.1	5.4	5.7	6.0	6.3	6.6	6.8

Applicable Controllers

* Controller for RCP6 series is PCON, MSEL, RCON or RSEL.
Please refer our Controller General Catalog and/or contact IAI.