

RCP2CR-RTB/RTBL

Cleanroom ROBO Cylinder, Rotary, Medium Vertical Type,
50 mm Body Width, Pulse Motor

RCP2W-RTB/RTBL

Dust-proof/Splash-proof ROBO Cylinder, Rotary, Medium Vertical Type,
50 mm Body Width, Pulse Motor

Model Specification Items	RCP2CR RCP2W	Type	Encoder	Motor	Deceleration Ratio	Operating Range	Applicable Controllers	Cable Length	Options
	RTB: 330-degree rotation specification RTBL: Multi-rotation specification	I: Incremental * The Simple absolute encoder is also considered type "I."	28: Pulse motor 28□ size	20: Deceleration ratio 1/20 30: Deceleration ratio 1/30	330: 330 degrees (RTB only) 360: 360 degrees (RTBL only)	P1: PCON-CY/PL/PO/SE PSEL P3: PCON-CA PMEC/PSEP MSEP/MSEL	N: None P: 1m S: 3m M: 5m X□: Custom R□: Robot cable	NM: Reverse rotation specification SA: Shaft adapter TA: Table adapter	

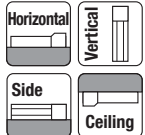

*Can be installed with above orientations.



Correlation Graph of Speed, Output Torque and Allowable Moment of Inertia

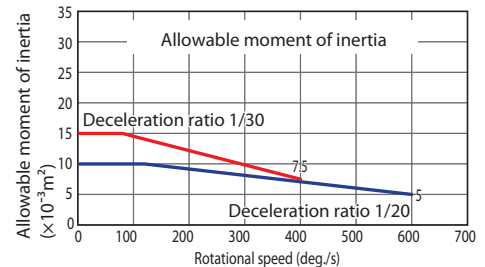
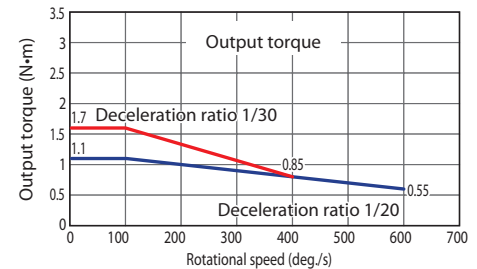

- POINT**
Note on selection
- The output torque gets lower as the rotation speed gets faster. Check the output torque graph on the right to see if the necessary speed for the application is possible.
 - The allowable moment of inertia on the rotated work piece will differ depending on the rotation speed. Check the allowable moment of inertia graph on the right to see if the necessary moment of inertia for the application is in the allowable range.
 - The rated acceleration while moving is 0.3 G.
 - Note that PMEC/PSEP Controllers are not capable of infinite rotation operation when used with multi-rotation actuators.

Actuator Specifications

Model	Deceleration Ratio	Maximum Torque (N·m)	Allowable Moment of Inertia (kg·m)	Operating Range (deg.)
RCP2 ①-RTB-I-28P-20-330-②-③-④	1/20	1.1	0.01	330
RCP2 ①-RTB-I-28P-30-330-②-③-④	1/30	1.7	0.015	
RCP2 ①-RTBL-I-28P-20-360-②-③-④	1/20	1.1	0.01	360
RCP2 ①-RTBL-I-28P-30-360-②-③-④	1/30	1.7	0.015	

Legend: ① Series ② Applicable controllers ③ Cable length ④ Options

Deceleration ratio and Max. speed

Deceleration Ratio	Operating Range	330/360 (deg.)
	1/20	600
1/30	400	

(Unit: deg./s)

Type

Type	Operating Range (deg.)	Standard Price
RTB	330	-
RTBL	360	-

③ Cable Length

Type	Cable Code	Standard Price	
		P3	P1
Standard Type	P (1 m)	-	-
	S (3 m)	-	-
	M (5 m)	-	-
Special Length	X06 (6 m) ~ X10 (10 m)	-	-
	X11 (11 m) ~ X15 (15 m)	-	-
	X16 (16 m) ~ X20 (20 m)	-	-
Robot Cable	R01 (1 m) ~ R03 (3 m)	-	Robot cable is standard for P1
	R04 (4 m) ~ R05 (5 m)	-	
	R06 (6 m) ~ R10 (10 m)	-	
	R11 (11 m) ~ R15 (15 m)	-	
	R16 (16 m) ~ R20 (20 m)	-	

④ Options

Name	Option Code	Reference	Standard Price
Reverse Rotation Specification	NM	See ROBO Cylinder	-
Shaft Adapter	SA	General Catalog	-
Table Adapter	TA	General Catalog	-

Actuator Specifications

Item	Description	
	Cleanroom	Dust-proof/Splash-proof
Drive System	Hypoid gear	
Positioning Repeatability	±0.01 deg.	
Home-return Accuracy	±0.01 deg. or less (RTB)/±0.05 deg. or less (RTBL)	
Lost Motion	±0.1 deg.	
Allowable Thrust Load	50 N	
Allowable Load Moment	3.9 N·m	
Ambient Operating Temperature/Humidity	0~40°C, 85% RH or less (non-condensing)	
Cleanliness	Class 10 (0.1 μm)	-
Pipe Joint for Vacuuming	Quick connect joint, applicable tube outer diameter ø6 mm	-
Air Vacuum Volume	15 NI/min	-
IP Code	-	IP54 or equivalent
Pipe Joint for Air Purge	Quick connect joint, applicable tube outer diameter ø6 mm	-
Air Purge Flow Volume	-	20 NI/min
Weight	0.96 kg	

Dimensions

CAD drawings can be downloaded from the website. www.intelligentactuator.com

2D
CAD

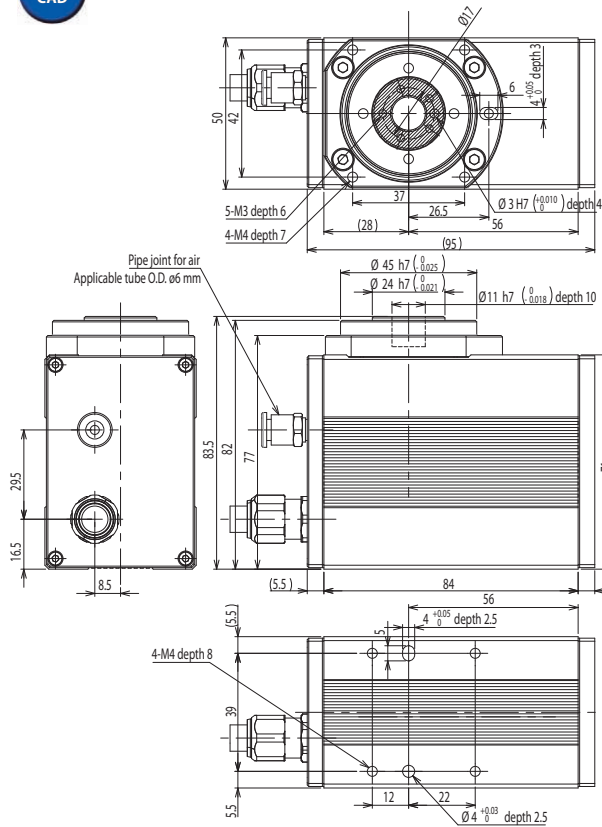

Note

*The shaded area in the top view shows the rotation area.

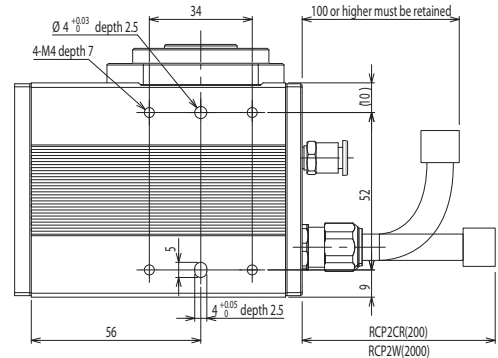

Note

The rotational part is shown in the home position of the top view, for both standard and reversed rotation (option) types.
At the home-return operation, standard type rotates to the left in the top view to return to home, and rotates to the right for operation after home-return operation is completed.
Reversed rotation type rotates to the right in the top view to return to home, and rotates to the left for operation after home-return operation is completed.
It is not possible to change the rotational direction after delivery due to structural reason.

② Applicable Controllers

The RCP2CR/RCP2W series actuators can operate with the controllers below. Select the controller according to your usage.

Name	External View	Model Number	Max. Number of Controlled Axes	Max. Pos. Points	Input Voltage	Standard Price
Solenoid Valve Multi-axis Type (PIO Specification)		MSEP- V - II - $\sim\sim$ - I -2-0	C:8 LC:6	3 points	DC24V	-
Solenoid Valve Multi-axis Type (Network Specification)		MSEP- V - II - $\sim\sim$ - III -0-0		256 points		
Positioner Type High-output Specification		PCON-CA-28P V - I -2-0	1	512 points		-
Pulse Train Type High-output Specification		PCON-CA-28PWA I -PL V -2-0		-		
Network Type High-output Specification		PCON-CA-28P V - III -0-0		768 points		
Program Control Type		PSEL-CS-1-28PI- I -2-0	2	1500 points		-
Program Control Multi-axis Type PIO Specification		MSEL-PC-1-28P V - I -2-4	4	30000 points	Single-phase AC 100V ~ 230V	-
Program Control Multi-axis Type Network Specification		MSEL-PC-1-28P V - III -0-4				
Program Control Multi-axis Type Safety Category Compliant Specification		MSEL-PG-1-28P V - I -2-4				
Program Control Multi-axis Type Safety Category Compliant Spec. w/ Network Board		MSEL-PG-1-28P V - III -0-4				
Other Connectable Devices	PSEP, PMEC, PCON-CY/PL/PO/SE					

*For the single-axis PSEL and MSEL. * I I/O type (NP/PN) * II Number of axes * III Field network specification code

* V Encoder type WAI: Incremental/SA: Simple absolute. However, WAI and SA cannot be used together for MSEL. * C (standard type) or LC (PLC function equipped type)

* N (NPN specification)/P (PNP specification) code