

RCA-RA4C

Robo Cylinder, Rod Type, ø37mm Diameter, 24V Servo Motor, Coupled

Model Specification Items	RCA	RA4C								
	Series	Type	Encoder type	Motor type	Lead	Stroke	Applicable controller	Cable length	Options	
	I: Incremental A: Absolute	20: 20W Servo motor 30: 30W Servo motor			12: 12mm 6: 6mm 3: 3mm	50: 50mm 300: 300mm (50mm pitch increments)	A1: ACON ASEL A3: AMEC ASEP MSEP	N: None P: 1m S: 3m M: 5m X□□: Custom Length R□□: Robot Cable	See Options below.	

* See page Pre-47 for details on the model descriptions.
* The absolute models are only compatible with ASEL. Simple absolute encoders are considered incremental.



For High Acceleration/Deceleration

Power-saving

(*1) Except all 20W models and 30W 3mm lead models

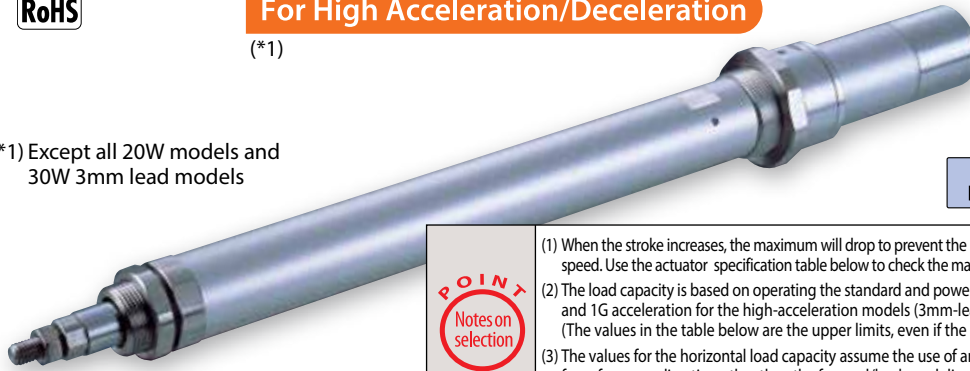

Technical References Appendix P.5



- When the stroke increases, the maximum will drop to prevent the ball screw from reaching the critical rotational speed. Use the actuator specification table below to check the maximum speed at the stroke you desire.
- The load capacity is based on operating the standard and power-saving models at 0.3G (0.2G for 3mm-lead), and 1G acceleration for the high-acceleration models (3mm-lead model excluded). (The values in the table below are the upper limits, even if the acceleration/deceleration is decreased.)
- The values for the horizontal load capacity assume the use of an external guide, so that there is no external force from any direction other than the forward/backward direction of the rod.
- See page A-71 for details on push motion.

Actuator Specifications

Leads and Payloads

Model number	Motor output (W)	Lead (mm)	Max. Load Capacity		Rated thrust (N)	Stroke (mm)
			Horizontal (kg)	Vertical (kg)		
RCA-RA4C-①-20-12-②-③-④-⑤	20	12	3.0	1.0	18.9	50~300 (every 50mm)
RCA-RA4C-①-20-6-②-③-④-⑤		6	6.0	2.0	37.7	
RCA-RA4C-①-20-3-②-③-④-⑤		3	12.0	4.0	75.4	
RCA-RA4C-①-30-12-②-③-④-⑤	30	12	4.0	1.5	28.3	
RCA-RA4C-①-30-6-②-③-④-⑤		6	9.0	3.0	56.6	
RCA-RA4C-①-30-3-②-③-④-⑤		3	18.0	6.5	113.1	

Stroke and Maximum Speed

Stroke Lead	Stroke	50~300 (every 50mm)
	12	600
6	300	300
3	150	150

(Unit: mm/s)

Code explanation ① Stroke ② Applicable controller ③ Cable length ④ Options *See page A-71 for details on push motion.

① Encoder Type/② Stroke

② Stroke (mm)	Standard price			
	① Encoder Type			
	Incremental		Absolute	
	Motor Output (W)		Motor Output (W)	
	20W	30W	20W	30W
50	—	—	—	—
100	—	—	—	—
150	—	—	—	—
200	—	—	—	—
250	—	—	—	—
300	—	—	—	—

⑤ Options

Name	Option code	See page	Standard price
Brake	B	→ A-42	—
Foot bracket	FT	→ A-49	—
Flange bracket (front)	FL	→ A-45	—
Flange bracket (back)	FLR	→ A-46	—
High-acceleration/deceleration (*1)	HA	→ A-50	—
Home sensor (*2)	HS	→ A-50	—
Power-saving (*3)	LA	→ A-52	—
Knuckle joint	NJ	→ A-53	—
Non-motor end specification	NM	→ A-52	—
Trunnion bracket (front)	TRF	→ A-57	—
Trunnion bracket (back)	TRR	→ A-58	—

(*1) The high-acceleration/deceleration option is not available for all the 20W models, not 30W with 3mm-lead model.
(*2) The home sensor (HS) cannot be used on the Non-motor end models.
(*3) The high-acceleration/deceleration option and the power-saving option cannot be used simultaneously.

④ Cable Length

Type	Cable symbol	Standard Price
Standard	P (1m)	—
	S (3m)	—
	M (5m)	—
Special length	X06 (6m) ~ X10 (10m)	—
	X11 (11m) ~ X15 (15m)	—
	X16 (16m) ~ X20 (20m)	—
Robot Cable	R01 (1m) ~ R03 (3m)	—
	R04 (4m) ~ R05 (5m)	—
	R06 (6m) ~ R10 (10m)	—
	R11 (11m) ~ R15 (15m)	—
	R16 (16m) ~ R20 (20m)	—

* See page A-59 for cables for maintenance.

Actuator Specifications

Item	Description
Drive System	Ball screw, ø10mm, rolled C10
Positioning Repeatability	±0.02mm
Lost Motion	0.1mm or less
Base	Material: Aluminum, white alumite treated
Rod diameter	ø20mm
Non-rotating accuracy of rod	±1.0 deg
Ambient operating temperature, humidity	0 to 40°C, 85% RH or less (Non-condensing)

- Slider Type
- Mini
- Standard
- Controllers Integrated
- Rod Type
- Mini
- Standard
- Controllers Integrated
- Table/ Arm/ Flat Type
- Mini
- Standard
- Gripper/ Rotary Type
- Linear Servo Type
- Clean-room Type
- Splash-Proof Type
- Pulse Motor
- Servo Motor (24V)
- Servo Motor (200V)
- Linear Servo Motor

Dimensional Drawings

CAD drawings can be downloaded from the website.

www.intelligentactuator.com

For Special Orders

Appendix P.15



- (*1) Connect the motor and encoder cables here. See page A-59 for details on cables.
- (*2) After homing, the slider moves to the ME, therefore, please watch for any interference with surrounding objects.
ME : Mechanical end SE : Stroke end
- (*3) The orientation of the bolt varies depending on the product.

Note:
Do not apply any external force on the rod from any direction other than the direction of the rod's motion. If a force is exerted on the rod in a perpendicular or rotational direction, the detent may become damaged.

[No Brake]

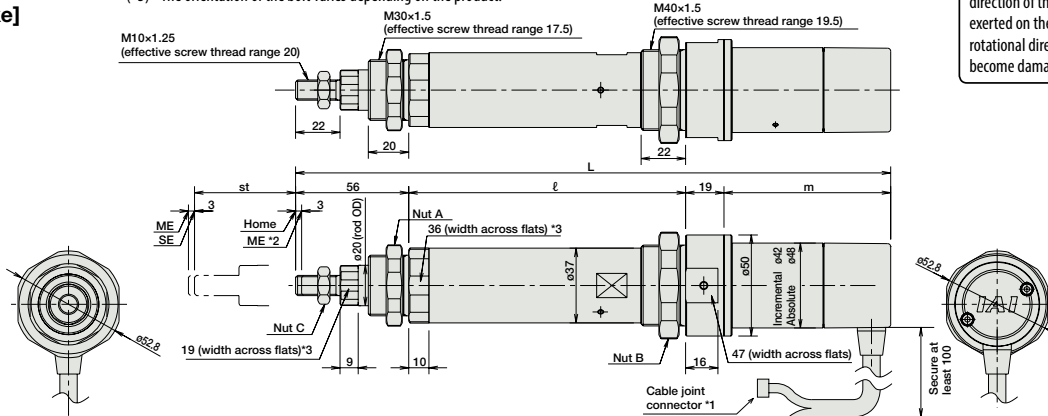

[Brake-Equipped]

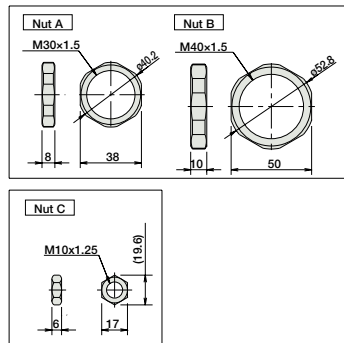
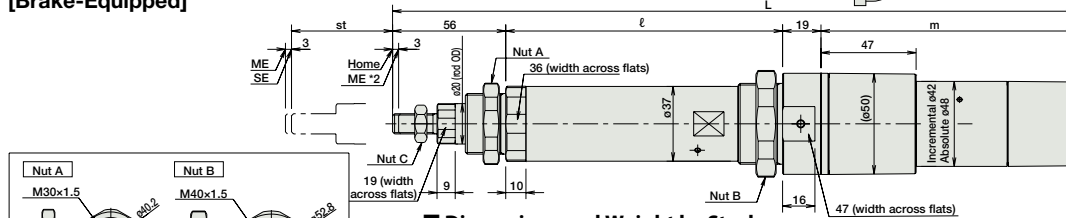

Dimensions and Weight by Stroke

RCA-RA4C (without brake)

Stroke	RCA-RA4C (without brake)						
	50	100	150	200	250	300	
L	20W	Incr. 279.5	329.5	379.5	429.5	479.5	529.5
	Absol.	292.5	342.5	392.5	442.5	492.5	542.5
L	30W	Incr. 294.5	344.5	394.5	444.5	494.5	544.5
	Absol.	307.5	357.5	407.5	457.5	507.5	557.5
ℓ		137	187	237	287	337	387
m	20W	Incr.		67.5			
	Absol.	Absol.		80.5			
m	30W	Incr.		82.5			
	Absol.	Absol.		95.5			
Weight (kg)		1.1	1.2	1.4	1.5	1.7	1.8

RCA-RA4C (with brake)

Stroke	RCA-RA4C (with brake)						
	50	100	150	200	250	300	
L	20W	Incr. 322.5	372.5	422.5	472.5	522.5	572.5
	Absol.	335.5	385.5	435.5	485.5	535.5	585.5
L	30W	Incr. 337.5	387.5	437.5	487.5	537.5	587.5
	Absol.	350.5	400.5	450.5	500.5	550.5	600.5
ℓ		137	187	237	287	337	387
m	20W	Incr.		110.5			
	Absol.	Absol.		123.5			
m	30W	Incr.		125.5			
	Absol.	Absol.		138.5			
Weight (kg)		1.3	1.4	1.6	1.7	1.9	2.0

Applicable Controllers

RCA series actuators can be operated with the controllers indicated below. Select the type according to your intended application. * ACON-CY also can be used.

Name	External view	Model number	Features	Maximum number of positioning points	Input power	Power-supply capacity	Standard price	Reference page
Solenoid Valve Type		AMEC-C-20I-2-1 AMEC-C-30I-2-1	Easy-to-use controller, even for beginners	3 points	AC100V	2.4A rated	—	→ P537
		ASEP-C-20I-2-0 ASEP-C-30I-2-0	Simple controller operable with the same signal as a solenoid valve					→ P547
Solenoid valve multi-axis type PIO specification		MSEP-C-IV-2-0	Positioner type based on PIO control, allowing up to 8 axes to be connected	256 points	DC24V	(Standard) 20W 1.3A rated 4.4A max. 30W 1.3A rated 4.4A max.	—	→ P563
Solenoid valve multi-axis type Network specification		MSEP-C-IV-0-0	Field network-ready positioner type, allowing up to 8 axes to be connected	512 points				
Positioner type		ACON-C-20I-2-0 ACON-C-30I-2-0	Positioning is possible for up to 512 points	512 points	DC24V	(Power-saving) 20W 1.3A rated 2.5A max. 30W 1.3A rated 2.2A max.	—	→ P631
Safety-Compliant Positioner Type		ACON-CG-20I-2-0 ACON-CG-30I-2-0						
Pulse Train Input Type (Differential Line Driver)		ACON-PL-20I-2-0 ACON-PL-30I-2-0	Pulse train input type with differential line driver support	(—)	DC24V	(Power-saving) 20W 1.3A rated 2.5A max. 30W 1.3A rated 2.2A max.	—	→ P631
Pulse Train Input Type (Open Collector)		ACON-PO-20I-2-0 ACON-PO-30I-2-0	Pulse train input type with open collector support					
Serial Communication Type		ACON-SE-20I-N-0-0 ACON-SE-30I-N-0-0	Dedicated Serial Communication	64 points	DC24V	(Power-saving) 20W 1.3A rated 2.5A max. 30W 1.3A rated 2.2A max.	—	→ P675
Program Control Type		ASEL-CS-1-20I-2-0 ASEL-CS-1-30I-2-0	Programmed operation is possible. Can operate up to 2 axes	1,500 points	DC24V	(Power-saving) 20W 1.3A rated 2.5A max. 30W 1.3A rated 2.2A max.	—	→ P675

* This is for the single-axis ASEL. * ① indicates encoder type (I: incremental, A: absolute) * Enter the code "HA" or "LA" in ② when the high-acceleration/deceleration option or the power-saving option is specified. * ③ indicates I/O type (NP/PN). * ④ indicates number of axes (1 to 8). * ⑤ indicates field network specification symbol.