

# NSA-MXMS

±10μm  
Standard

Battery-less  
Absolute

Body Width  
**130**  
mm

**200**  
W

**Model Specification Items**

<b>NSA</b>	<b>MXMS</b>	<b>WA</b>	<b>200</b>			<b>T2</b>		<b>AQ</b>	
Series	Type	Encoder Type	Motor Type	Lead	Stroke	Applicable Controllers	Cable Length	Options	
		WA Battery-less Absolute	200 200W	30 30mm 20 20mm	550 550mm 1500 1500mm (50mm increments)	T2 SCON MSCON SSEL XSEL-P/Q XSEL-RA/SA	N None S 3m M 5m X□□ Specified length	Refer to Options table below.	



Horizontal

Vertical

Side

Ceiling

Stroke			
Stroke (mm)	NSA-MXMS	Stroke (mm)	NSA-MXMS
550/600	○	1050/1100	○
650/700	○	1150/1200	○
750/800	○	1250/1300	○
850/900	○	1350/1400	○
950/1000	○	1450/1500	○

Options			
Name	Model	Reference Page	
AQ seal (equipped as standard) (Note 1)	<b>AQ</b>	4	
Standard cable track mounting direction (standard) (Note 2)	<b>CT3</b>	4	
Standard cable track mounting direction (opposite) (Note 2)	<b>CT4</b>	4	
Non-motor end specification	<b>NM</b>	4	
No cable track (standard) (Note 2)	<b>NT3</b>	4	
No cable track (opposite) (Note 2)	<b>NT4</b>	4	
User cable track mounting direction (standard) (Note 2)	<b>UM3</b>	4	
User cable track mounting direction (opposite) (Note 2)	<b>UM4</b>	4	

(Note 1) Be sure to fill in the Model Specification Items option column.  
 (Note 2) Be sure to fill in one of the codes in the Model Specification Items option column.

Cable Length		
Type	Cable Code	T2
Standard	<b>S</b> (3m)	○
	<b>M</b> (5m)	○
Specified length	<b>X06</b> (6m) ~ <b>X10</b> (10m)	○
	<b>X11</b> (11m) ~ <b>X15</b> (15m)	○
	<b>X16</b> (16m) ~ <b>X20</b> (20m)	○
	<b>X21</b> (21m) ~ <b>X25</b> (25m)	○
	<b>X26</b> (26m) ~ <b>X30</b> (30m)	○

(Note) This is a robot cable.  
 (Note) The encoder cable used differs depending on the cable length.  
 CB-X1-PA□□□ is for less than 20m and CB-X1-PA□□□-AWG24 for over 20m up to 30m.

(1) The payload in the "Main Specifications" indicates the maximum value. Please refer to the "Table of Payload by Speed/Acceleration" for more details.

(2) The center mass location of the mounted object should be less than half the overhang distance. Even when the overhang distance or load moment is within the allowable value, if abnormal vibration or noise is generated during operation, use less stringent operating conditions.

(3) The guideline for the overhang load length is 750mm or less in the Ma, Mb and Mc directions. Please refer to page 29 for more information regarding the overhang load length.

(4) Estimated allowable duty varies depending on the load factor. Please refer to P. 29 for more information.

Main Specifications

Item		Description	
Lead	Payload	Ball screw lead (mm)	30 20
		Max. payload (kg)	20 35
Horizontal	Speed/acceleration/ deceleration	Max speed (mm/s)	1800 1200
		Rated acceleration/deceleration (G)	0.3 0.3
		Max. acceleration/deceleration (G)	0.5 0.6
Stroke		Min. stroke (mm)	550 550
		Max. stroke (mm)	1500 1500
		Stroke pitch (mm)	50 50

Item	Description
Drive system	Ball screw $\phi$ 16mm rolled C5 or equivalent
Positioning repeatability	$\pm$ 0.01mm
Lost motion	0.02mm or less
Base	Material: Aluminum with white alumite treatment
Linear guide	Direct-acting infinite circulation type
Allowable static moment	Ma: 560N-m
	Mb: 800N-m
	Mc: 1,030N-m
Allowable dynamic moment (Note 3)	Ma: 123N-m
	Mb: 176N-m
	Mc: 227N-m
Ambient operating temp. & humidity	0 to 40°C, max. 85% RH or less (Non-condensing)
Degree of protection	-
Vibration resistance/shock resistance	4.9m/s <sup>2</sup> 100Hz or less
Compliant international standards	CE marking, RoHS Directive
Motor type	AC servo motor
Encoder type	Battery-less Absolute
Encoder pulse count	131072 pulse/rev

(Note 3) Assumes a standard rated life of 10,000km. The running life will vary depending on operation and installation conditions. Please contact IAI America to check the running life.

Slider Type Moment Direction

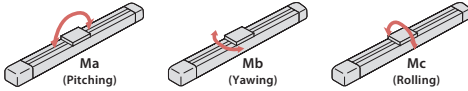

Table of Payload by Speed/Acceleration

The payload is in units of kg.

Lead (mm)	Max speed (mm/s)	Acceleration (G)			
		0.3	0.4	0.5	0.6
30	1800	20	10	5	-
20	1200	35	25	15	5

Stroke and Max Speed

Stroke	550~1500 (50mm increments)
Lead	
30	1800
20	1200

(Unit: mm/s)



**■ User Cable Track Mounting Direction (standard/UM3)**

(Note) Connect the motor cable and encoder cable to the cable joint connector.

Please refer to P.30 for more information on the cable.

(Note) When the slider is returning to its home position, please be careful of interference from surrounding objects, as it will travel until it reaches the M.E.

ST: Stroke  
M.E: Mechanical end  
S.E: Stroke end

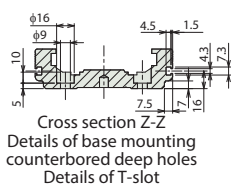
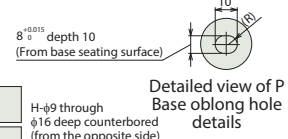
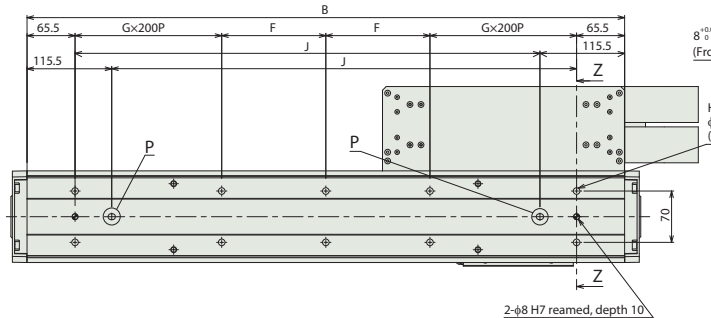
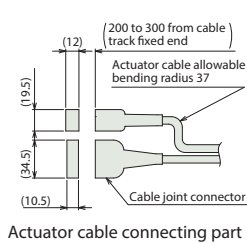
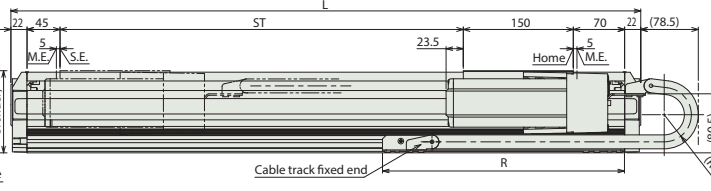
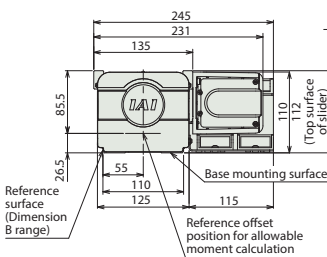
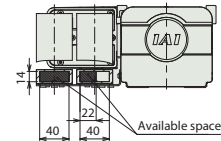
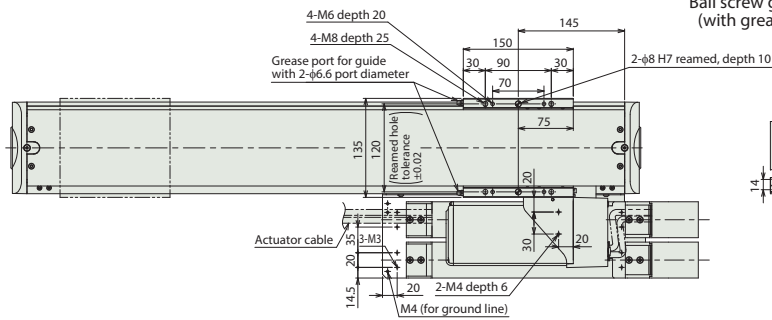
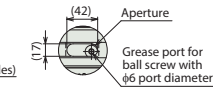
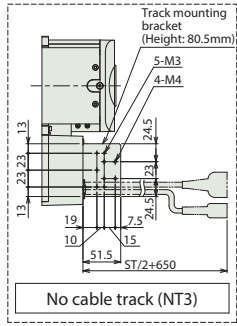

**■ Dimensions by Stroke**

Stroke	550	600	650	700	750	800	850	900	950	1000	1050	1100	1150	1200	1250	1300	1350	1400	1450	1500
L	859	909	959	1009	1059	1109	1159	1209	1259	1309	1359	1409	1459	1509	1559	1609	1659	1709	1759	1809
B	815	865	915	965	1015	1065	1115	1165	1215	1265	1315	1365	1415	1465	1515	1565	1615	1665	1715	1765
F	142	167	192	217	242	267	292	317	342	367	392	417	442	467	492	517	542	567	592	617
G	1	1	1	1	1	1	1	1	2	2	2	2	2	2	2	2	3	3	3	3
H	10	10	10	10	10	10	10	10	14	14	14	14	14	14	14	14	18	18	18	18
J	634	684	734	784	834	884	934	984	1034	1084	1134	1184	1234	1284	1334	1384	1434	1484	1534	1584
R	330	366	384	402	438	456	492	510	528	564	582	618	636	654	690	708	744	762	780	816

**■ Mass by Stroke**

Stroke	550	600	650	700	750	800	850	900	950	1000	1050	1100	1150	1200	1250	1300	1350	1400	1450	1500	
Mass (kg)	With user cable track	17.3	17.9	18.6	19.2	19.8	20.4	21.1	21.7	22.3	22.9	23.5	24.2	24.8	25.4	26.0	26.6	27.2	27.9	28.5	29.1
	No cable track	16.5	17.1	17.7	18.2	18.8	19.4	20.0	20.5	21.1	21.6	22.2	22.8	23.3	23.9	24.5	25.0	25.6	26.1	26.7	27.3

**■ Applicable Controllers**

The actuators on this page can be operated by the controllers indicated below. Please select the type depending on your intended use.

Name	External view	Max. number of connectable axes	Power supply voltage	Control method													Maximum number of positioning points	Reference page	
				Positioner	Pulse-train	Program	Network option *												
				DV	CC	CIE	PR	CN	ML	ML3	EC	EP	PRT	SSN	ECM				
MSCON-C		6	Single phase 100VAC/200VAC	-	-	-	●	●	-	●	●	-	●	●	-	-	256	Please contact IAI America for more information	
SCON-CAL/CGAL		1		●	-	-	●	●	-	●	●	-	●	●	-	-	512 (768 for network spec.)		
SCON-CB/CGB		1		●	●	-	●	●	●	●	●	●	●	●	●	-	-		512 (768 for network spec.)
SCON-LC/LCG		1		-	-	●	●	●	-	●	●	●	●	●	-	-	512 (768 for network spec.)		
SSEL-CS		2	●	-	●	●	●	-	●	-	-	-	●	-	-	20000			
XSEL-P/Q		6	Single phase 200VAC Three-phase 200VAC	-	-	●	●	●	-	●	-	-	-	●	-	-	20000		
XSEL-RA/SA		8		-	-	●	●	●	-	●	-	-	-	●	-	-	55000 (Depending on the type)		

(Note) For network abbreviations such as DV and CC, please contact IAI America.