

NSA-LXMM

±10μm
Battery-less Absolute
Multi Slider
Body Width 150mm
400W

Model Specification Items

NSA	LXMM	WA	400			T2		AQ	
Series	Type	Encoder Type	Motor Type	Lead	Stroke	Applicable Controllers	Cable Length	Options	
		WA Battery-less Absolute	400 400W	40 40mm 20 20mm	300 300mm 2250 2250mm (50mm increments)	T2 SCON SSEL XSEL-P/Q XSEL-RA/SA	N None S 3m M 5m X□□ Specified length	Refer to Options table below.	



CE
RoHS

Horizontal
Vertical
Side
Ceiling

Stroke			
Stroke (mm)	NSA-LXMM	Stroke (mm)	NSA-LXMM
300/350	○	1300/1350	○
400/450	○	1400/1450	○
500/550	○	1500/1550	○
600/650	○	1600/1650	○
700/750	○	1700/1750	○
800/850	○	1800/1850	○
900/950	○	1900/1950	○
1000/1050	○	2000/2050	○
1100/1150	○	2100/2150	○
1200/1250	○	2200/2250	○

POINT Selection Notes

- (1) The payload in the "Main Specifications" indicates the maximum value. Please refer to the "Table of Payload by Speed/Acceleration" for more details.
- (2) The center mass location of the mounted object should be less than half the overhang distance. Even when the overhang distance or load moment is within the allowable value, if abnormal vibration or noise is generated during operation, use less stringent operating conditions.
- (3) The guideline for the overhang load length is 900mm or less in the Ma, Mb and Mc directions. Please refer to page 29 for more information regarding the overhang load length.
- (4) Estimated allowable duty varies depending on the load factor. Please refer to P. 29 for more information.

Options		
Name	Model	Reference Page
AQ seal (equipped as standard) (Note 1)	AQ	4
Standard cable track mounting direction (standard) (Note 2)	CT3	4
No cable track (standard) (Note 2)	NT3	4
User cable track mounting direction (standard) (Note 2)	UM3	4

(Note 1) Be sure to fill in the Model Specification Items option column.
 (Note 2) Be sure to fill in one of the codes in the Model Specification Items option column.

Cable Length		
Type	Cable Code	T2
Standard	S (3m)	○
	M (5m)	○
Specified length	X06 (6m) ~ X10 (10m)	○
	X11 (11m) ~ X15 (15m)	○
	X16 (16m) ~ X20 (20m)	○
	X21 (21m) ~ X25 (25m)	○
	X26 (26m) ~ X30 (30m)	○

(Note) This is a robot cable.
 (Note) The encoder cable used differs depending on the cable length.
 CB-X1-PA□□□ is for less than 20m and CB-X1-PA□□□-AWG24 for over 20m up to 30m.

Main Specifications

Item		Description	
Lead	Ball screw lead (mm)	40	20
	Payload	Max. payload (kg)	40 80
Horizontal	Speed/acceleration/ deceleration	Max speed (mm/s)	2400 1300
		Rated acceleration/deceleration (G)	0.3 0.3
		Max. acceleration/deceleration (G)	0.8 0.9
Stroke	Min. stroke (mm)	300	300
	Max. stroke (mm)	2250	2250
	Stroke pitch (mm)	50	50

Item	Description
Drive system	Ball screw ϕ 20mm rolled C5 or equivalent
Positioning repeatability	\pm 0.01mm
Lost motion	0.02mm or less
Base	Material: Aluminum with white alumite treatment
Linear guide	Direct-acting infinite circulation type
Allowable static moment	Ma: 774N-m
	Mb: 1,106N-m
	Mc: 1,566N-m
Allowable dynamic moment (Note 3)	Ma: 162N-m
	Mb: 231N-m
	Mc: 327N-m
Ambient operating temp. & humidity	0 to 40°C, max. 85% RH or less (Non-condensing)
Degree of protection	-
Vibration resistance/shock resistance	4.9m/s ² 100Hz or less
Compliant international standards	CE marking, RoHS Directive
Motor type	AC servo motor
Encoder type	Battery-less Absolute
Encoder pulse count	131072 pulse/rev

(Note 3) Assumes a standard rated life of 10,000km. The running life will vary depending on operation and installation conditions. Please contact IAI America to check the running life.

Slider Type Moment Direction

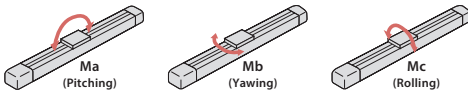

Table of Payload by Speed/Acceleration

The payload is in units of kg.

Lead (mm)	Max speed (mm/s)	Acceleration (G)						
		0.3	0.4	0.5	0.6	0.7	0.8	0.9
40	2400	40	30	20	15	10	7	-
20	1300	80	60	40	30	20	15	7

Stroke and Max Speed

Lead	Stroke	300~2250 (50mm increments)
40		2400
20		1300

(Unit: mm/s)

Standard Cable Track Mounting Direction (standard/CT3)

(Note) Connect the motor cable and encoder cable to the cable joint connector.
Please refer to P.30 for more information on the cable.

(Note) When the slider is returning to its home position, please be careful of interference from surrounding objects, as it will travel until it reaches the M.E.

ST: Stroke
M.E: Mechanical end

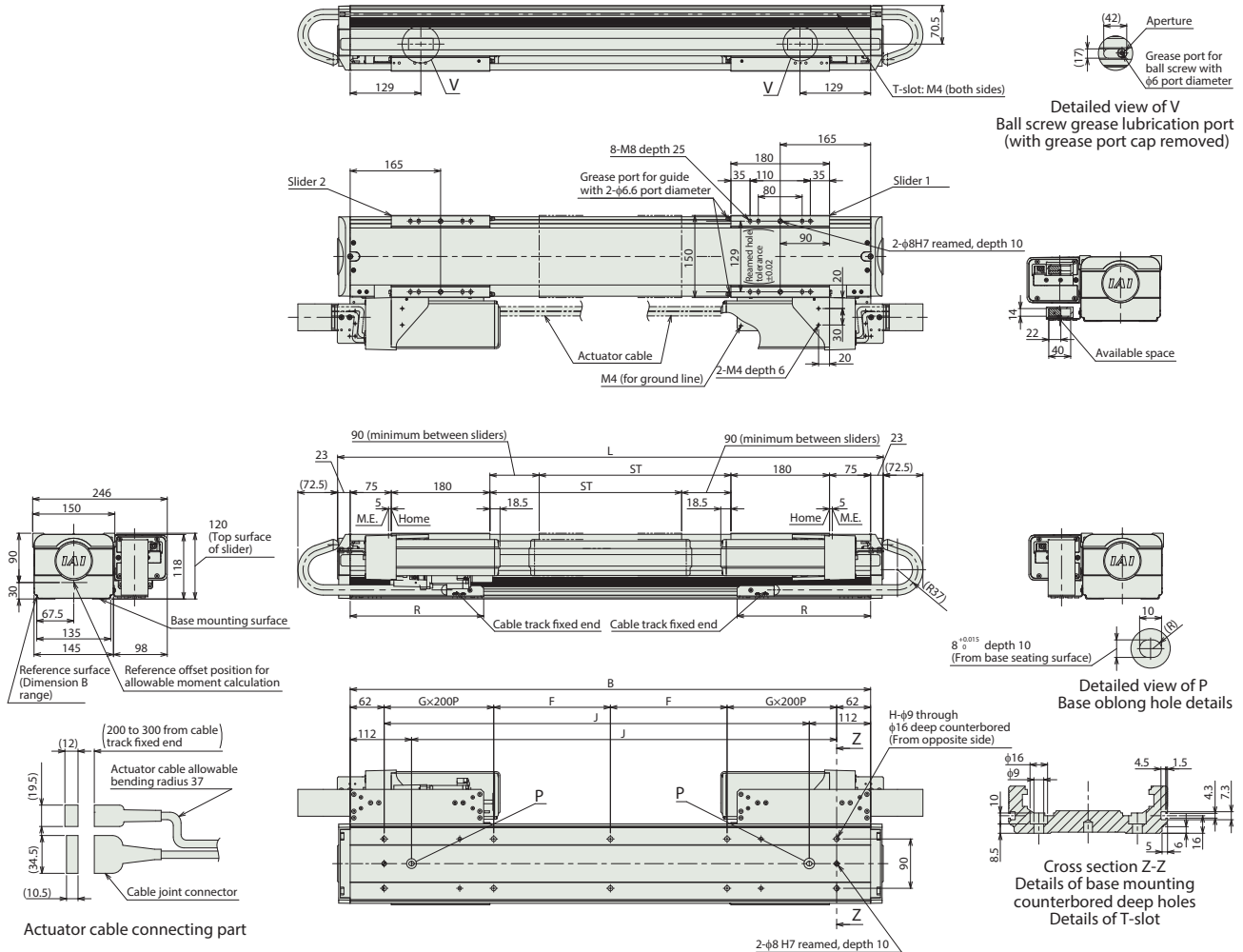

Dimensions by Stroke

Stroke	300	350	400	450	500	550	600	650	700	750	800	850	900	950	1000	1050	1100	1150	1200	1250	1300	1350	1400	1450	1500	1550	1600	1650	1700	1750	1800	1850	1900	1950	2000	2050	2100	2150	2200	2250		
L	946	996	1046	1096	1146	1196	1246	1296	1346	1396	1446	1496	1546	1596	1646	1696	1746	1796	1846	1896	1946	1996	2046	2096	2146	2196	2246	2296	2346	2396	2446	2496	2546	2596	2646	2696	2746	2796	2846	2896		
B	900	950	1000	1050	1100	1150	1200	1250	1300	1350	1400	1450	1500	1550	1600	1650	1700	1750	1800	1850	1900	1950	2000	2050	2100	2150	2200	2250	2300	2350	2400	2450	2500	2550	2600	2650	2700	2750	2800	2850		
F	188	213	238	263	288	313	138	163	188	213	238	263	288	313	138	163	188	213	238	263	288	313	138	163	188	213	238	263	288	313	138	163	188	213	238	263	288	313	138	163		
G	1	1	1	1	1	1	2	2	2	2	2	2	2	2	3	3	3	3	3	3	3	3	4	4	4	4	4	4	4	5	5	5	5	5	5	5	5	5	6	6		
H	10	10	10	10	10	10	14	14	14	14	14	14	14	14	18	18	18	18	18	18	18	18	22	22	22	22	22	22	22	22	26	26	26	26	26	26	26	26	26	26	30	30
J	726	776	826	876	926	976	1026	1076	1126	1176	1226	1276	1326	1376	1426	1476	1526	1576	1626	1676	1726	1776	1826	1876	1926	1976	2026	2076	2126	2176	2226	2276	2326	2376	2426	2476	2526	2576	2626	2676		
R	208	244	262	280	316	334	370	388	406	442	460	496	514	532	568	586	622	640	658	694	712	730	766	784	820	838	856	892	910	946	964	982	1018	1036	1072	1090	1108	1144	1162	1180		

Mass by Stroke

Stroke	300	350	400	450	500	550	600	650	700	750	800	850	900	950	1000	1050	1100	1150	1200	1250	1300	1350	1400	1450	1500	1550	1600	1650	1700	1750	1800	1850	1900	1950	2000	2050	2100	2150	2200	2250
Mass (kg)	31.3	32.1	32.8	33.6	34.4	35.2	36.0	36.8	37.5	38.3	39.1	39.9	40.7	41.4	42.3	43.0	43.8	44.6	45.4	46.2	47.0	47.7	48.5	49.3	50.1	50.9	51.7	52.5	53.3	54.0	54.8	55.6	56.4	57.2	58.0	58.8	59.6	60.3	61.1	61.9

■ User Cable Track Mounting Direction (standard/UM3)

(Note) Connect the motor cable and encoder cable to the cable joint connector.

Please refer to P.30 for more information on the cable.

(Note) When the slider is returning to its home position, please be careful of interference from surrounding objects, as it will travel until it reaches the M.E.

ST: Stroke
M.E: Mechanical end

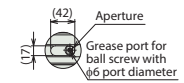
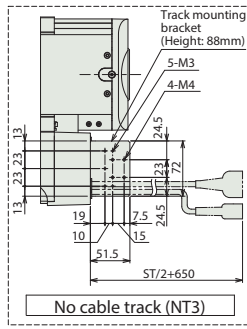

Detailed view of V Ball screw grease lubrication port (with grease port cap removed)

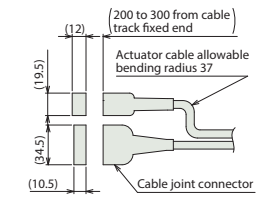
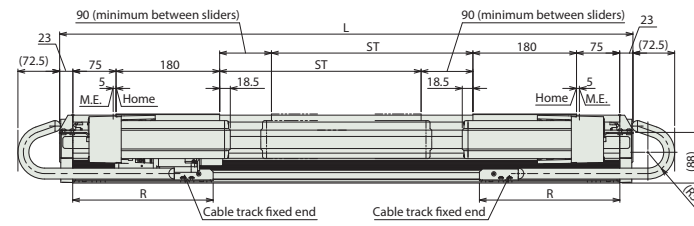
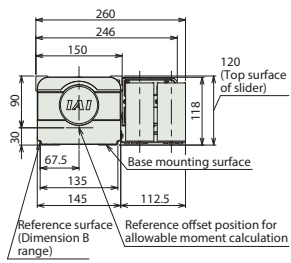
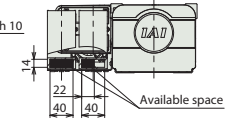
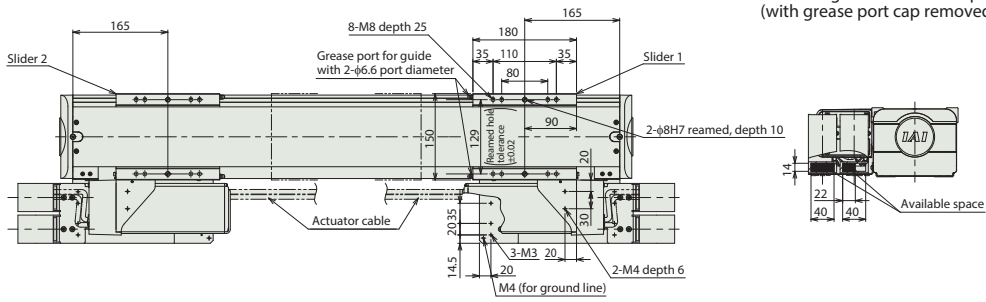

Actuator cable connecting part

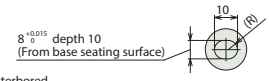
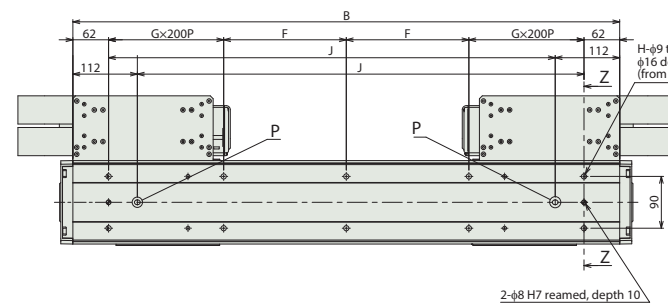

Detailed view of P Base oblong hole details

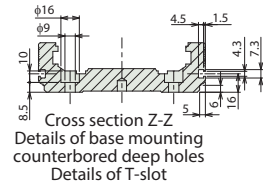

Cross section Z-Z Details of base mounting counterbored deep holes Details of T-slot

■ Dimensions by Stroke

Stroke	300	350	400	450	500	550	600	650	700	750	800	850	900	950	1000	1050	1100	1150	1200	1250	1300	1350	1400	1450	1500	1550	1600	1650	1700	1750	1800	1850	1900	1950	2000	2050	2100	2150	2200	2250	
L	946	996	1046	1096	1146	1196	1246	1296	1346	1396	1446	1496	1546	1596	1646	1696	1746	1796	1846	1896	1946	1996	2046	2096	2146	2196	2246	2296	2346	2396	2446	2496	2546	2596	2646	2696	2746	2796	2846	2896	
B	900	950	1000	1050	1100	1150	1200	1250	1300	1350	1400	1450	1500	1550	1600	1650	1700	1750	1800	1850	1900	1950	2000	2050	2100	2150	2200	2250	2300	2350	2400	2450	2500	2550	2600	2650	2700	2750	2800	2850	
F	188	213	238	263	288	313	138	163	188	213	238	263	288	313	138	163	188	213	238	263	288	313	138	163	188	213	238	263	288	313	138	163	188	213	238	263	288	313	138	163	
G	1	1	1	1	1	1	2	2	2	2	2	2	2	2	3	3	3	3	3	3	3	3	3	4	4	4	4	4	4	4	5	5	5	5	5	5	5	5	5	6	6
H	10	10	10	10	10	10	14	14	14	14	14	14	14	14	18	18	18	18	18	18	18	18	22	22	22	22	22	22	22	22	26	26	26	26	26	26	26	26	26	30	30
J	726	776	826	876	926	976	1026	1076	1126	1176	1226	1276	1326	1376	1426	1476	1526	1576	1626	1676	1726	1776	1826	1876	1926	1976	2026	2076	2126	2176	2226	2276	2326	2376	2426	2476	2526	2576	2626	2676	
R	208	244	262	280	316	334	370	388	406	442	460	496	514	532	568	586	622	640	658	694	712	730	766	784	820	838	856	892	910	946	964	982	1018	1036	1072	1090	1108	1144	1162	1180	

■ Mass by Stroke

Stroke	300	350	400	450	500	550	600	650	700	750	800	850	900	950	1000	1050	1100	1150	1200	1250	1300	1350	1400	1450	1500	1550	1600	1650	1700	1750	1800	1850	1900	1950	2000	2050	2100	2150	2200	2250
Mass (kg)	31.9	32.8	33.6	34.4	35.3	36.1	37.0	37.8	38.6	39.5	40.3	41.2	42.0	42.8	43.7	44.5	45.4	46.2	47.0	47.9	48.7	49.5	50.4	51.2	52.1	52.9	53.7	54.6	55.4	56.3	57.1	57.9	58.9	59.7	60.6	61.4	62.2	63.0	63.9	64.7
No cable track	30.9	31.6	32.4	33.1	33.9	34.6	35.3	36.0	36.8	37.5	38.2	39.0	39.7	40.4	41.2	41.9	42.6	43.4	44.1	44.9	45.6	46.3	47.0	47.8	48.5	49.2	50.0	50.7	51.5	52.2	52.9	53.6	54.4	55.1	55.8	56.6	57.3	58.0	58.8	59.5

■ Applicable Controllers

The actuators on this page can be operated by the controllers indicated below. Please select the type depending on your intended use.

Name	External view	Max. number of connectable axes	Power supply voltage	Control method																	Maximum number of positioning points	Reference page			
				Positioner	Pulse-train	Program	Network option *																		
							DV	CC	CIE	PR	CN	ML	ML3	EC	EP	PRT	SSN	ECM							
SCON-CB/CGB		1	Single phase 200VAC	●	●	-	●	●	●	●	●	●	●	●	●	●	●	●	●	●	●	-	-	512 (768 for network spec.)	Please contact IAI America for more information
SCON-LC/LCG		1		-	-	●	●	●	●	●	●	●	●	●	●	●	●	●	●	●	●	●	●	●	
SSEL-CS		2	Single phase 100VAC/200VAC	●	-	●	●	●	●	●	●	●	●	●	●	●	●	●	●	●	●	●	●	20000	
XSEL-P/Q		6	Single phase 200VAC	-	-	●	●	●	●	●	●	●	●	●	●	●	●	●	●	●	●	●	●	20000	
XSEL-RA/SA		8	Three-phase 200VAC	-	-	●	●	●	●	●	●	●	●	●	●	●	●	●	●	●	●	●	●	55000 (Depending on the type)	

(Note) For network abbreviations such as DV and CC, please contact IAI America.
(Note) The multi slider is controlled by a 2-axis controller or two SCON units.