

ISA-MXM-100 Single-Axis Robot: Medium X-Axis Long Slider Type, Actuator Width 120mm, 100W, Straight Shape

ISPA-MXM-100 Single-Axis Robot: Medium X-Axis Long Slider Type, Actuator Width 120mm, 100W, Straight Shape High-Precision Specification

Type Medium X-axis (120-mm wide) long slider type Stroke 100 ~ 1000mm Load capacity 80kg (horizontal)/19kg (vertical)



Model specification items Series Type Encoder type Motor output Lead Stroke Applicable controller Cable length Options
ISA[ISPA] - MXM - A - 100 - 20 - 1000 - T1 - S - B

* Refer to page 11 for the details of model specification items.

Models/Specifications

Model	Encoder type	Motor output (W)	Lead (mm)	Stroke (mm) In increments of 50mm (Note 1)	Speed (Note 2) (mm/s)	Acceleration (Note 3)				Load capacity (Note 3)				Rated thrust (N)
						Horizontal (G)		Vertical (G)		Horizontal (kg)		Vertical (kg)		
						Rated	Maximum	Rated	Maximum	Rated	Maximum	Rated	Maximum	
ISA [ISPA] -MXM-A-100-20-***-T1-△-□	Absolute	100	20	100 ~ 1000	1 ~ 1000	0.3	1.0	0.3	0.8	20	6	3.5	2	84.3
ISA [ISPA] -MXM-A-100-10-***-T1-△-□			10		1 ~ 500	0.3	0.6	0.3	0.5	40	20	9	7	169.5
ISA [ISPA] -MXM-A-100-5-***-T1-△-□			5		1 ~ 250	0.15	0.5	0.15	0.3	80	45	19	15	340.1
ISA [ISPA] -MXM-I-100-20-***-T1-△-□	Incremental	100	20	100 ~ 1000	1 ~ 1000	0.3	1.0	0.3	0.8	20	6	3.5	2	84.3
ISA [ISPA] -MXM-I-100-10-***-T1-△-□			10		1 ~ 500	0.3	0.6	0.3	0.5	40	20	9	7	169.5
ISA [ISPA] -MXM-I-100-5-***-T1-△-□			5		1 ~ 250	0.15	0.5	0.15	0.3	80	45	19	15	340.1

* In the above model names, *** indicates the stroke, △ the cable length and □ the applicable options.

*1.0G=9800mm/sec²

Options

Name	Code	Page	Name	Code	Page
AQ seal	AQ	P13	Master-axis designation	LM	P14
Brake	B	P13	Master-axis designation (sensor on opposite side)	LLM	P14
Creep sensor	C	P13	Reverse homing specification	NM	P14
Creep sensor on opposite side	CL	P13	Guide with ball-retaining mechanism	RT	P14
Home limit switch	L	P14	Slave-axis designation	S	P14
Home limit switch on opposite side	LL	P14			

Common Specifications

* Refer to page 10 for the details of common specification items.

Positioning repeatability (Note 4)	±0.02mm [±0.01mm]
Drive system (Note 5)	Ball screw ø16mm, rolled C10 [equivalent to rolled C5]
Lost motion (Note 6)	0.05mm or less [0.02mm or less]
Guide	integrated with base
Allowable static moment	Refer to page 242
Allowable dynamic moment	Ma: 69.6N•m Mb: 99.0N•m Mc: 161.7N•m
Overhang load length	Ma direction: 600mm or less, Mb/Mc directions: 600mm or less
Base	Material: Aluminum, with white alumite treatment
Cable length (Note 7)	N: None, S: 3m, M: 5m, X□: Specified length
Ambient operating temperature/humidity	0 to 40°C, 85%RH max. (non-condensing)

Dimensions

* Note that changing the home direction will require the actuator to be returned to IAI for adjustment.

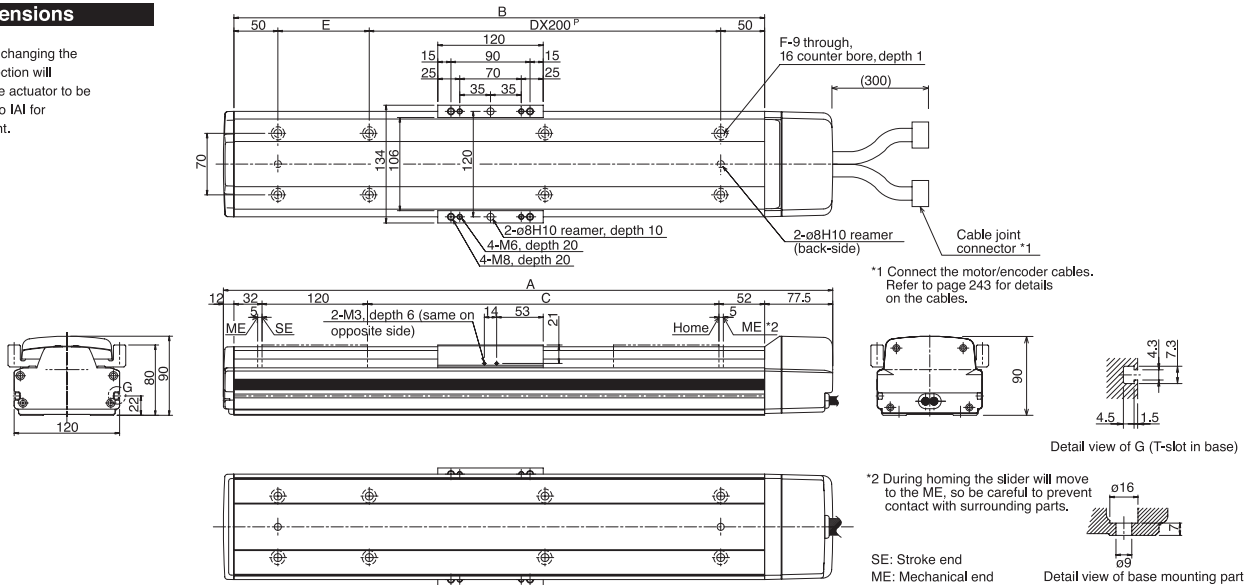

*1 Connect the motor/encoder cables. Refer to page 243 for details on the cables.

*2 During homing the slider will move to the ME, so be careful to prevent contact with surrounding parts.

Dimensions, Weight and Maximum Speed by Stroke

Stroke	100	(150)	200	(250)	300	(350)	400	(450)	500	(550)	600	(650)	700	(750)	800	(850)	900	(950)	1000		
A	393.5	443.5	493.5	543.5	593.5	643.5	693.5	743.5	793.5	843.5	893.5	943.5	993.5	1043.5	1093.5	1143.5	1193.5	1243.5	1293.5		
B	304	354	404	454	504	554	604	654	704	754	804	854	904	954	1004	1054	1104	1154	1204		
C	100	150	200	250	300	350	400	450	500	550	600	650	700	750	800	850	900	950	1000		
D	0	0	1	1	1	1	2	2	2	2	3	3	3	3	4	4	4	4	5		
E	204	254	104	154	204	254	104	154	204	254	104	154	204	254	104	154	204	254	104		
F	4	4	6	6	6	6	8	8	8	8	10	10	10	10	12	12	12	12	14		
Weight (kg)	6.2	6.7	7.2	7.7	8.3	8.8	9.3	9.8	10.4	10.9	11.4	11.9	12.5	13.0	13.5	14.0	14.6	15.1	15.6		
Maximum speed (mm/s)	Lead 20												1000	795		645		540			
	Lead 10												500	480		380		310		255	
	Lead 5												250	220		175		145		120	

Applicable Controller Specifications

Applicable controller	Maximum number of controlled axes	Compatible encoder type	Program operation	Positioner operation	Pulse-train control	Supply voltage	Page
X-SEL	4 axes	Absolute/incremental	○	△	×	AC100/200V	
E-Con	1 axis	Absolute/incremental	×	○	×	AC100/200V	
P-Driver	1 axis	Incremental	×	×	○	AC100/200V	



(Note 1) The strokes that are set in increments of 50 mm are semi-standard settings.
 (Note 2) A longer stroke will result in a lower maximum speed to prevent the ball screw from reaching a dangerous speed. (Refer to the above table for the maximum speed at a given stroke.)
 (Note 3) Refer to page 40 for the relationship of acceleration and load capacity. (Notes 4, 5, 6) The figures in brackets apply to the ISPA Series.
 Other specification values apply to both the ISA and ISPA Series.
 (Note 7) The maximum cable length is 30 m. Specify the desired length in meters (e.g., X08 = 8 m).

* Refer to page 9 for other points to note.