

# IAI

Quality and Innovation

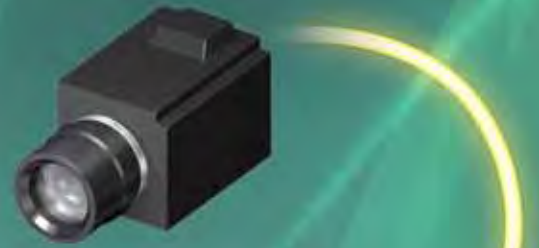

Now with Vision System Interface Function

# X-SEL Controller

You can now connect a vision system to your XSEL controller with ease.

## 1. Supporting leading vision systems that can be connected directly

You can use high-functional vision systems from manufacturers specialized in vision systems, such as Omron, Keyence and Cognex. Camera can capture up to 5 mega pixels.



## 2. No need for complex communication programs

Coordinates read by the camera are stored as position data in the robot controller according to dedicated commands. You don't need any complex communication programs.

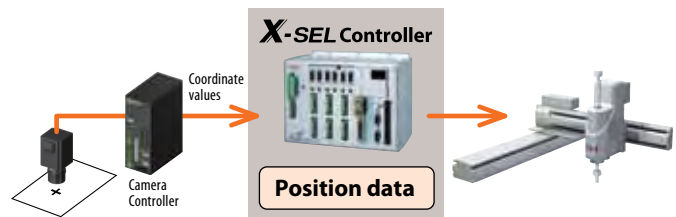

## 3. Easy adjustment (calibration)

Robot coordinates and camera coordinates can be aligned (calibrated) easily on the dedicated screen of your PC software.

## 4. Choice for affixing the camera

The camera can be mounted either directly to the robot or to an external location.

[www.intelligentactuator.com](http://www.intelligentactuator.com)

### ■ Connectable Vision Systems

Examples of vision system models					
Manufacturer	Model			Interface	
Cognex	In-Sight5000 series			Ethernet	
Omron	F210-C10	FZ3	—	RS232C	
Keyence	CV2000	CV3000	CV5000	XG-7000	Ethernet RS232C

### ■ IAI Equipment Needed to Connect a Vision System

- XSEL-P/Q controller  
(Main application firmware version 1.05 or later)
- Ethernet board  
(Optional --- Required if Ethernet is used for communication between the vision system and XSEL)
- XSEL controller PC software  
(Version 7.06.08.00 or later)

### ■ Application

Randomly oriented parts are picked up from a tray and placed in a box.

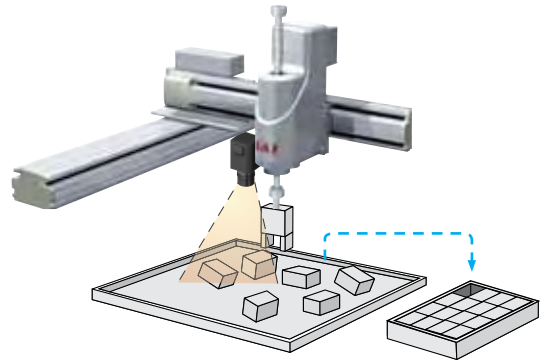

### ■ System Configuration (Example of Wiring with Omron's Vision System FZ3) \* Contact IAI for details.

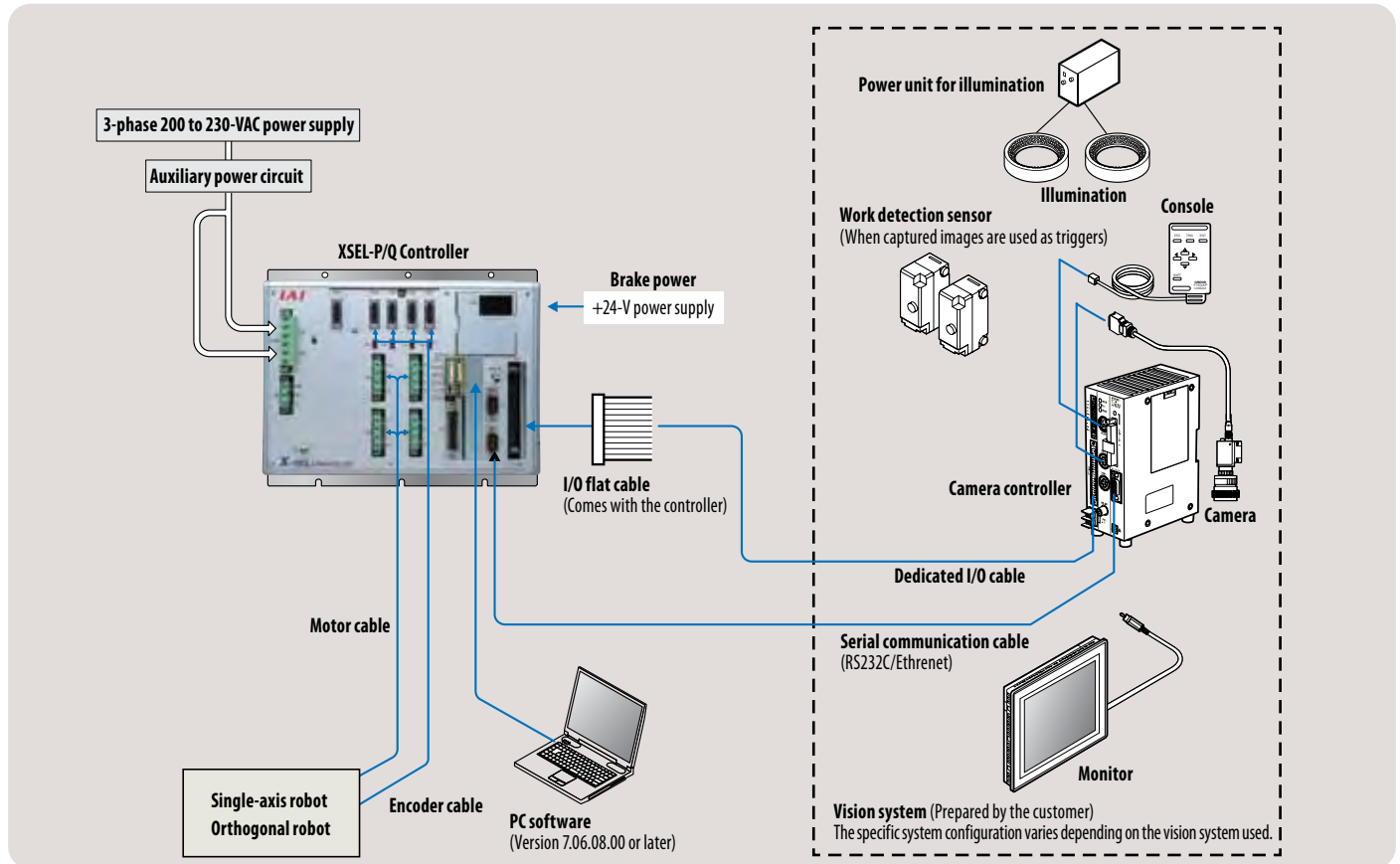

#### IAI America, Inc.

**Headquarters:** 2690 W. 237th Street, Torrance, CA 90505 (800) 736-1712  
**Chicago Office:** 1261 Hamilton Parkway, Itasca, IL 60143 (800) 944-0333  
**Atlanta Office:** 1220 Kennestone Circle, Suite 108, Marietta, GA 30066 (888) 354-9470

#### IAI Industrieroboter GmbH

Ober der Roth 4, D-65824 Schwalbach am Taunus, Germany

[www.intelligentactuator.com](http://www.intelligentactuator.com)

