

ROBO Cylinder  
Short Body Type

# RCS2-SRA7

Introducing the new compact rod type ROBO Cylinder  
**21.5mm\*** shorter than the previous model.

\*1 100W, 100mm stroke

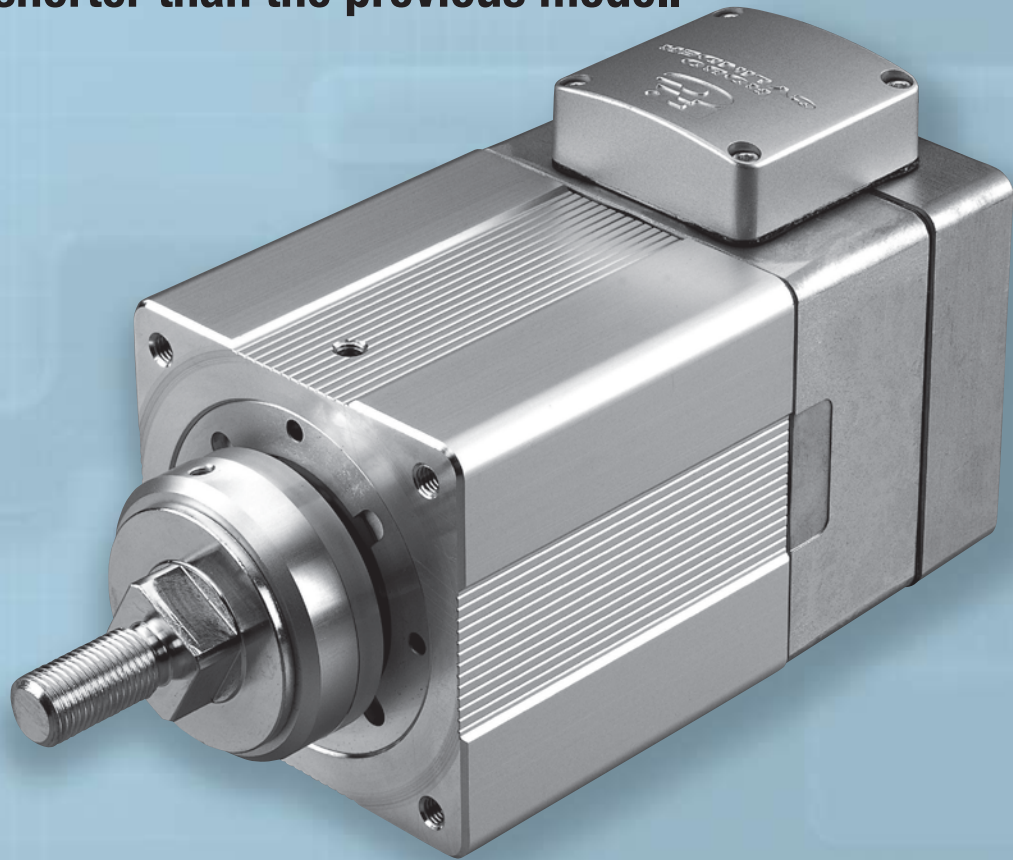

## Features

- 1** The RCS2-SRA7 can be used in applications with even tighter space constraints because the total length is shorter than the previous model by up to 21.5mm.  
(\*1) 100W, 100mm stroke RCS2-RA7BD
- 2** The mounting holes are located in the same positions as those in the previous model (\*2)  
(\*2) RCS2-RA7BD
- 3** The RCS2-SRA7 rod is also available with the extended rod end specification in which the length between the mounting hole and the rod end is the same as that of the previous model.  
(In the standard specification, the rod end is located closer to the unit than in the previous model.)

## Model Designation

<b>RCS2</b>	<input type="text"/>	<b>I</b>	<input type="text"/>	<input type="text"/>	<input type="text"/>	<input type="text"/>	<input type="text"/>	<input type="text"/>
Series	Type	Encoder Model	Motor Type	Ball Screw Lead	Stroke	Applicable Controller	Cable Length	Option
	<b>SRA7BD:</b> Short, Rod Type Standard Type	I: Incremental	60 : Servo Motor 60W	16 : 16mm 8 : 8mm	50 : 50mm ~	T1 : XSEL-J/K T2 : SCON SSEL XSEL-P/Q	N: No Cable P: 1m S: 3m M: 5m X <input type="checkbox"/> :Specified Length R <input type="checkbox"/> :Robot Cable	See the price List of Options below
	<b>SRGS7BD:</b> Short, Rod Type Single-guided Type		100 : Servo Motor 100W	4 : 4mm	300 : 300mm (Set in 50mm pitch)			
	<b>SRGD7BD:</b> Short, Rod Type Double-guided Type		150 : Servo Motor 150W					

## Actuator Model Specifications

	Model	Motor Output (W)	Lead (mm)	Max Speed (mm/s)	Rated Acceleration (G)	Load Capacity @ Rated Acc.		Max Acceleration (G)	Load Capacity @ Max Acc.		Rated Thrust (N)	Stroke (mm)
						Horizontal (kg)	Vertical (kg)		Horizontal (kg)	Vertical (kg)		
Standard Type	RCS2-SRA7BD-I-60 -①-②-③-④-⑤	60	16	800	0.25	5	2.0	0.35	2.5	1.0	63	50~300
			8	400	0.15	10	5.0	0.25	5.0	2.5	127	
			4	200	0.05	20	10.0	0.15	10.0	5.0	254	
	RCS2-SRA7BD-I-100 -①-②-③-④-⑤	100	16	800	0.30	10	3.5	0.4	5.0	1.5	103	
			8	400	0.20	22	9.0	0.3	10.0	4.5	207	
			4	200	0.10	40	19.5	0.2	20.0	9.0	414	
	RCS2-SRA7BD-I-150 -①-②-③-④-⑤	150	16	800	0.30	15	6.5	0.4	7.5	3.0	157	
			8	400	0.20	35	14.5	0.3	17.5	7.0	314	
			4	200	0.10	55	22.5	0.2	27.5	11.0	628	
Single Guide Type	RCS2-SRGS7BD-I-60 -①-②-③-④-⑤	60	16	800	0.25	5	1.5	0.35	2.5	0.5	63	50~300
			8	400	0.15	10	4.5	0.25	5.0	2.0	127	
			4	200	0.05	20	9.5	0.15	10.0	4.5	254	
	RCS2-SRGS7BD-I-100 -①-②-③-④-⑤	100	16	800	0.30	10	3.0	0.4	5.0	1.0	103	
			8	400	0.20	22	8.5	0.3	10.0	4.0	207	
			4	200	0.10	40	19.0	0.2	20.0	8.5	414	
	RCS2-SRGS7BD-I-150 -①-②-③-④-⑤	150	16	800	0.30	15	6.0	0.4	7.5	2.5	157	
			8	400	0.20	35	14.0	0.3	17.5	6.5	314	
			4	200	0.10	55	22.0	0.2	27.5	10.5	628	
Double Guide Type	RCS2-SRGD7BD-I-60 -①-②-③-④-⑤	60	16	800	0.25	5	1.0	0.35	2.5	—	63	50~300
			8	400	0.15	10	4.0	0.25	5.0	1.5	127	
			4	200	0.05	20	9.0	0.15	10.0	4.0	254	
	RCS2-SRGD7BD-I-100 -①-②-③-④-⑤	100	16	800	0.30	10	2.5	0.4	5.0	0.5	103	
			8	400	0.20	22	8.0	0.3	10.0	3.5	207	
			4	200	0.10	40	18.5	0.2	20.0	8.0	414	
	RCS2-SRGD7BD-I-150 -①-②-③-④-⑤	150	16	800	0.30	15	5.5	0.4	7.5	2.0	157	
			8	400	0.20	35	13.5	0.3	17.5	6.0	314	
			4	200	0.10	55	21.5	0.2	27.5	10.0	628	

Explanation of codes:① Lead ② Stroke ③ Applicable Controller ④ Cable Length ⑤ Option

## Actuator Specifications

Item	Description		
	Standard Type	Single Guide Type	Double Guide Type
Drive Method	Ball Screw $\phi$ 12mm Rolled C10		
Positioning Repeatability	$\pm 0.02$ mm		
Lost Motion	0.1mm or less		
Base	Material: Aluminum with white alumite treatment		
Rod non-rotating precision	-	$\pm 0.1$ Deg	$\pm 0.08$ Deg
Ambient air temp/humidity	0~40°C, 85% RH or below (non-condensing)		

## Options

Name	Option
Cable Exit Direction	A1~A3
Brake	B
Flange	FL
Foot Bracket	FT
Mounting Guide Direction	GS2~GS4
Extended Rod End Specification	RE

\* RE (extended rod end) specification is available as an option to provide compatibility in size with the previous RCS2-RA7BD. The user should specify this option when the dimension between the mounting hole and the rod end is the same as that of the RA7BD.

\* Please be aware that the home position cannot be reversed.

## Cable Length

Type	Cable Code
Standard Type	P (1m)
	S (3m)
	M (5m)
Special Length	X06 (6m)~X10 (10m)
	X11 (11m)~X15 (15m)
	X16 (16m)~X20 (20m)
Robot Cable	R01 (1m)~R03 (3m)
	R04 (4m)~R05 (5m)
	R06 (6m)~R10 (10m)
	R11 (11m)~R15 (15m)
	R16 (16m)~R20 (20m)

## Precautions for use

- When operated at the rated acceleration, refer to the above table under "Load Capacity @ Rated Acc." for maximum load capacity.
- When operated at the maximum acceleration, refer to the above table under "Load Capacity @ Max Acc." for maximum load capacity.
- When the application demands rotational moment, choose the actuator equipped with the guide(s) when 'non-rotating precision' is required. Please refer to the "Actuator Specification" table for detailed specifications.
- In the Standard Type ROBO Cylinder, rod run out may occur with a greater stroke. If rod run out will be a problem, the user should choose a type of cylinder equipped with guide(s) or add guide(s).

## Outline Drawings of Standard Type

Do not apply external force to the rod from any direction other than the direction of the rod travel. If force is applied to the rod in a direction perpendicular to the rod or in a direction of rod rotation, it may damage the actuator.

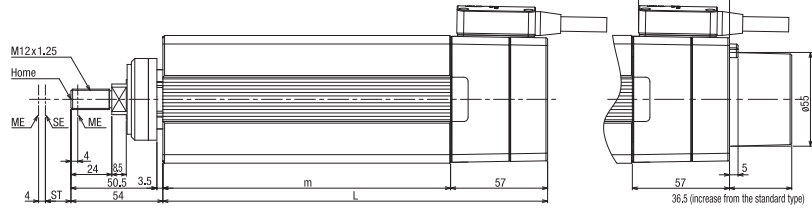
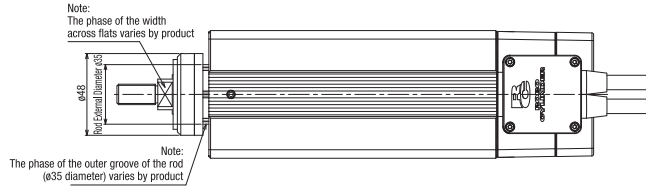
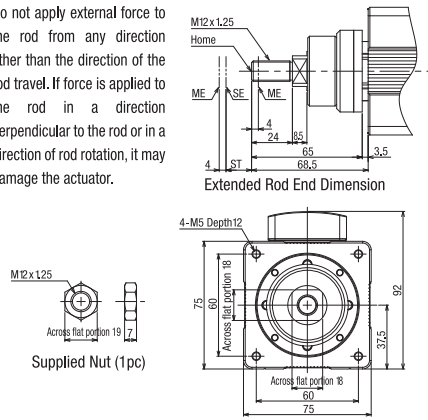

### Brake Option

\*The ROBO Cylinder with the optional brake is heavier by 0.3kg.

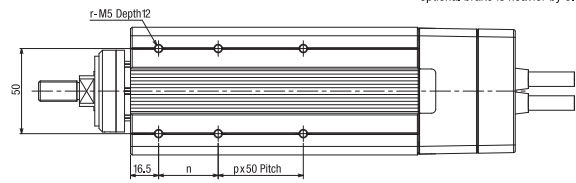

Stroke	L			m			n	p	r	Weight (kg)		
	60W	100W	150W	60W	100W	150W				60W	100W	150W
50	126	133	145	69	76	88	25	0	4	2.4	2.6	2.9
100	176	176	176	119	119	119	35	0	4	2.9	3.1	3.3
150	226	226	226	169	169	169	35	1	6	3.5	3.7	3.9
200	276	276	276	219	219	219	35	2	8	4.1	4.2	4.4
250	326	326	326	269	269	269	35	3	10	4.6	4.8	5.0
300	376	376	376	319	319	319	35	4	12	5.2	5.4	5.6

## Outline Drawings of Single Guide Type

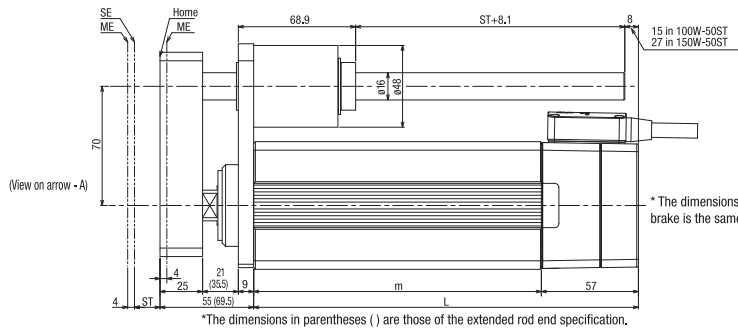
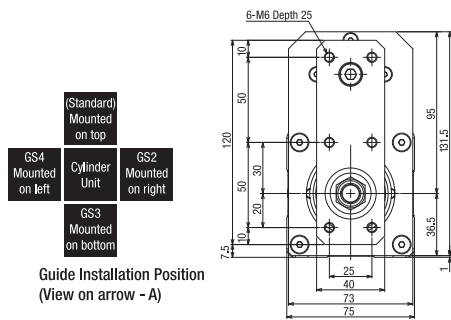

Stroke	L			m			n	p	r	Weight (kg)		
	60W	100W	150W	60W	100W	150W				60W	100W	150W
50	126	133	145	69	76	88	25	0	4	3.5	3.7	4.0
100	176	176	176	119	119	119	35	0	4	4.1	4.3	4.5
150	226	226	226	169	169	169	35	1	6	4.8	4.9	5.1
200	276	276	276	219	219	219	35	2	8	5.4	5.6	5.8
250	326	326	326	269	269	269	35	3	10	6.1	6.2	6.4
300	376	376	376	319	319	319	35	4	12	6.7	6.9	7.1

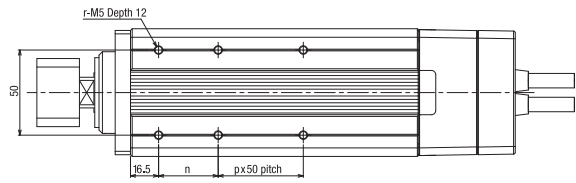



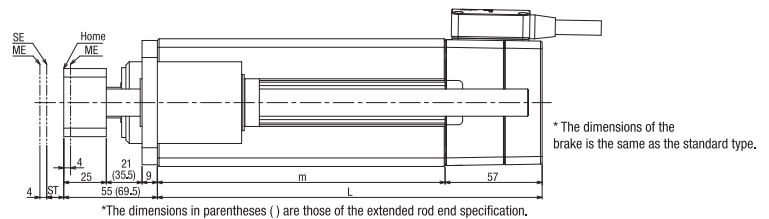
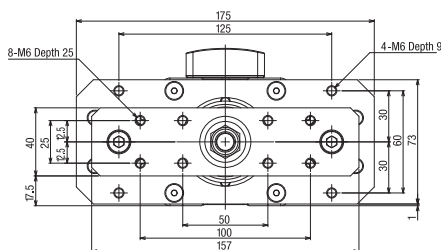

## Outline Drawings of Double Guide Type

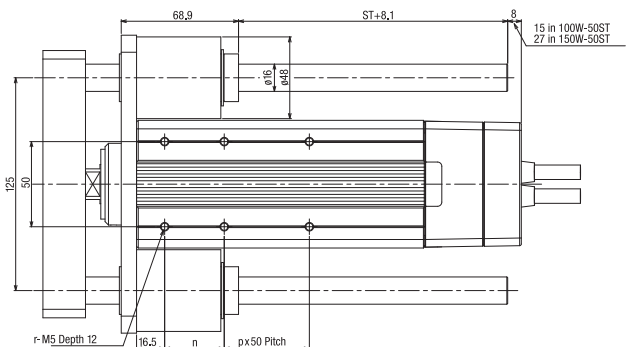

Stroke	L			m			n	p	r	Weight (kg)		
	60W	100W	150W	60W	100W	150W				60W	100W	150W
50	126	133	145	69	76	88	25	0	4	4.3	4.5	4.8
100	176	176	176	119	119	119	35	0	4	5.0	5.1	5.3
150	226	226	226	169	169	169	35	1	6	5.7	5.9	6.1
200	276	276	276	219	219	219	35	2	8	6.4	6.6	6.8
250	326	326	326	269	269	269	35	3	10	7.2	7.3	7.5
300	376	376	376	319	319	319	35	4	12	7.9	8.0	8.2



# Controller

	Controller Series / Type	SCON	SSEL	XSEL		
				P Standard Type	Q Global Type	
Basic Specifications	Image					
	Power-supply Capacity	Max. 844VA	Max. 1660VA (400W and two-axis operation)	Max. 4988VA (Six-axis operation with a total of 2400W)		
	Input Power Supply	Single-phase AC200V	Single-phase 100 VAC Single-phase 100 VAC	Three-phase 200 VAC Single-phase 200 VAC		
	Operating Power Supply Voltage Range	±10%				
Control Specifications	Total Output with Max. Axes Connected (W)	750W (200V Power Supply Specification)	400W (100V Power Supply Spec) 800W (200V Power Supply Spec)	2400W (Three-phase) 1600W (Single-phase)		
	Max. Number of Controlled Axes	1 axis	2 axis	6 axis		
	Position Detection Method	Incremental Encoder / Absolute Encoder				
	Safety Circuit Configuration	Redundant Circuits Cannot be Provided		Redundant Circuits Cannot be Provided	Redundant Circuits Can be Provided	
	Operation Method	Positioner Operation Pulse Train Control	Program Operation Positioner Operation (Selectable)	Program Operation Only		
Programs	Number of Programs	-	-	128		
	Number of Program Steps	-	-	9999		
	Number of Multi-task Programs	-	8	16		
	Number of Positions	512 max.	20000			
	Data Input Device (Optional)	Teaching Pendant Models: CON-T/RCM-E  PC Software Models: RCM-101-MW (For RS232 communication) RCM-101-USB (For USB communication)	Teaching Pendant Models: SEL-T-J/SEL-TD-J  PC Software Models: IA-101-X-MW-J (For RS232 communications) IA-101-X-USB (For USB communications)	Teaching Pendant Models: SEL-T/SEL-TD  PC Software Models: IA-101-X-MW (For RS232 communications) IA-101-X-USBMW (For USB communications)	Teaching Pendant Model: SEL-TD  PC Software Model: IA-101-XA-MW (With the RS232 communication cable meeting the safety category requirements)	
Input/Output Communication	Standard I/O	16 input points/16 output points (NPN or PNP can be selected)	24 input points/8 output points (NPN or PNP can be selected)	32 input points/16 output points (NPN or PNP can be selected)		
	Extended I/O	Not Allowed		192 maximum input points/192 maximum output points		
	Field Network	DeviceNet / CC-Link / ProfiBus	(To be supported in the future)	DeviceNet / CC-Link / ProfiBus		
General Specifications	Ambient Air Temp/Humidity	0~40°C, 10 to 95% RH (non-condensing)				
	Surrounding Environment	There should be no corrosive gases. In particular, there should not be high levels of dust.				
	External Dimensions	72 (W) × 200.5 (H) × 121 (D)	100 (W) × 202.6 (H) × 126 (D) When an absolute battery is installed	340 (W) × 195 (H) × 125.3 (D) (6-axis, absolute specification)		
	Weight	1.1kg	1.4kg	5.7kg (6-axis, absolute specification)		
	Accessories	Flat I/O Cable (40-core)	Flat I/O Cable (34-core)	Flat I/O Cable (50-core)		

**IAI America, Inc.**

Headquarters: 2690 W. 237th Street Torrance, CA 90505  
 Chicago Office: 1261 Hamilton Parkway Itasca, IL 60143  
 Atlanta Office: 1220 Kennestone Circle Suite E, Marietta, GA 30066

**IAI (Shanghai) Co., Ltd.**

SHANGHAI JIAHUA BUSINESS CENTER A8404.808  
 Hongqiao Rd. Shanghai 200030, China

**IAI Industrieroboter GmbH**

Ober der Röth 4, D-65824 Schwalbach am Taunus, Germany

Website: [www.intelligentactuator.com](http://www.intelligentactuator.com)

Due to product improvements, the information presented in this catalog is subject to change without notice

