

Controller for RCP2
High-Output Motor

PCON-CF

**RCP2 series high-thrust,
high-speed, waterproof
dedicated controllers**

Model **PCON-CF**



- 1** This model is a positioner type that can easily execute up to 512 positioning points.
- 2** The I/O signal pin assignments can be changed for each function, from an available 6 or more pin patterns.
- 3** It can be operated using the same signal as an electromagnetic valve that operates an air cylinder, and can be used as its replacement.
- 4** Its compact size allows users to conserve space around the control panel.
(35 mm wide x 68.1 mm deep x 178.5 mm high)

(Connecting Actuators)



ROBO Cylinder High-Thrust Type
RCP2-RA10C



ROBO Cylinder High-Speed Type
RCP2-HS8C / HS8R



ROBO Cylinder Waterproof Type
RCP2W-SA16C

Model

PCON Series	—	CF Name	—	86P Motor Type	—		—	□	—	□	—	0 Voltage: 24 V
								Standard I/O		I/O cable length		
								NP: NPN specifications (standard) PN: PNP specifications		0: No cable 2: 2m		3: 3m 5: 5m

System configuration

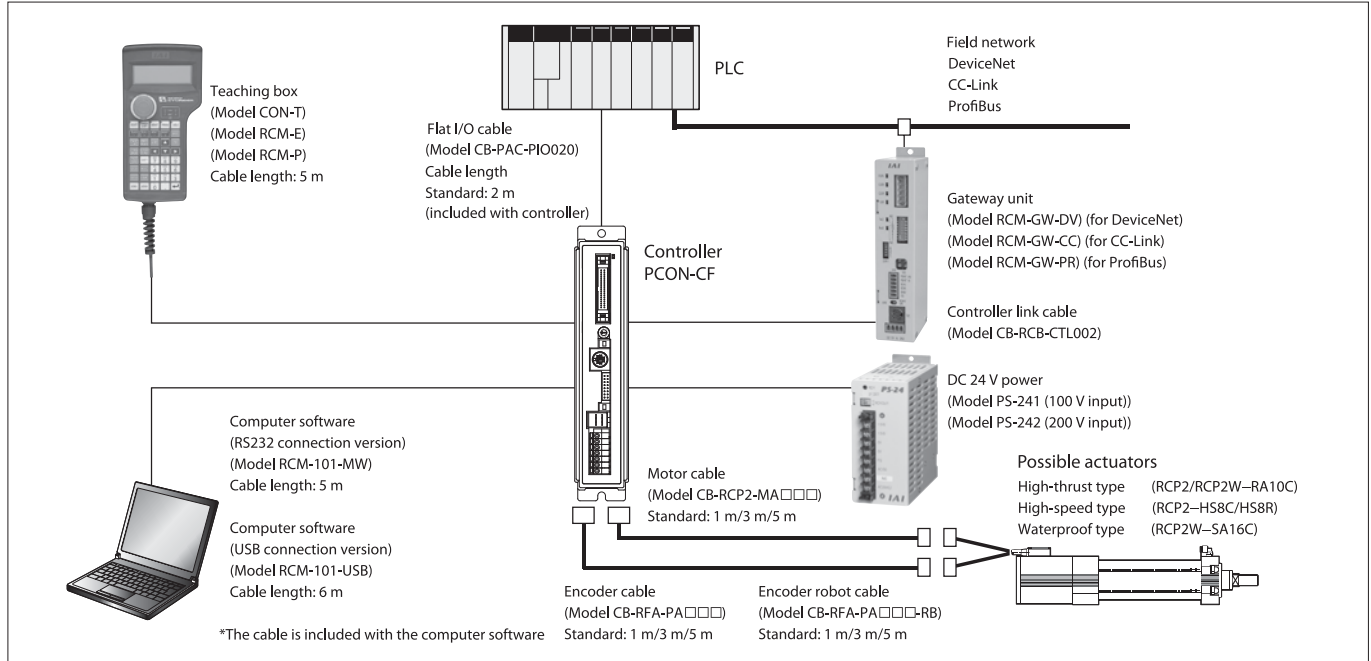

Specifications

Component	Specifications
Connecting actuator	RCP2/RCP2W-RA10C RCP2-HS8C/HS8R RCP2W-SA16C
No. of control axes:	1
Operating system	positioner
No. of positioning points:	512
Back-up memory:	EEPROM
I/O connector:	40-pin connector
I/O points (*1)	Input: 16 points. Output: 16 points
Serial communication:	RS485, 1 ch.
Peripheral device communication cable:	CB-PAC-PIO□□□
Incremental encoder	with position detection system
Built-in drive source	shut-off relay for emergency stopping
Electromagnetic brake	forced release switch ON/OFF
Motor cable	CB-RCP2-MA□□□
Encoder cable (Encoder robot cable)	CB-RFA-PA□□□ (CB-RFA-PA-□□□-RB)
Input power:	DC 24 V ±10%
Maximum power capacity:	6 A (Surge current= motor drive source power only, peak 10 A)
Dielectric strength:	DC 500 V, 1 MΩ
Ambient operating temperature:	0-40°C (about 20°C is desirable)
Ambient operating humidity for use:	95% RH or less (no condensation)
Ambient operating environment:	No corrosive gases, no dust
Protection class:	IP20
Mass:	Approximately 320 g

(*1) The I/O pin assignments are the same as other PCON controllers.

External View & Dimensions

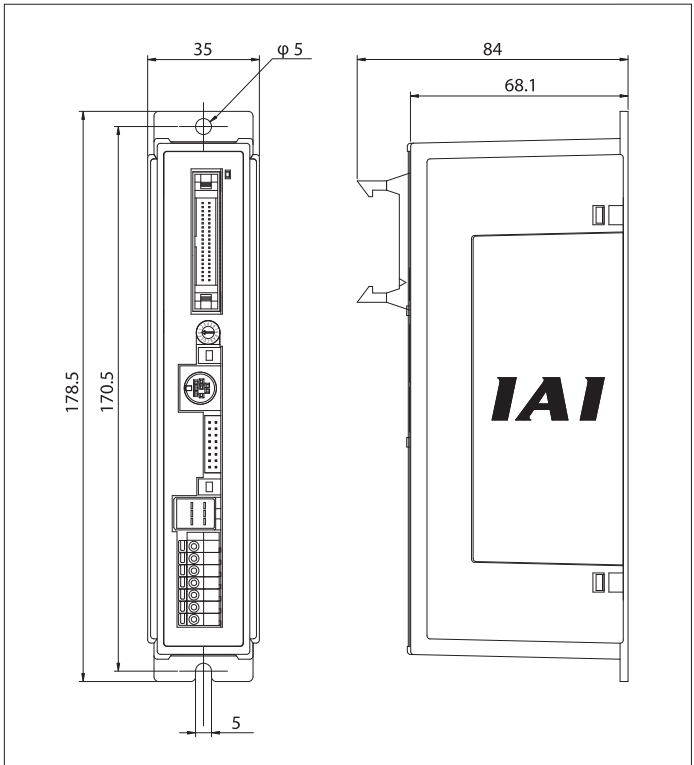

IAI America, Inc.

Headquarters: 2690 W. 237th Street Torrance, CA 90505 (800) 736-1712
Chicago Office: 1261 Hamilton Parkway Itasca, IL 60143 (800) 944-0333
Atlanta Office: 1220 Kennestone Circle, Suite E Marietta, GA 30066 (888) 354-9470

IAI Industrieroboter GmbH

IAI (Shanghai) co., Ltd.

www.intelligentactuator.com



Subject matter in this catalog may change without notice due to product improvements.