

# RCA2-TFA4NA

Robo Cylinder, Mini Table Type, Short-Length Flat Type, Actuator Width 71 mm, 24V Servo Motor, Ball Screw Specification/Lead Screw Specification

Model Specification Items	<b>RCA2</b> — <b>TFA4NA</b> — <b>I</b> — <b>20</b> — <input type="checkbox"/> — <input type="checkbox"/> — <input type="checkbox"/> — <input type="checkbox"/> — <input type="checkbox"/>	Series — Type — Encoder type — Motor type — Lead — Stroke — Applicable controller — Cable length — Options
	I: Incremental 20:20W Servo motor * The Simple absolute encoder is also considered type "I". 6: Ball screw 6mm 30: 30mm 4: Ball screw 4mm 50: 50mm 2: Ball screw 2mm 6S: Lead screw 6mm 4S: Lead screw 4mm 2S: Lead screw 2mm	A1: ACON N: None ASEL P: 1m A3: AMEC S: 3m ASEP M: 5m MSEP X <input type="checkbox"/> : Custom Length See options below.

\* See page Pre-47 for details on the model descriptions.



Power-saving

Technical References Appendix P.5



- (1) The payload is the value when the actuator is operated at an acceleration of 0.3 G (0.2G for 2mm-lead, if used vertically and for lead screw specification). The acceleration limit is the value indicated above.
- (2) If the actuator is used vertically, pay attention to rod contact because the rod will come down when the power is turned off.
- (3) See page A-71 for details on push motion.

## Actuator Specifications

### Leads and Payloads

Model number	Motor output (W)	Feed screw	Lead (mm)	Max. Load Capacity		Rated thrust (N)	Positioning Repeatability (mm)	Stroke (mm)
				Horizontal (kg)	Vertical (kg)			
RCA2-TFA4NA-I-20-6-①-②-③-④	20	Ball screw	6	2	0.5	33.8	±0.02	30 50
RCA2-TFA4NA-I-20-4-①-②-③-④			4	3	0.75	50.7		
RCA2-TFA4NA-I-20-2-①-②-③-④			2	6	1.5	101.5		
RCA2-TFA4NA-I-20-6S-①-②-③-④	20	Lead screw	6	0.25	0.125	19.9	±0.05	30 50
RCA2-TFA4NA-I-20-4S-①-②-③-④			4	0.5	0.25	29.8		
RCA2-TFA4NA-I-20-2S-①-②-③-④			2	1	0.5	59.7		

### Stroke and Maximum Speed

Lead	Stroke	30 (mm)		50 (mm)	
		Ball screw	Lead screw	Ball screw	Lead screw
Ball screw	6	270<220>		300	
	4	200			
	2	100			
Lead screw	6	220		300	
	4	200			
	2	100			

Code explanation ① Stroke ② Applicable controller ③ Cable length ④ Options \*See page A-71 for details on push motion. \*The values enclosed in < > apply to vertical settings. (Unit: mm/s)

### ① Stroke

Stroke (mm)	Standard price	
	Feed screw	
	Ball screw	Lead screw
30	—	—
50	—	—

### ③ Cable Length

Type	Cable symbol	Standard price
Standard (Robot Cables)	P (1m)	—
	S (3m)	—
	M (5m)	—
Special length	X06 (6m) ~ X10 (10m)	—
	X11 (11m) ~ X15 (15m)	—
	X16 (16m) ~ X20 (20m)	—

\* The standard cable for the RCA2 is the robot cable.

\* See page A-59 for cables for maintenance.

### ④ Options

Name	Option code	See page	Standard price
Brake	B	→ A-42	—
Connector cable exits from the left	K1	→ A-51	—
Connector cable exits from the front	K2	→ A-51	—
Connector cable exits from the right	K3	→ A-51	—
Power-saving specification	LA	→ A-52	—

### Actuator Specifications

Item	Description
Drive System	Ball screw/Lead screw, ø6mm, rolled C10
Lost Motion	Ball screw: 0.1mm or less Lead screw: 0.3mm or less (initial value)
Frame	Material: Aluminum, white alumite treated
Allowable dynamic moment (Note)	Ma: 9.9 N·m, Mb: 9.9 N·m, Mc: 3.3 N·m
Allowable static moment	Ma: 14.1 N·m, Mb: 14.1 N·m, Mc: 6.7 N·m
Ambient operating temperature, humidity	0 to 40°C, 85% RH or less (Non-condensing)
Service life	Lead screw specification
	Ball screw specification
	Horizontal specification: 10 million cycles, Vertical specification: 5 million cycles
	5,000km or 50 million cycles

(Note) For cases when the guide service life has been set to 5,000km.

Dimensional Drawings

CAD drawings can be downloaded from the website. [www.intelligentactuator.com](http://www.intelligentactuator.com)



- (\*1) Connect the motor-encoder integrated cable here. See page A-59 for details on cables.
- (\*2) After homing, the slider moves to the ME, therefore, please watch for any interference with surrounding objects.

For Special Orders Appendix P.15

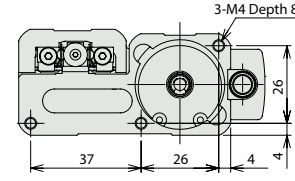
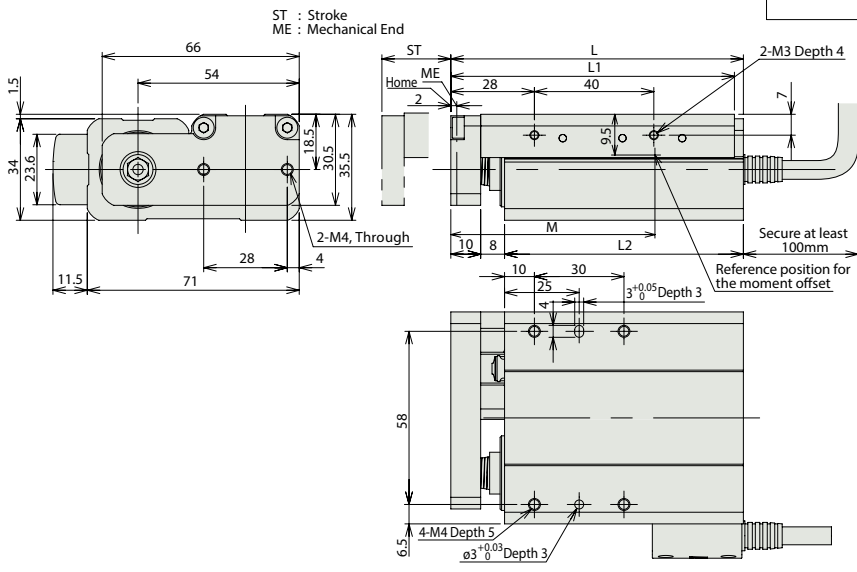
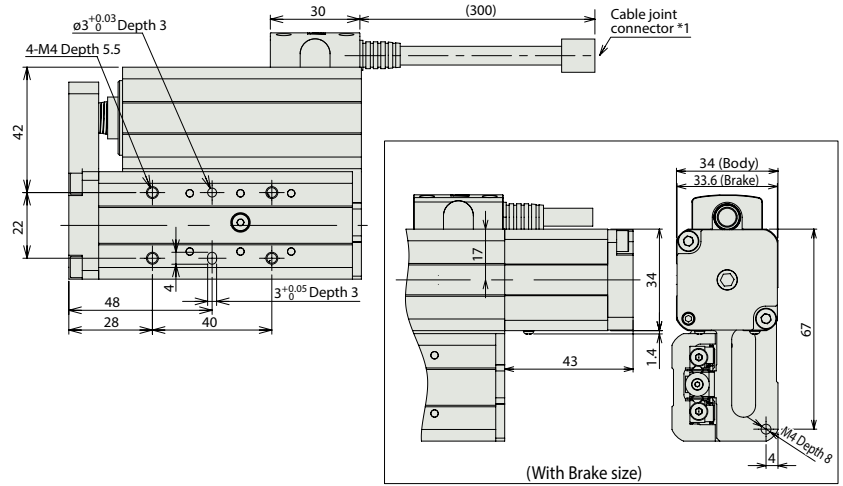
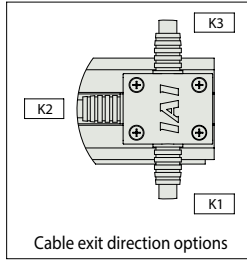

\* Brake-equipped models are heavier by 0.15kg.

**■ Dimensions and Weight by Stroke**

Stroke	30	50
L	98	118
L1	95	115
L2	80	100
M	66	86
Weight (kg)	0.6	0.72

Applicable Controllers

RCA2 series actuators can be operated with the controllers indicated below. Select the type according to your intended application. \* ACON-CY also can be used.

Name	External view	Model number	Features	Maximum number of positioning points	Input power	Power-supply capacity	Standard price	Reference page
Solenoid Valve Type		AMEC-C-20I①-②-2-1	Easy-to-use controller, even for beginners	3 points	AC100V	2.4A rated	—	→ P537
		ASEP-C-20I①-②-2-0	Simple controller operable with the same signal as a solenoid valve					→ P547
Solenoid valve multi-axis type PIO specification		MSEP-C-③-④-⑤-⑥-⑦-⑧-2-0	Positioner type based on PIO control, allowing up to 8 axes to be connected	256 points	DC24V	(Standard) 1.3A rated 4.4A max. (Power-saving) 1.3A rated 2.5A max.	—	→ P563
Solenoid valve multi-axis type Network specification		MSEP-C-③-④-⑤-⑥-⑦-⑧-0-0	Field network-ready positioner type, allowing up to 8 axes to be connected					
Positioner type		ACON-C-20I①-②-2-0	Positioning is possible for up to 512 points	512 points	DC24V	(Standard) 1.3A rated 4.4A max. (Power-saving) 1.3A rated 2.5A max.	—	→ P631
Safety-Compliant Positioner Type		ACON-CG-20I①-②-2-0						
Pulse Train Input Type (Differential Line Driver)		ACON-PL-20I①-②-2-0	Pulse train input type with differential line driver support	(—)	DC24V	(Standard) 1.3A rated 4.4A max. (Power-saving) 1.3A rated 2.5A max.	—	→ P631
Pulse Train Input Type (Open Collector)		ACON-PO-20I①-②-2-0	Pulse train input type with open collector support					
Serial Communication Type		ACON-SE-20I①-N-0-0	Dedicated Serial Communication	64 points	DC24V	(Standard) 1.3A rated 4.4A max. (Power-saving) 1.3A rated 2.5A max.	—	→ P631
Program Control Type		ASEL-CS-1-20I①-②-2-0	Programmed operation is possible. Can operate up to 2 axes	1,500 points	DC24V	(Standard) 1.3A rated 4.4A max. (Power-saving) 1.3A rated 2.5A max.	—	→ P675

\* This is for the single-axis ASEL. \* Enter the code "LA" in ① when the power-saving specification is specified. \* ① indicates I/O type (NP/PN). \* ③ indicates number of axes (1 to 8). \* ④ indicates field network specification symbol.

- Slider Type
- Mini
- Standard
- Controllers Integrated
- Rod Type
- Mini
- Standard
- Controllers Integrated
- Table/ Arm/ Flat Type
- Mini
- Standard
- Gripper/ Rotary Type
- Linear Servo Type
- Clean-room Type
- Splash-Proof Type
- Pulse Motor
- Servo Motor (24V)
- Servo Motor (200V)
- Linear Servo Motor