

# ERC3-SA5C

Controller-Integrated, Slider Type, Actuator Width 50mm, Pulse Motor, Straight Type

Model Specification Items	<b>ERC3 - SA5C - I - 42P</b>									
Series	Type	Encoder type	Motor type	Lead	Stroke	I/O type	Cable length	Controller type	Options	
		I: Incremental	42□ Pulse motor	20:20mm 12:12mm 6: 6mm 3: 3mm	50:50mm ? 800:800mm (50mm pitch increments)	NP: PIO (NPN) type PN: PIO (PNP) type SE: SIO type PLN: Pulse-train (NPN) type PLP: Pulse-train (PNP) type	N: None P: 1m S: 3 m M: 5m X□□: Custom length	CN: CON type MC: MEC type	B : Brake NM : Non-motor end specification ABU: Simple absolute specification	

\* See page Pre-47 for details on the model descriptions.



Technical References Appendix P.5



- (1) If the high-output setting is enabled (factory default), the duty must be limited. (Refer to page A-95.) If the high-output setting is disabled, the payload and maximum speed become lower, but the actuator can be used at a duty of 100%. Refer to the operation manual for information on how to change the high-output setting.
- (2) Refer to page A-99 for the payload at each speed/acceleration when the high-output setting is enabled.

### Speed vs. Load Capacity

Due to the characteristics of the pulse motor, the ERC3 series' load capacity decreases at high speeds. In the table below, check if your desired speed and load capacity are supported.

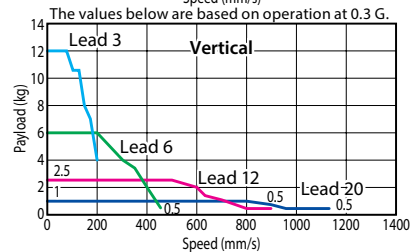
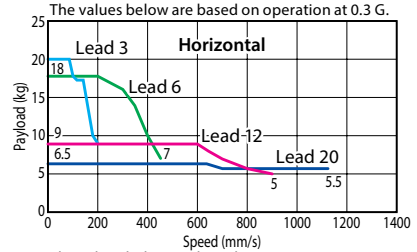

High-output setting enabled (Factory default)

### Actuator Specifications (High-output Setting Enabled)

#### Leads and Payloads (Note 1) Take caution that the maximum payload decreases as the speed increases.

Model number	Lead (mm)	Max. Load Capacity (Note 1)		Stroke (mm)
		Horizontal (kg)	Vertical (kg)	
ERC3-SA5C-I-42P-20-①-②-③-④	20	6.5	1	50~800 (every 50mm)
ERC3-SA5C-I-42P-12-①-②-③-④	12	9	2.5	
ERC3-SA5C-I-42P-6-①-②-③-④	6	18	6	
ERC3-SA5C-I-42P-3-①-②-③-④	3	20	12	

Code explanation ① Stroke ② I/O type ③ Cable length ④ Options \*See page A-71 for details on push motion.

#### Stroke and Maximum Speed (Unit: mm/s)

Stroke Lead	50~450 (every 50mm)	500 (mm)	550 (mm)	600 (mm)	650 (mm)	700 (mm)	750 (mm)	800 (mm)
20	1120	1115	935	795	680	585	510	
12	900	805	665	560	475	405	350	300
6	450	400	330	280	235	200	175	150
3	225	200	165	140	115	200	85	75

\*The values of lead 3 apply when acceleration is at 0.1G.

#### ① Stroke

① Stroke (mm)	Standard price	① Stroke (mm)	Standard price
50	—	450	—
100	—	500	—
150	—	550	—
200	—	600	—
250	—	650	—
300	—	700	—
350	—	750	—
400	—	800	—

#### ③ Cable Length

Type	Cable symbol	Standard price
Standard (Robot Cables)	P (1m)	—
	S (3m)	—
	M (5m)	—
Special length	X06 (6m) ~ X10 (10m)	—

\* See page 586 for cables for maintenance.

#### ④ Options

Name	Option code	See page	Standard price
Brake	B	→ A-42	—
Non-motor end specification	NM	→ A-52	—
Simple absolute specification	ABU	→ A-42	— (*)

(\*) If the simple absolute specification is selected, SE (SIO type) I/O type and the separately sold PIO converter with simple absolute specification (with battery) are required.

### Actuator Specifications

Item	Description
Drive System	Ball screw, ø10mm, rolled C10
Positioning repeatability (*1)	±0.02mm [±0.03mm]
Lost Motion	0.1mm or less
Allowable static moment	Ma: 29.4 N·m, Mb: 42.0 N·m, Mc: 60.5 N·m
Allowable dynamic moment (*2)	Ma: 7.1 N·m, Mb: 10.2 N·m, Mc: 14.7 N·m
Allowable overhang	150mm or less in Ma, Mb and Mc directions
Ambient operating temperature, humidity	0 to 40°C, 85% RH or less (Non-condensing)

(\*1) The specification in [ ] applies when the lead is 20mm.

(\*2) Based on 5,000km of traveling life.

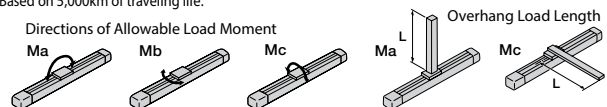

Dimensional Drawings

CAD drawings can be downloaded from the website. [www.intelligentactuator.com](http://www.intelligentactuator.com)

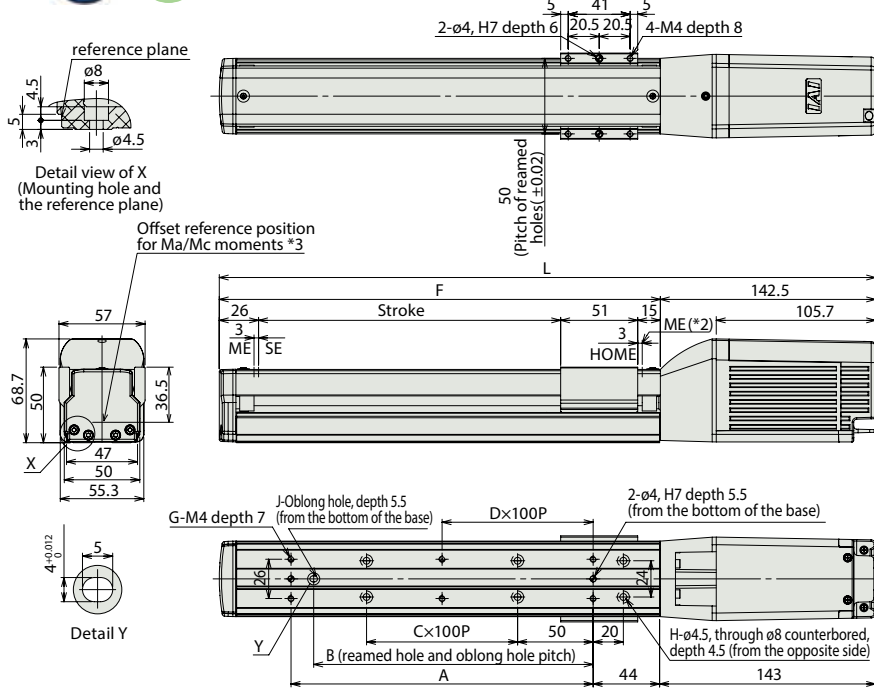

\*1 Connect the power & I/O cable. Refer to page 586 for details on this cable SE: Stroke End ME: Mechanical End

\*2 The slider moves to the ME during home return, so pay attention to possible contact with surrounding structures.

\*3 Reference position is used when calculating the Ma and Mc moments.

■ Dimensions and Mass by Stroke

Stroke	50	100	150	200	250	300	350	400	450	500	550	600	650	700	750	800
L	284.5	334.5	384.5	434.5	484.5	534.5	584.5	634.5	684.5	734.5	784.5	834.5	884.5	934.5	984.5	1034.5
A	73	100	100	200	200	300	300	400	400	500	500	600	600	700	700	800
B	0	85	85	185	185	285	285	385	385	485	485	585	585	685	685	785
C	0	0	1	1	2	2	3	3	4	4	5	5	6	6	7	7
D	0	0	0	1	1	2	2	3	3	4	4	5	5	6	6	7
F	142	192	242	292	342	392	442	492	542	592	642	692	742	792	842	892
G	4	4	4	6	6	8	8	10	10	12	12	14	14	16	16	18
H	4	4	6	6	8	8	10	10	12	12	14	14	16	16	18	18
J	0	1	1	1	1	1	1	1	1	1	1	1	1	1	1	1
Weight (kg)	1.4	1.5	1.6	1.7	1.9	2.0	2.1	2.2	2.3	2.4	2.5	2.7	2.8	2.9	3.0	3.1

Controllers (Built into the Actuator)

②I/O type

With the ERC3 series, one of the following five types of built-in controllers can be selected depending on the external input/output (I/O) type. Select the type that meets your purpose.

Name	External view	Model number	Features	Maximum number of positioning points	Input power	Power supply capacity	Standard price	Reference page
PIO type (NPN specification)		ERC3-SA5C-I-42P-□-□-NP-□-□	Simple control type accommodating up to 16 positioning points	16	DC24V	High-output setting enabled: 3.5A rated 4.2A max. High-output setting disabled: 2.2A	—	→ P577
PIO type (PNP specification)		ERC3-SA5C-I-42P-□-□-PN-□-□	I/O type supporting inputs/outputs of the PNP specification often used overseas	16				
SIO type		ERC3-SA5C-I-42P-□-□-SE-□-□	High-function type accommodating up to 512 positioning points (PIO converter is used)	512				
Pulse-train type (NPN specification)		ERC3-SA5C-I-42P-□-□-PLN-□-□	Pulse-train input type supporting the NPN specification	—				
Pulse-train type (PNP specification)		ERC3-SA5C-I-42P-□-□-PLP-□-□	Pulse-train input type supporting the PNP specification	—				