

EC-R7

Rod Type Motor Unit Type Coupled Motor Body Width **73 mm** **24v Stepper Motor**

Model Specification Items

EC — R7
Series — Type

Lead

S : 24mm
H : 16mm
M : 8mm
L : 4mm

Stroke

50: 50mm
300: 300mm
(Every 50mm)

Cable Length

0: With terminal block type connector
1: 1m
10: 10m

Options

Refer to Options below.

* Please refer to P.16 for more information about the model specification items.

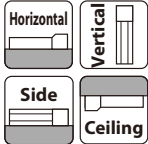

* Depending on the model, there may be some limitations to using the vertical, side, and ceiling mount positions. Please contact IAI for more information regarding mounting positions.



Table of Payload by Speed/Acceleration

Lead 24

Orientation	Acceleration (G)					
	Horizontal		Vertical			
Speed (mm/s)	0.3	0.5	0.7	1	0.3	0.5
0	20	18	15	12	3	3
200	20	18	15	12	3	3
400	20	14	12	8	3	3
420	17	12	10	6	3	3
600	14	6	5	4	3	2
640	5	3	2	1.5	2	1
800	5	1	1			
860	2	0.5				

Lead 16

Orientation	Acceleration (G)					
	Horizontal		Vertical			
Speed (mm/s)	0.3	0.5	0.7	1	0.3	0.5
0	50	40	35	30	8	8
140	50	40	35	30	8	8
280	50	35	25	20	7	7
420	25	18	14	10	4.5	4
560	10	5	3	2	2	1
700	2					

Lead 8

Orientation	Acceleration (G)					
	Horizontal		Vertical			
Speed (mm/s)	0.3	0.5	0.7	1	0.3	0.5
0	60	50	45	40	18	18
70	60	50	45	40	18	18
140	60	50	45	40	16	12
210	60	40	31	26	10	9
280	34	20	15	11	5	4
350	12	4	1		2	1

Lead 4

Orientation	Acceleration (G)					
	Horizontal		Vertical			
Speed (mm/s)	0.3	0.5	0.7	1	0.3	0.5
0	80	70	65	60	19	19
35	80	70	65	60	19	19
70	80	70	65	60	19	19
105	80	60	50	40	18	18
140	50	30	20	15	12	10
175	15				2	



- (1) The maximum acceleration/deceleration is 1G for horizontal, and 0.5G for vertical use.
- (2) The actuator specifications display the payload's maximum value, but it will vary depending on the acceleration and speed. Please refer to "Table of Payload by Speed/Acceleration" at right for more details.
- (3) The value of the horizontal payload assumes that there is an external guide. Please be aware that the anti-rotation stopper can be damaged when an external force is applied to the rod from any direction other than the moving direction.
- (4) When performing push operation, refer to P.65.
- (5) Depending on the ambient operating temperature, duty control is necessary. Please refer to P.67 for more information.
- (6) The power capacity can be reduced according to the setting. Please refer to P.63 for the relevant "Table of Payload by Speed/Acceleration."

Actuator Specifications

Lead and Payload

Model	Lead (mm)	Max. payload		Max. push force (N)*
		Horizontal (kg)	Vertical (kg)	
EC-R7S-①-②-③	24	20	3	182
EC-R7H-①-②-③	16	50	8	273
EC-R7M-①-②-③	8	60	18	547
EC-R7L-①-②-③	4	80	19	1094

Legend: ① Stroke ② Cable Length ③ Option

Stroke and Max. Speed

(Unit: mm/s)

Lead (mm)	50~300 (Every 50mm)
24	860 <640>
16	700 <560>
8	350
4	175

<> represents vertical operation.

*Speed limitation applies to push motion. See the manual or contact IAI.

① Stroke

① Stroke (mm)	EC-R7	① Stroke (mm)	EC-R7
50	○	200	○
100	○	250	○
150	○	300	○

② Cable Length

Cable code	Cable length
0	No cable (with connector)
1 to 3	1 to 3m
4 to 5	4 to 5m
6 to 10	6 to 10m

② Options

Type	Option code	Reference page
Brake	B	See P.59
Flange (front)	FL	See P.59
Foot bracket	FT	See P.60
Tip adapter (Internal thread)	NFA	See P.61
Non-motor end specification	NM	See P.62
PNP specification	PN	See P.62
Battery-less Absolute Encoder specification	WA	See P.62
Wireless communication specification	WL	See P.62

Actuator Specifications

Item	Description
Drive system	Ball screw ø12mm, rolled C10
Positioning repeatability	±0.05mm
Rod	ø30mm Material: Aluminum, hard alumite treatment
Static allowable torque on rod tip	0.5N·m
Rod tip maximum angular displacement (*)	±1.5 degrees
Ambient operating temperature/humidity	0 to 40°C, 85% RH or less (Non-condensing)

(*) The rod tip angular displacement (initial value for reference) when the rod tip static allowable torque is applied with the rod fully retracted.

Dimensions

CAD drawings can be downloaded from our website.
www.intelligentactuator.com



*1 When the rod is returning to its home position, please be careful of interference from surrounding objects, as it will travel until it reaches the M.E.
M.E: Mechanical end S.E: Stroke end
*2 The direction of width across flats varies depending on the product. Those flats cannot be used for reference plane.

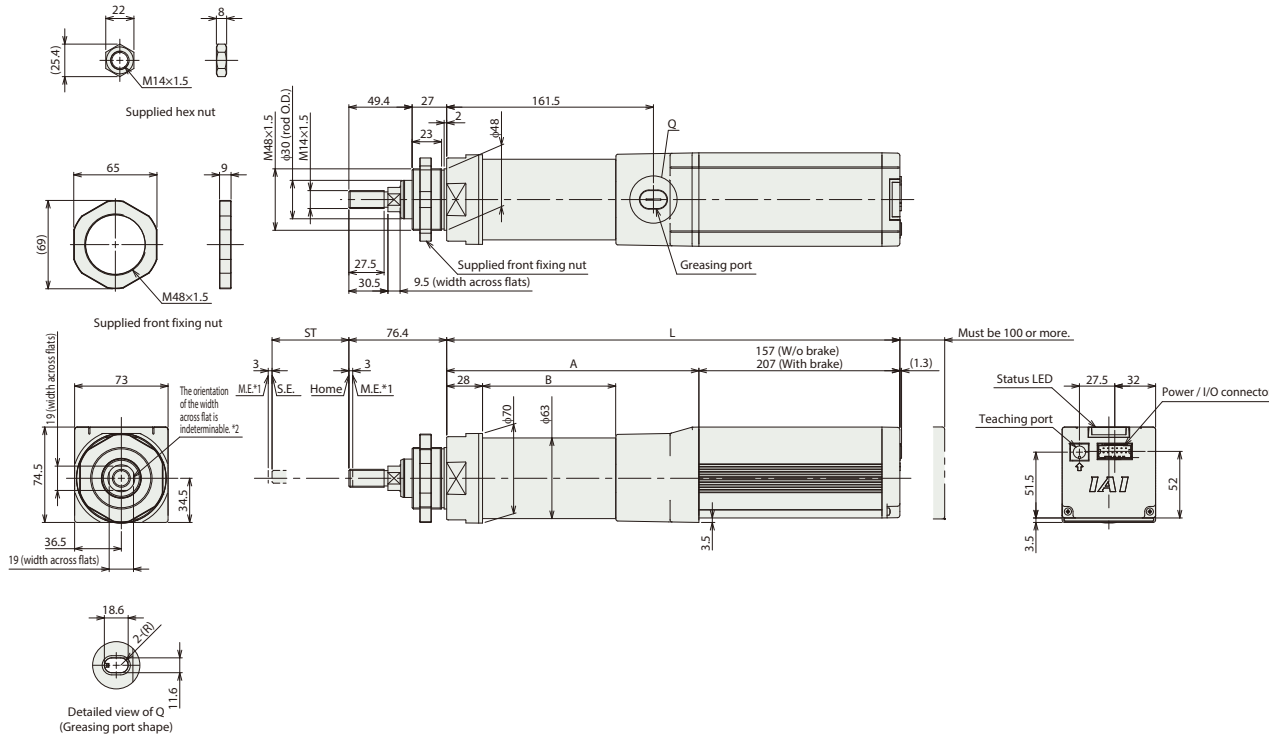

■ Dimensions and Mass by Stroke

Stroke	50	100	150	200	250	300	
L	W/o Brake	354	404	454	504	554	604
	With Brake	404	454	504	554	604	654
A	197	247	297	347	397	447	
B	104	154	204	254	304	354	
Weight (kg)	W/o Brake	3.3	3.5	3.7	3.9	4.1	4.3
	With Brake	3.5	3.7	3.9	4.1	4.3	4.5

Controller side Options/Accessories

Name	Touch Panel Teaching Pendant	PC software	24VDC power supply
External view			
Model	<input type="checkbox"/> TB-02 (for wired connection only) <input type="checkbox"/> TB-03 (for wired/wireless connection)	<input type="checkbox"/> RCM-101-MW (RS232 connection version) <input type="checkbox"/> RCM-101-USB (USB connection version)	<input type="checkbox"/> PS-241 (100V input) <input type="checkbox"/> PS-242 (200V input)
Overview	<ul style="list-style-type: none"> ● TB-02 A teaching pendant equipped with functions such as start point, end point, and AVD input, trial operation, and monitoring. ● TB-03 A data setter that supports wireless connection. The start point, end point and AVD can be input with wireless connection. 	Software for start point input, end point input and AVD input, trial operation, and monitoring using a PC. Both the RS232C version and USB version are available for PC connection.	A 24VDC power supply that can instantaneously output up to 17A. Input voltage 200VAC and 100VAC specifications are available.

* For system configurations using the above tools, refer to P.68.