

PCON

■ Models C / CG / CF / CY / PL / PO / SE

Position Controllers
For RCP3/RCP2 Series

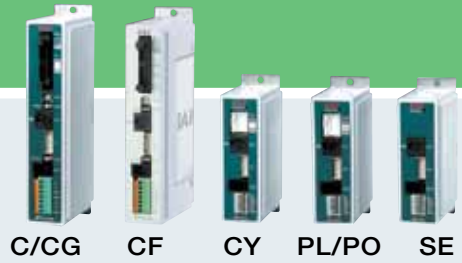

List of models

These are the position controllers that can be used with the RCP3/RCP2 Series actuators. Our line-up has 6 types, which are compatible with various control systems.

Type	C	CG	CF	CY	PL/PO	SE
Name	Positioner type	Conforming to safety category compatible type	High-thrust motor compatible type	Solenoid valve type	Pulse train control type	Serial communication type
External View						
Description	Positioner capable of a maximum of 512 points Positioning	Conforming to type C safety category specifications	Dedicated controller for RCP2 high-speed type/high-thrust type / waterproof type	Can be operated using the same control as the air cylinder type	For pulse train control	For Serial communication
Position points	512 points	512 points	512 points	3 points	—	64 points

(*1) Network connection specifications are designated by the I/O type symbols for the model.

Model

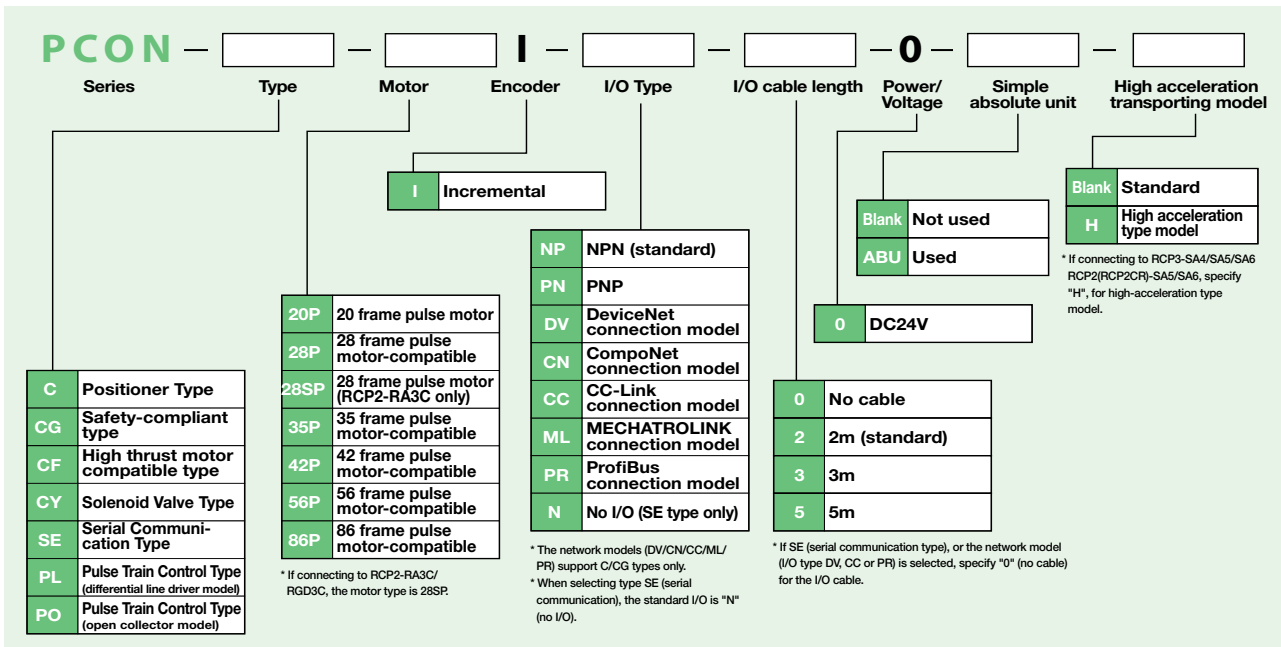

System configuration

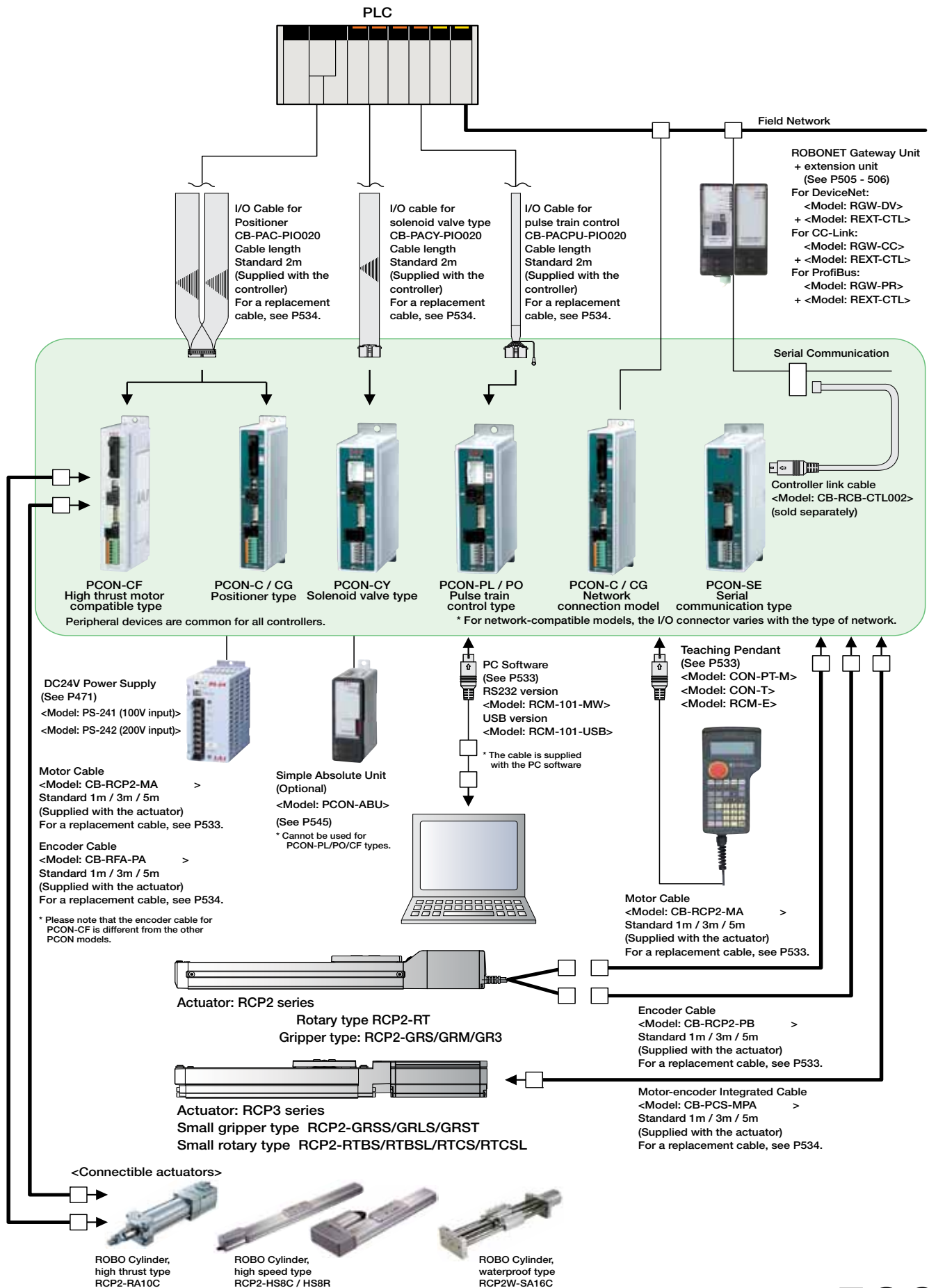

- Slider Type
- Mini
- Standard
- Controllers Integrated
- Pod Type
- Mini
- Standard
- Controllers Integrated
- Table/Arm /FlatType
- Mini
- Standard
- Gripper/ Rotary Type
- Linear Servo Type
- Cleanroom Type
- Splash-Proof
- Controllers
- PMEC /AMEC
- PSEP /ASEP
- ROBO NET
- ERC2
- PCON
- ACON
- SCON
- PSEL
- ASEL
- SSEL
- XSEL
- Pulse Motor
- Servo Motor (24V)
- Servo Motor (200V)
- Linear Servo Motor

I/O Specifications

Input section External input specifications

Item	Specifications
Input voltage	DC24V +/-10%
Input current	4mA/circuit
Leak current	1mA max./point
Isolation method	Photocoupler

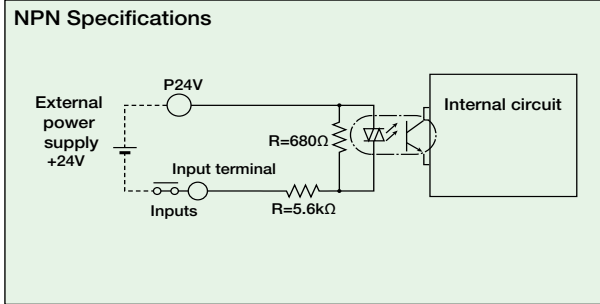

Output section External output specifications

Item	Specifications
Load Voltage	DC24V
Max. load current	50mA/point
Remaining voltage	2V or less
Isolation method	Photocoupler

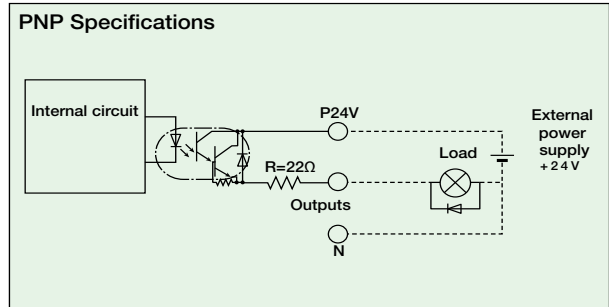
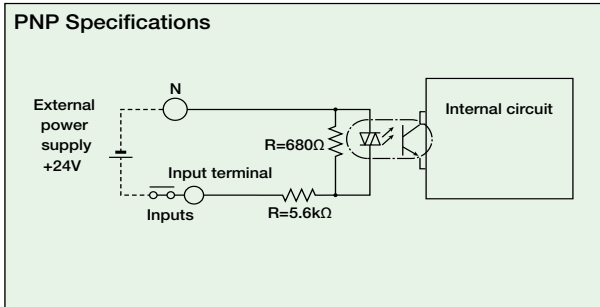
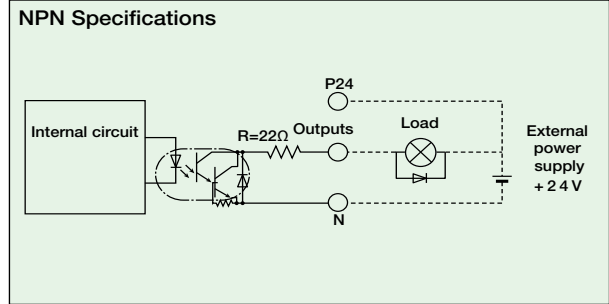

I/O Specifications

The 4 types of controllers (C/CG, CY, PL/PO, and SE) are classified by their respective I/O specifications. In addition, with the positioner type and solenoid valve type, the I/O signal details can be changed via the controller settings. As a result, a number of functions can be used.

Control Function by Type

Type	C/CG	CY	PL/PO	SE	Features
Name	Positioner type	Solenoid valve type	Pulse in-line control type	Serial communication type	
Positioner mode	○	×	×	○ (*1)	This is the basic operating mode, in which the user designates position numbers and inputs start signals.
Teaching mode	○	×	×	○ (*1)	In this mode, the slider (rod) moves based on an external signal, and the stopped positions can be registered as position data.
Solenoid valve mode	○	○	×	○ (*1)	The actuator can be moved simply by ON/OFF of position signals. This mode supports the same control signals you are already familiar with on solenoid valves of air cylinders.
Pulse train mode	×	×	○	×	In this mode, you can operate the actuator freely using pulse trains without inputting position data.
Network compatible	○ (*2)	×	×	○ (*3)	The controller can be connected to a DeviceNet or CC-Link network.

*1 Operates using network communications or serial communications.
 *2 Can make a direct connection to a field network with the network specifications.
 *3 Can be connected to a field network using a gateway unit.

Explanation of I/O Signal Functions

The table below explains the functions allocated to the controller's I/O signal. Since the signals that can be used vary depending on the controller type and settings, check the signal table for each controller to confirm the available functions.

■ Signal Function Description

Classification	Signal abbreviations	Signal	Function description
Input	CSTR	PTP strobe signal (start signal)	Input this signal to cause the actuator to start moving to the position set by the command position number signal.
	PC1 to PC256	Command position number signal	This signal is used to input a target position number (binary input).
	BKRL	Brake forced release signal	This signal forcibly releases the brake.
	RMOD	Running mode switching signal	This signal can switch the running mode when the MODE switch on the controller is set to AUTO. (AUTO when this signal is OFF, or MANU when the signal is ON)
	*STP	Pause signal	Turning this signal OFF causes the moving actuator to decelerate to a stop. The actuator will resume the remaining movement if the signal is turned ON during the pause.
	RES	Reset signal	Turning this signal ON resets the alarms that are present. If this signal is turned ON while the actuator is paused (*STP is OFF), the remaining movement can be cancelled.
	SON	Servo ON signal	The servo remains on while this signal is ON, or off while the signal is OFF.
	HOME	Home return signal	Turning this signal ON performs home-return operation.
	MODE	Teaching mode signal	Turning this signal ON switches the controller to the teaching mode. (provided that CSTR, JOG+ and JOG- are all OFF and the actuator is not moving).
	JISL	JOG/INCHING switching signal	When the main signal is off, the JOG operation will be conducted for JOG+ and JOG-. When the signal is on, the unit will do the inching operation for JOG+ and JOG-.
	JOG+, JOG-	JOG signal	When the JISL signal is off and the JOG +/- signal turns on, the unit will jog in the + (positive) direction when the JOG + turns on and the - (negative) direction when the JOG - turns on. During the JOG operation, the unit slows to a stop when the JOG +/- signal turns off.
	PWRT	Teaching signal	In the teaching mode, specify a desired position number and then turn this signal ON for at least 20ms to write the current position to the specified position number.
	ST0 to ST6	Start position command	Turning this signal ON in the solenoid valve mode causes the actuator to move to the specified position. (Start signal is not required)
TL	Torque limit selection signal	While this signal is ON, torque is limited by the value set by a parameter. The TLR signal turns on if torque has reached the specified value.	
DCLR	Deviation counter clear signal	The position deviation counter is continuously cleared while this signal is ON.	
Output	PEND/INP	In position signal	This signal turns ON when the actuator has entered the positioning band after movement. If the actuator has exceeded the positioning band, PEND does not turn OFF, but INP does. PEND and INP can be swapped within parameters.
	PM1 to PM256	Positioning complete signal	This signal is used to output the position number achieved at the completion of positioning (binary output)
	HEND	Home return completion signal	This signal turns ON upon completion of home return.
	ZONE1	Zone signal	This signal turns ON when the current actuator position has entered the range specified by the parameters.
	PZONE	Position zone signal	Turns ON when the actuator moves into a position within the range of the target position data that was set. PZONE can be used together with ZONE1, but PZONE is valid only during movement to a specified position.
	RMDS	Running mode status signal	This outputs the operation mode status.
	*ALM	Controller alarm status signal	This signal remains ON while the controller is not in the alarm condition, and turns OFF when an alarm has occurred.
	MOVE	Moving signal	Turns ON while the actuator is moving (home return), including when there is push force.
	SV	Servo ON status signal	This signal turns ON when servo is ON.
	*EMGS	Emergency stop status signal	This signal remains ON while the controller is not in the emergency stop mode, and turns OFF once an emergency stop has been actuated.
	MODES	Mode status signal	The mode signal input turns it ON when it goes into teaching mode. It turns OFF when it goes into normal mode.
	WEND	Writing complete signal	This signal remains OFF after the controller has switched to the teaching mode. It turns ON upon completion of data write using the PWRT signal. If the PWRT signal is turned Off, this signal also turns OFF.
	PE0 to PE6	Current position number signal	This signal turns ON after the controller has completed moving to the target position in the solenoid valve mode.
	TLR	Torque limiting signal	This signal turns ON once the motor torque has reached the specified value in a condition where torque is being limited by the TL signal.
	LSO to LS2	Limit switch output signal	Each signal turns ON when the current actuator position has entered the positioning band before or after the target position. If the actuator has already completed home return, these signals are output even before a movement command is issued or while the servo is OFF.
LOAD	Load output determination status signal	This signal turns ON once the motor torque has reached the specified value. (*PCON-CF dedicated signal)	
TRQS	Torque level status signal	Turns ON when the motor current reaches the threshold. (*PCON-CF dedicated signal)	

(Note) Signals with asterisks (*) are normally ON and OFF during operation.

- Slider Type
- Mini
- Standard
- Controllers Integrated
- Pod Type
- Mini
- Standard
- Controllers Integrated
- Table/Arm /FlatType
- Mini
- Standard
- Gripper/ Rotary Type
- Linear Servo Type
- Cleanroom Type
- Splash-Proof
- Controllers
- PMEC /AMEC
- PSEP /ASEP
- ROBO NET
- ERC2
- PCON
- ACON
- SCON
- PSEL
- ASEL
- SSEL
- XSEL
- Pulse Motor
- Servo Motor (24V)
- Servo Motor (200V)
- Linear Servo Motor

I/O Signal table

■ Positioner types (PCON-C / CG / CF)

Pin No.	Classification		Parameters (select PIO pattern)					
			0	1	2	3	4	5
			Positioning mode	Teaching mode	256-point mode	512-point mode	Solenoid Valve Mode 1	Solenoid Valve Mode 2
		Positioning Points	64 points	64 points	256 points	512 points	7 points	3 points
		Zone signal	○	x	x	x	○	○
		P-zone signal	○	○	○	x	○	○
1A	24V		P24					
2A	24V		P24					
3A	–		NC					
4A	–		NC					
5A	Input	IN0	PC1	PC1	PC1	PC1	ST0	ST0
6A		IN1	PC2	PC2	PC2	PC2	ST1	ST1 (JOG+)
7A		IN2	PC4	PC4	PC4	PC4	ST2	ST2 (-)
8A		IN3	PC8	PC8	PC8	PC8	ST3	–
9A		IN4	PC16	PC16	PC16	PC16	ST4	–
10A		IN5	PC32	PC32	PC32	PC32	ST5	–
11A		IN6	–	MODE	PC64	PC64	ST6	–
12A		IN7	–	JISL	PC128	PC128	–	–
13A		IN8	–	JOG+	–	PC256	–	–
14A		IN9	BKRL	JOG-	BKRL	BKRL	BKRL	BKRL
15A		IN10	RMOD	RMOD	RMOD	RMOD	RMOD	RMOD
16A		IN11	HOME	HOME	HOME	HOME	HOME	–
17A		IN12	*STP	*STP	*STP	*STP	*STP	–
18A		IN13	CSTR	CSTR/PWRT	CSTR	CSTR	–	–
19A		IN14	RES	RES	RES	RES	RES	RES
20A	IN15	SON	SON	SON	SON	SON	SON	
1B	Output	OUT0	PM1	PM1	PM1	PM1	PE0	LSO
2B		OUT1	PM2	PM2	PM2	PM2	PE1	LS1 (TRQS)
3B		OUT2	PM4	PM4	PM4	PM4	PE2	LS2 (-)
4B		OUT3	PM8	PM8	PM8	PM8	PE3	–
5B		OUT4	PM16	PM16	PM16	PM16	PE4	–
6B		OUT5	PM32	PM32	PM32	PM32	PE5	–
7B		OUT6	MOVE	MOVE	PM64	PM64	PE6	–
8B		OUT7	ZONE1	MODES	PM128	PM128	ZONE1	ZONE1
9B		OUT8	PZONE	PZONE	PZONE	PM256	PZONE	PZONE
10B		OUT9	RMDS	RMDS	RMDS	RMDS	RMDS	RMDS
11B		OUT10	HEND	HEND	HEND	HEND	HEND	HEND
12B		OUT11	PEND	PEND/WEND	PEND	PEND	PEND	–
13B		OUT12	SV	SV	SV	SV	SV	SV
14B		OUT13	* EMGS	* EMGS	* EMGS	* EMGS	* EMGS	* EMGS
15B		OUT14	* ALM	* ALM	* ALM	* ALM	* ALM	* ALM
16B	OUT15	LOAD/TRQS	–	LOAD/TRQS	LOAD/TRQS	LOAD/TRQS	–	
17B	–		NC					
18B	–		NC					
19B	0V		N					
20B	0V		N					

(Note) The names of signals above inside () are functions before the unit returns home.
 (Note) Signals with asterisks (*) are normally ON, and OFF during operation.

■ Solenoid valve type (PCON-CY)

Pin No.	Classification		Parameters (select PIO pattern)	
			0	1
			Solenoid valve mode 0	Solenoid valve mode 1
		Positioning Points	3 points	3 points
		Zone signal	x	x
		P-zone signal	x	○
1	24V			
2	0V			
3	Input	IN0	ST0	ST0
4		IN1	ST1 (JOG+)	ST1 (JOG+)
5		IN2	ST2 (RES)	ST2 (RES)
6		IN3	SON	SON
7	Output	OUT0	LS0	PE0
8		OUT1	LS1 (TRQS)	PE1 (TRQS)
9		OUT2	LS2 (-)	PE2 (-)
10		OUT3	SV	PZONE
11		OUT4	HEND	HEND
12		OUT5	* ALM	* ALM

(Note) The names of signals above inside () are functions before the unit returns home.
 (Note) Signals with asterisks (*) are normally ON, and OFF during operation.

■ Pulse Train Type (PCON-PL/PO)

Pin No.	Classification		Parameters (select PIO pattern)	
			0	1
			Standard mode	Push mode
		Positioning Points	–	–
		Zone signal	x	x
		P-zone signal	x	x
1	24V			
2	0V			
3	Input	IN0	SON	SON
4		IN1	TL	TL
5		IN2	HOME	HOME
6		IN3	RES	RES / DCLR
7	Output	OUT0	SV	SV
8		OUT1	INP	INP / TLR
9		OUT2	HEND	HEND
10		OUT3	* ALM	* ALM
11	Input		* PP	* PP
12			PP	PP
13			* NP	* NP
14			NP	NP

(Note) Signals with asterisks (*) are normally ON, and OFF during operation.

Pulse train input type wiring diagram

■ Differential Receiver Method (PCON-PL)

Max. input pulse frequency : Max. 200 kpps
 Cable Length : Max. 10m

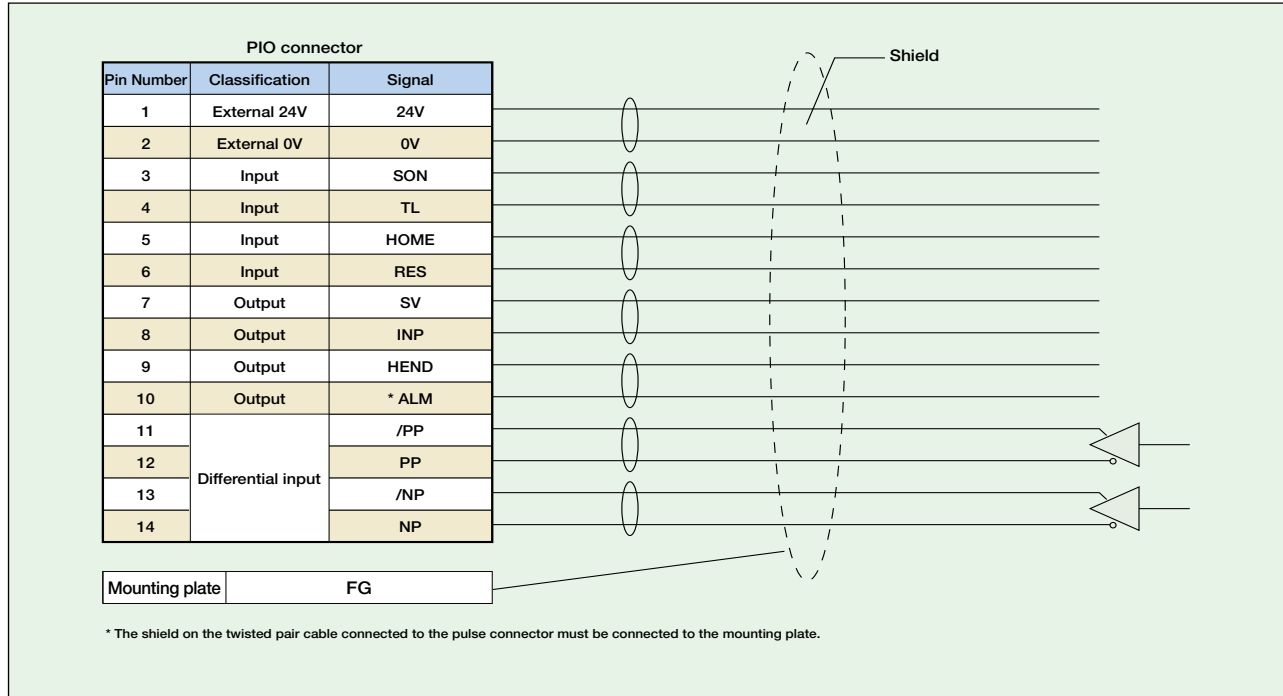

■ Open Collector Method (PCON-PO)

Max. input pulse frequency : Max. 60 kpps
 Cable Length : Max. 2m

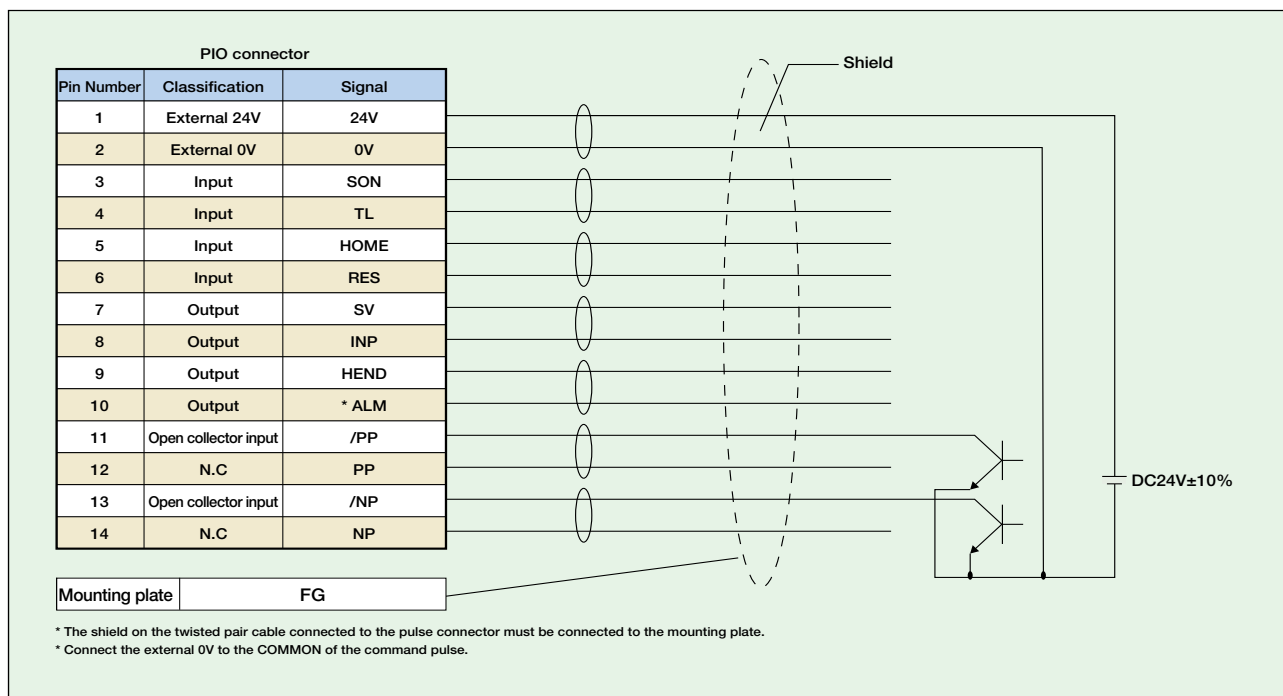

Command Pulse Input State

Command pulse train state		Input terminal	During forward operation	During reversed operation
Negative logic	Forward pulse train	PP•/PP		
	Reversed pulse train	NP•/NP		
	The forward pulse train causes the motor to rotate forward, and the reverse pulse train causes the motor to rotate in reverse.			
	Pulse train	PP•/PP		
	Symbols	NP•/NP	Low	High
	The command pulse is used for the amount of motor rotation, and the command symbol is used for rotational direction.			
Positive logic	Forward pulse train	PP•/PP		
	Reversed pulse train	NP•/NP		
	The forward pulse train causes the motor to rotate forward, and the reverse pulse train causes the motor to rotate in reverse.			
	Pulse train	PP•/PP		
	Symbols	NP•/NP	High	Low
	The command pulse is used for the amount of motor rotation, and the command symbol is used for rotational direction.			
A/B phase pulse train	PP•/PP			
	NP•/NP			
An A/B phase pulse with a 90° phase difference (multiplier is 4) is used to generate commands for the amount of rotation and rotational direction.				

Table of specifications

Item	Specifications						
	CF	C	CG	CY	PL	PO	SE
Controller type							
Connected actuator (*1)	RCP2-RA10C RCP2-HS8C (R) RCP2W-SA16C	RCP3 / RCP2 series actuator (Note 1)					
Number of control axes	1-axis						
Operating method	Positioner type			Solenoid valve type	Pulse train input type		Serial communication type
Positioning Points	512 points			3 points	-		64 points
Backup memory	EEPROM						
I/O connector	40-pin connector			12-pin connector	14-pin connector		None
Number of I/O	16 input points/16 output points			4 input points/6 output points	4 input points/4 output points		None
I/O power	External supply DC24V±10%						
Serial Communication	RS485 1ch						
Peripheral device communication cable	CB-PAC-PIO □□□			CB-PACY-PIO □□□	CB-PACPU-PIO □□□		CB-RCB-CTL002
Command pulse train input method	-			Differential line driver		Open collector	
Max. input pulse frequency (Note 2)	-			Max. 200 kpps		Max. 60 kpps	
Position detection method	Incremental encoder						
Drive-source cutoff relay at emergency stop	Integrated			External			
Forced release of electromagnetic brake	Brake release switch ON/OFF			ON/OFF terminal signal inside the power terminal for brake release			
Input Supply Voltage	DC 24 V ± 10%						
Power Supply Capacity	Max. 6A (*2)	2A max.					
Dielectric strength voltage	DC500V 1MΩ						
Vibration resistance	XYZ directions		10 to 57Hz, One side amplitude: 0.035mm (continuous), 0.075mm (intermittent) 58 to 150Hz, 4.9m/s² (continuous), 9.8m/s² (intermittent)				
Ambient operating temperature	0 ~ 40°C						
Ambient operating humidity	10 - 95% (non-condensing)						
Ambient operating atmosphere	Without corrosion gases						
Protection class	IP20						
Weight	Approx. 320g	Approx. 300g			Approx. 130g		

(Note 1) The high-thrust type (RA10C), high-speed type (HS8C/HS8R) and waterproof type (RCP2W-SA16) cannot be operated.
 (Note 2) With the open collector specification, keep the maximum input frequency to 60 kpps or below to prevent malfunction. For applications exceeding 60kpps, use the differential line driver.
 (*1) RCP2-RA10C/HS8C/HS8R and RCP2W-SA16C can only operate with PCON-CF.
 Other RCP2 / RCP3 Series actuators can be operated with C / CG / CY / PL / PO / SE.
 (*2) Inrush current peak: 10A

External Dimensions

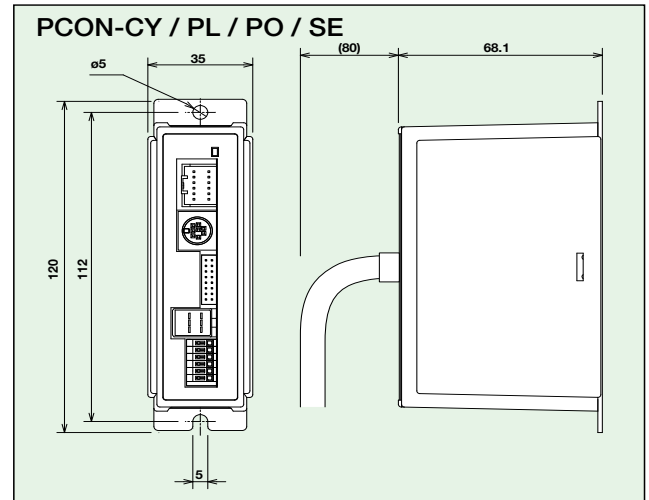
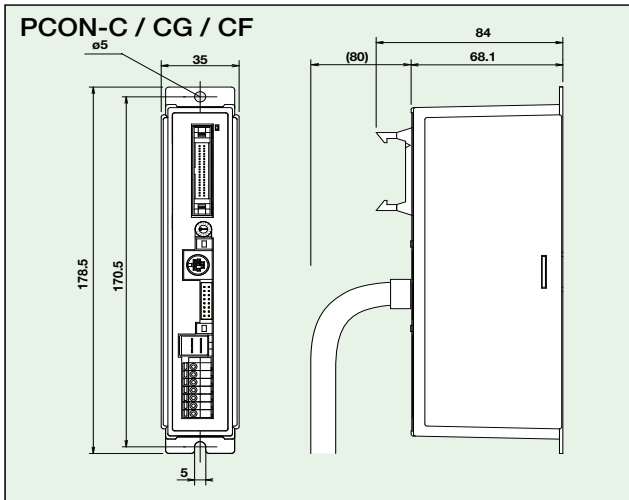

Name of Each Part

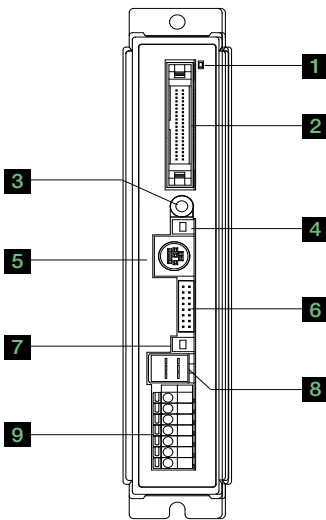

C / CG / CF type

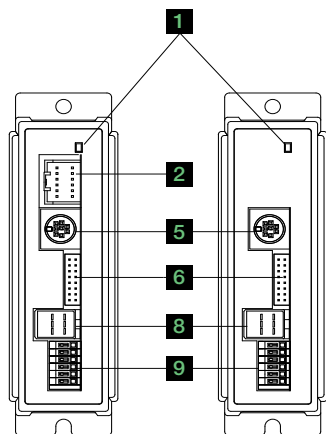

CY / PL / PO Type

SE Type

* PIO connectors are:
CY: 12 pin
PL/PO: 14 pin

1 LED display

These LED colors indicate the condition of the controller.

Lit (green) Servo ON Lit (red) Alarm activated Unit Servo OFF Blinking (green) Automatic servo-off
Emergency stop

2 PIO connector

Connects a cable for communicating with a PLC or other external equipment.

3 Address-setting rotary switch

This switch sets the addresses for controllers used when the unit is linked with other controllers.

4 Mode switch

Switches between manual teaching operations (MANU) and automatic operations (AUTO).

Operation details

MANU	I/O commands are not accepted. Data can be written from a teaching pendant or PC.
AUTO	I/O commands are valid, while operations from a teaching pendant or PC are not accepted. However, monitoring is possible.

5 SIO connector

Connects a teaching pendant, PC cable, controller, or gateway unit to a controller.

Operation details

Pin No.	Signal	Name	Remarks
1	SGA	Positive side, RS485 differential signal	
2	SGB	Negative side, RS485 differential signal	
3	5V	+5V output	For RS232/485 conversion
4	ENBL	Enable signal	
5	EMGA	EMG line connection to external equipment	
6	24V	24-V power for T/P	For T/P
7	0V	GND	
8	EMGB	EMG line connection to external equipment	
9	0V	EMG line connection to external equipment ground	

6 Encoder brake connector

Connects the encoder/brake cable for the actuator.

7 Brake release switch

This switch forces the brake to release.

8 Motor connector

Connects the motor cable for the actuator.

9 Power terminal block

Main power for controller(s), emergency stop

C / CG type

Terminal number	Signal	Name
7	S1	External drive-source cutoff for TP_ EMG terminal
6	S2	
5	MPI	Motor drive-source cutoff terminal
4	MPO	Motor drive-source cutoff terminal
3	24V	Positive side of the 24-V power supply
2	0V	Negative side of the 24-V power supply
1	EMG	EMG signal (application of 24 V)

CY / PL / PO / SE type

Terminal number	Signal	Name
6	BK	BK release
5	MPI	Motor drive-source cutoff terminal
4	MPO	Motor drive-source cutoff terminal
3	24V	Positive side of the 24-V power supply
2	0V	Negative side of the 24-V power supply
1	EMG	EMG signal (application of 24 V)

- Slider Type
- Mini
- Standard
- Controllers Integrated
- Pod Type
- Mini
- Standard
- Controllers Integrated
- Table/Arm /FlatType
- Mini
- Standard
- Gripper/ Rotary Type
- Linear Servo Type
- Cleanroom Type
- Splash-Proof
- Controllers
- PMEC /AMEC
- PSEP /ASEP
- ROBO NET
- ERC2
- PCON
- ACON
- SCON
- PSEL
- ASEL
- SSEL
- XSEL
- Pulse Motor
- Servo Motor (24V)
- Servo Motor (200V)
- Linear Servo Motor

- Slider Type
- Mini
- Standard
- Controllers Integrated
- Rod Type
- Mini
- Standard
- Controllers Integrated
- Table/Arm /FlatType
- Mini
- Standard
- Gripper/ Rotary Type
- Linear Servo Type
- Cleanroom Type
- Splash-Proof
- Controllers
- PMEC /AMEC
- PSEP /ASEP
- ROBO NET
- ERC2
- PCON
- ACON
- SCON
- PSEL
- ASEL
- SSEL
- XSEL
- Pulse Motor
- Servo Motor (24V)
- Servo Motor (200V)
- Linear Servo Motor

Option

Teaching Pendant

- Features This is a teaching device that provides information on functions such as the position input, test runs, and monitoring.
- Model **CON-PT-M-ENG** (Touch panel teaching pendant)
CON-T-ENG (Standard type)
RCM-E-ENG (Simple teaching pendant)

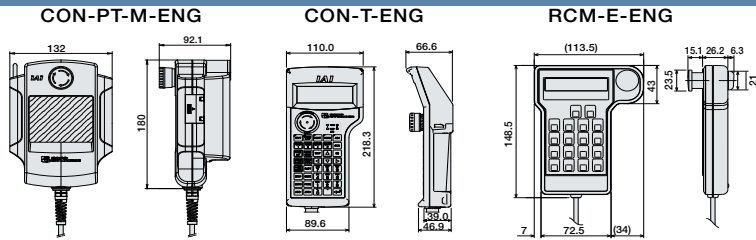

- Configuration

Note: The version of RCM-E-ENG that can be used with ROBOTNET is 2.08 or later.

Specifications

Item	CON-PT-M-ENG	CON-T-ENG	RCM-E-ENG
Data input	○	○	○
Actuator motion	○	○	○
Ambient Operating temp/humidity	Temp: 0~40°C; Humidity: 85% RH or below		
Ambient Operating atmosphere	No corrosive gases. Especially no dust.		
Protection class	IP40	IP54	-
Weight	Approx. 750g	Approx. 400g	Approx. 400g
Cable length	5m		
Display	3-color LED touch panel with backlight	20 char. × 4 lines LCD display	16 char. × 2 lines LCD display

CON-T-ENG Options

- Wall-mounting hook Model HK-1
- Strap Model STR-1

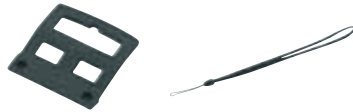

PC Software (Windows Only)

- Features A startup support software for inputting positions, performing test runs, and monitoring. With enhancements for adjustment functions, the startup time is shortened.

- Model **RCM-101-MW** (External device communications cable + RS232 conversion unit)

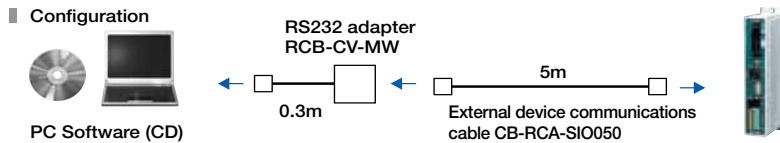

- Model **RCM-101-USB** (External device communications cable + USB adapter + USB cable)

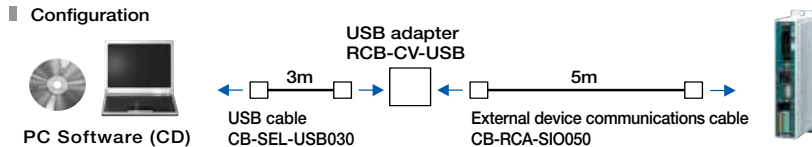

Spare Parts

When you need spare parts after purchasing the product, such as when replacing a cable, refer to the list of models below.

Motor Cable for RCP2

Model **CB-RCP2-MA** * The standard cable for the motor cable is the robot cable.

* Enter the cable length (L) into . Compatible to a maximum of 20 meters. Ex.: 080 = 8 m

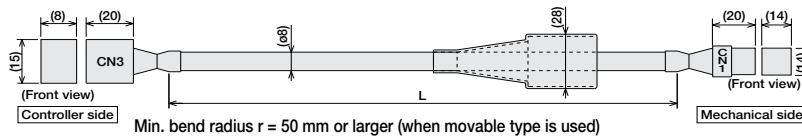

Cable color	CN3		M cable	CN1		Signal
	A	B		A	B	
Orange	A	A1	1	A	Yellow	SLP-06V (JST)
Gray	VMM	A2	2	VMM	Gray	
White	B	A3	3	A	Orange	
Yellow	A	B1	4	B	Yellow (Green)	
Pink	VMM	B2	5	VMM	Pink	
Yellow (Green)	B	B3	6	B	White	

Encoder Cable/Encoder Robot Cable for RCP2

Model **CB-RCP2-PB** / **CB-RCP2-PB** **-RB** * The standard cable for the encoder cable is the normal cable. * Enter the cable length (L) into . Compatible to a maximum of 20 meters. Ex.: 080 = 8 m

* The standard cable for the encoder cable is the normal cable. * Enter the cable length (L) into . Compatible to a maximum of 20 meters. Ex.: 080 = 8 m

Min. bend radius r = 50 mm or larger (when movable type is used)
 * Only robot cable is to be used in a cable track.

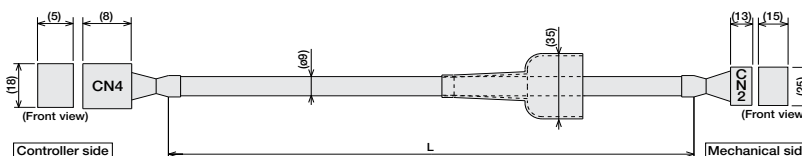

Cable color	C N 4		Signal	Pin No.	Cable color	C N 2
	Standard Cable	Robot Cable				
Blue (Red 1)	Orange (Black 2)	L S +	16	16	Blue	Pink (Black 1)
White	Orange (Red 2)	L S -	15	15	White	Pink (Red 1)
Red	Orange (Black 1)	B K +	14	14	Red	Orange (Black 1)
Gray	Orange (Red 1)	B K -	13	13	Gray	Orange (Red 1)
Brown	Light Gray (Black 1)	E N A	12	12	Brown	Light Gray (Red 1)
Green	Light Gray (Red 1)	E N A	11	11	Green	Light Gray (Red 1)
Purple	White (Black 1)	E N B	10	10	Purple	White (Black 1)
Pink	White (Red 1)	E N B	9	9	Pink	White (Red 1)
Yellow	Pink	E N B	8	8	Yellow	Yellow (Black 1)
Yellow	Yellow (Black 1)	V P S	7	7	Yellow	Yellow (Black 1)
Orange	Pink (Red 1)	V B B	6	6	Orange	Blue
Blue	Pink (Black 1)	GND	5	5	Blue	Pink (Red 1)
-	-	(NC)	4	4	-	-
-	-	(NC)	3	3	-	-
-	-	(NC)	2	2	-	-
Ground	Ground	F.G	1	1	Ground	Ground

Encoder Cable / Encoder Robot Cable for the RCP2 High-speed Type / High-thrust Type / Waterproof Type

Model **CB-RFA-PA** [] [] [] [] / **CB-RFA-PA** [] [] [] [] -**RB** * The standard cable for the encoder cable is the normal cable. * Enter the cable length (L) into [] [] []. Compatible to a maximum of 20 meters. A robot cable can be specified as an option. Ex.: 080 = 8 m

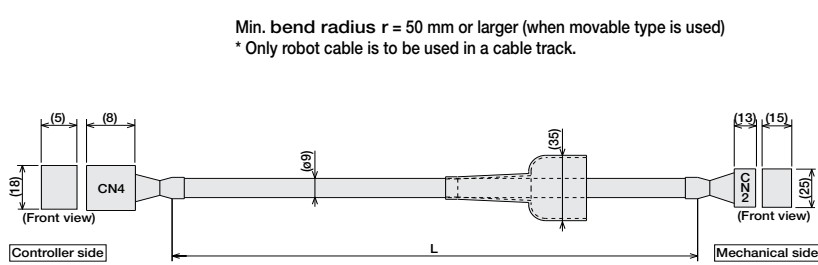

CN2		Signal		Pin No.	
Robot Cable	Standard Cable				
-	-	Spard	Spard	16	
-	-	Spard	Spard	15	
Orange (Black 1)	Red	BK+	BK+	14	
Orange (Red 1)	Gray	BK-	BK-	13	
Light Gray (Black 1)	Brown	ENA	ENA	12	
Light Gray (Red 1)	Green	ENA	ENA	11	
White (Black 1)	Purple	ENB	ENB	10	
White (Red 1)	Pink	ENB	ENB	9	
-	-	Spard	Spard	8	
Yellow (Black 1)	Yellow	VPS	VPS	7	
Pink (Black 1)	Blue	GND	GND	5	
Pink (Red 1)	Orange	SV	SV	4	
-	-	-	-	3	
-	-	-	-	2	
-	-	Ground	F.S	1	

Housing: PHDR-16VS (JST)
 Contact: SPHD-001T-P0.5

CN1		Signal		Pin No.		Cable color	
Robot Cable	Standard Cable						
1	ENA	Brown	Light Gray (Black 1)	1	A		
2	ENB	Green	Light Gray (Red 1)	2	B		
3	ENB	Purple	White (Black 1)	3	A		
4	ENB	Pink	White (Red 1)	4	B		
5	-	-	-	5	A		
6	-	-	-	6	B		
7	-	-	-	7	A		
8	-	-	-	8	B		
9	GND	Blue	Pink (Red 1)	9	A		
10	-	-	-	10	B		
11	VPS	Yellow	Yellow (Black 1)	11	A		
12	SV	Orange	Pink (Red 1)	12	B		
13	-	-	-	13	A		
14	-	-	-	14	B		
15	-	-	-	15	A		
16	BK+	Red	Orange (Black 1)	16	A		
17	BK-	Gray	Orange (Red 1)	17	B		
18	F.S	Ground	Ground	18	A		

Housing: XNP-15V (JST)
 Contact: BXA-001T-P0.6
 Retainer: MS-09V

Motor-Encoder Integrated Type Cable for RCP3/RCP2 (Limited to RCP2-GRSS/GRLS/GRST/SRA4R/SRGS4R/MSGD4R)

Model **CB-PCS-MPA** [] [] [] * The standard cable is robot cable. * Enter the cable length (L) into [] [] []. Compatible to a maximum of 20 meters. Ex.: 080 = 8 m

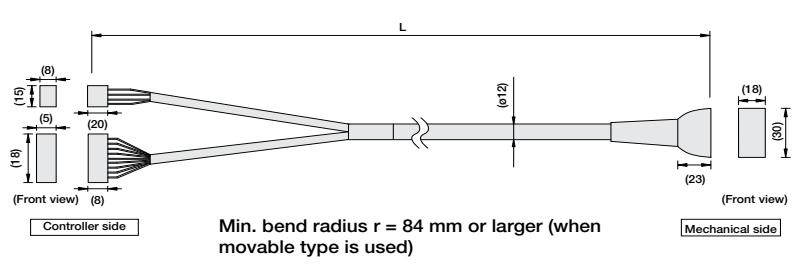

Signal	Pin No.	(Wire color)	Pin No.	Signal
A	B1	Black	A1	A
VMM	A2	White	B1	VMM
/A	A1	Red	A2	/A
B	B3	Red	B2	B
VMM	B2	Green	A3	VMM
/B	A3	Yellow	B3	/B
-	-	Brown	A4	NC
-	-	-	B4	NC
BK+	14	Pink (Red)	A5	BK+
LS+	16	Pink (Blue)	B5	BK-
LS-	15	White (Red)	A6	LS+
A-	12	White (Blue)	B6	LS-
A+	11	Orange (Red)	A7	A+
B+	10	Orange (Blue)	B7	A-
B-	9	Gray (Red)	A8	B+
NC	8	Gray (Blue)	B8	B-
VPS	7	Orange (Blue)	A9	NC
VCC	6	Gray (Red)	B9	VPS
GND	5	Gray (Blue)	A10	VCC
NC	4	Shield	B10	GND
FG	1	-	A11	NC
-	-	-	B11	FG

Positioner I/O Cable (for PCON-C/CG)

Model **CB-PAC-PIO** [] [] [] * Enter the cable length (L) into [] [] []. Compatible to a maximum of 10 meters. Ex.: 080 = 8 m

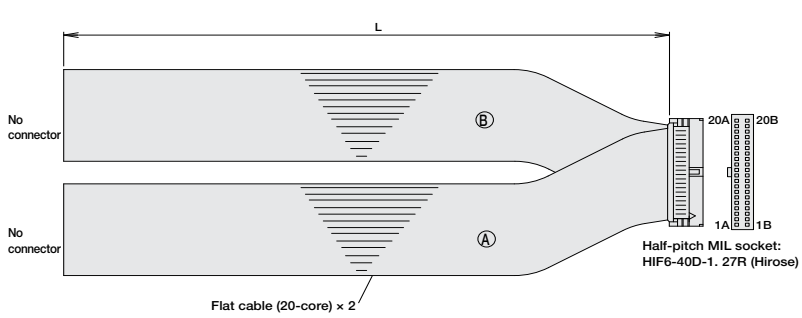

No.	Signal	Cable Color	Wire	No.	Signal	Cable Color	Wire
1A	24V	Brown-1	1B	OUT0	Brown-3		
2A	24V	Red-1	2B	OUT1	Red-3		
3A	-	Orange-1	3B	OUT2	Orange-3		
4A	-	Yellow-1	4B	OUT3	Yellow-3		
5A	IN0	Green-1	5B	OUT4	Green-3		
6A	IN1	Blue-1	6B	OUT5	Blue-3		
7A	IN2	Purple-1	7B	OUT6	Purple-3		
8A	IN3	Gray-1	8B	OUT7	Gray-3		
9A	IN4	White-1	9B	OUT8	White-3		
10A	IN5	Black-1	10B	OUT9	Black-3		
11A	IN6	Brown-2	11B	OUT10	Brown-4		
12A	IN7	Red-2	12B	OUT11	Red-4		
13A	IN8	Orange-2	13B	OUT12	Orange-4		
14A	IN9	Yellow-2	14B	OUT13	Yellow-4		
15A	IN10	Green-2	15B	OUT14	Green-4		
16A	IN11	Blue-2	16B	OUT15	Blue-4		
17A	IN12	Purple-2	17B	-	Purple-4		
18A	IN13	Gray-2	18B	-	Gray-4		
19A	IN14	White-2	19B	OV	White-4		
20A	IN15	Black-2	20B	OV	Black-4		

Solenoid Valve Type I/O Cable (for PCON-CY)

Model **CB-PACY-PIO** [] [] [] * Enter the cable length (L) into [] [] []. Compatible to a maximum of 10 meters. Ex.: 080 = 8 m

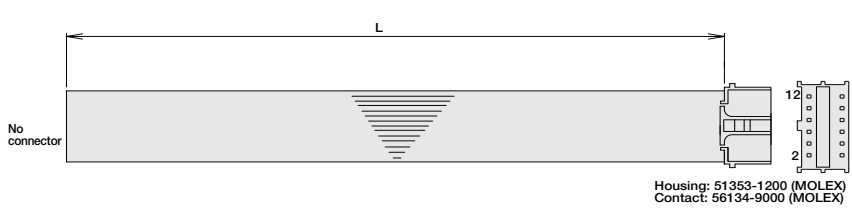

No.	Signal	Cable Color	Wire
1	24V	Brown-1	
2	OV	Red-1	
3	IN0	Orange-1	
4	IN1	Yellow-1	
5	IN2	Green-1	
6	IN3	Blue-1	
7	OUT0	Purple-1	
8	OUT1	Gray-1	
9	OUT2	White-1	
10	OUT3	Black-1	
11	OUT4	Brown-2	
12	OUT5	Red-2	

Pulse Train Control I/O Cable (for PCON-PL/PO)

Model **CB-PACPU-PIO** [] [] [] * Enter the cable length (L) into [] [] []. Compatible to a maximum of 10 meters. Ex.: 080 = 8 m

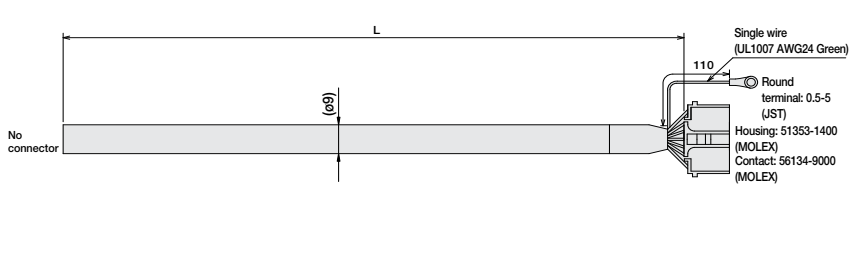

No.	Signal	Cable Color	Wire
1	IO 24V	Black	
2	IO 24V	White/Black	
3	IN0	Red	
4	IN1	White/Red	
5	IN2	Green	
6	IN3	White/Green	
7	OUT0	Yellow	
8	OUT1	White/Yellow	
9	OUT2	Brown	
10	OUT3	White/Brown	
11	PP	Blue	
12	PG	White/Blue	
13	NP	Gray	
14	NG	White/Gray	
1	FG	White/Gray	AWG24

- Slider Type
- Mini
- Standard
- Controllers Integrated
- Rod Type
- Mini
- Standard
- Controllers Integrated
- Table/Arm /FlatType
- Mini
- Standard
- Controllers Integrated
- Table/Arm /FlatType
- Mini
- Standard
- Gripper/ Rotary Type
- Linear Servo Type
- Cleanroom Type
- Splash-Proof
- Controllers
- PMEC /AMEC
- PSEP /ASEP
- ROBO NET
- ERC2
- PCON
- ACON
- SCON
- PSEL
- ASEL
- SSEL
- XSEL
- Pulse Motor
- Servo Motor (24V)
- Servo Motor (200V)
- Linear Servo Motor