

RCP2W-RA4C ROBO Cylinder Splash-proof Rod Type 45mm Width Pulse Motor Coupled

Configuration: **RCP2W** — **RA4C** — **I** — **42P** — — — — —

Series — Type — Encoder — Motor — Lead — Stroke — Compatible Controllers — Cable Length — Option

I: Incremental Type 42P: Pulse motor
 * The simple absolute encoder is also considered type "I".
 42 □ size
 10 : 10mm
 5 : 5mm
 2.5 : 2.5mm
 50: 50mm
 300: 300mm (50mm pitch increments)

P1 : PCON
 RPCON
 PSEL
 P3 : PMEC
 PSEP

N : None
 P : 1m
 S : 3m
 M : 5m
 X □ : Custom
 R □ : Robot Cable

B : Brake-Equipped
 FL : With Flange
 FT : With Foot bracket
 NM : Reversed-home

* See page Pre-35 for explanation of each code that makes up the configuration name.



Technical References P. A-5

- POINT** Notes on Selection
- (1) When the stroke increases, the maximum speed will drop to prevent the ball screw from reaching the critical rotational speed. Use the actuator specification table below to check the maximum speed at the stroke you desire.
 - (2) Since the RCP2 series use a pulse motor, the load capacity decreases at high speeds. Check in the Speed vs. Load Capacity graph on the above right to see if your desired speed and load capacity are supported.
 - (3) The load capacity is based on operation at an acceleration of 0.2G. 0.2G is the upper limit for the acceleration.
 - (4) The cable joint connector is not splash-proof; secure it in a place that is not prone to water spills.

Speed vs. Load Capacity
 Due to the characteristics of the Pulse motor, the RCP2 series' load capacity decreases at high speeds. In the table below, check if your desired speed and load capacity are supported.

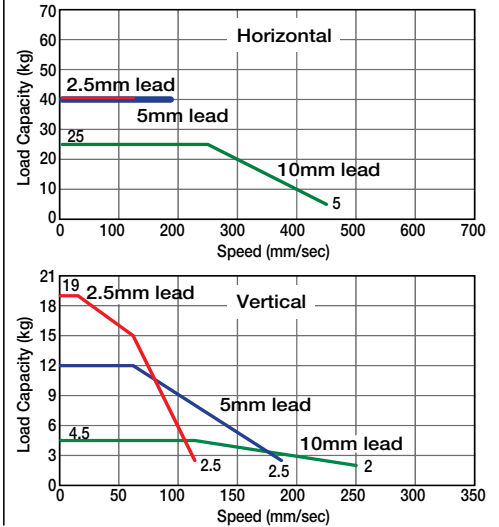

Actuator Specifications					
Lead and Load Capacity			Stroke and Maximum Speed		
Model	Lead (mm)	Max. Load Capacity (Note 1)		Stroke (mm)	Stroke / Lead
		Horizontal (kg)	Vertical (kg)		
RCP2W-RA4C-I-42P-10-①-②-③-④	10	~25	~4.5	150	10
RCP2W-RA4C-I-42P-5-①-②-③-④	5	40	~12	284	5
RCP2W-RA4C-I-42P-2.5-①-②-③-④	2.5	40	~19	358	2.5

Legend ① Stroke ② Compatible controller ③ Cable length ④ Options
 (Note 1) Please note that the maximum load capacity decreases as the speed increases.
 (Note 2) See page A-69 for push force graph. * The value inside < > applies to vertical setting. (Unit: mm/s)

① Stroke List

Stroke (mm)	Standard Price
50	-
100	-
150	-
200	-
250	-
300	-

③ Cable List

Type	Cable Symbol	Standard Price
Standard	P (1m)	-
	S (3m)	-
	M (5m)	-
Special Lengths	X06 (6m) ~ X10 (10m)	-
	X11 (11m) ~ X15 (15m)	-
	X16 (16m) ~ X20 (20m)	-
Robot Cable	R01 (1m) ~ R03 (3m)	-
	R04 (4m) ~ R05 (5m)	-
	R06 (6m) ~ R10 (10m)	-
	R11 (11m) ~ R15 (15m)	-
	R16 (16m) ~ R20 (20m)	-

* See page A-39 for cables for maintenance.

④ Option List

Name	Option Code	See Page	Standard Price
Brake-Equipped	B	→ A-25	-
With Flange	FL	→ A-27	-
With Foot bracket	FT	→ A-29	-
Reversed-home	NM	→ A-33	-

Actuator Specifications

Item	Description
Drive System	Ball screw ø8mm C10 grade
Positioning Repeatability	±0.02mm
Lost Motion	0.1 mm or less
Rod diameter	ø22mm
Rod non-rotational accuracy	±1.5 degrees
Protection Structure	IP65
Ambient Operating Temp./Humidity	0~40°C, 85%RH or less (Non-condensing)

Dimensions

CAD drawings can be downloaded from IAI website. www.intelligentactuator.com



For Special Orders P. A-9

Note:
Please don't apply an external force coming from a direction other than that of the rod's advance.
The rotation stopper may break if a force coming from right angle or rotating direction is applied to the rod.

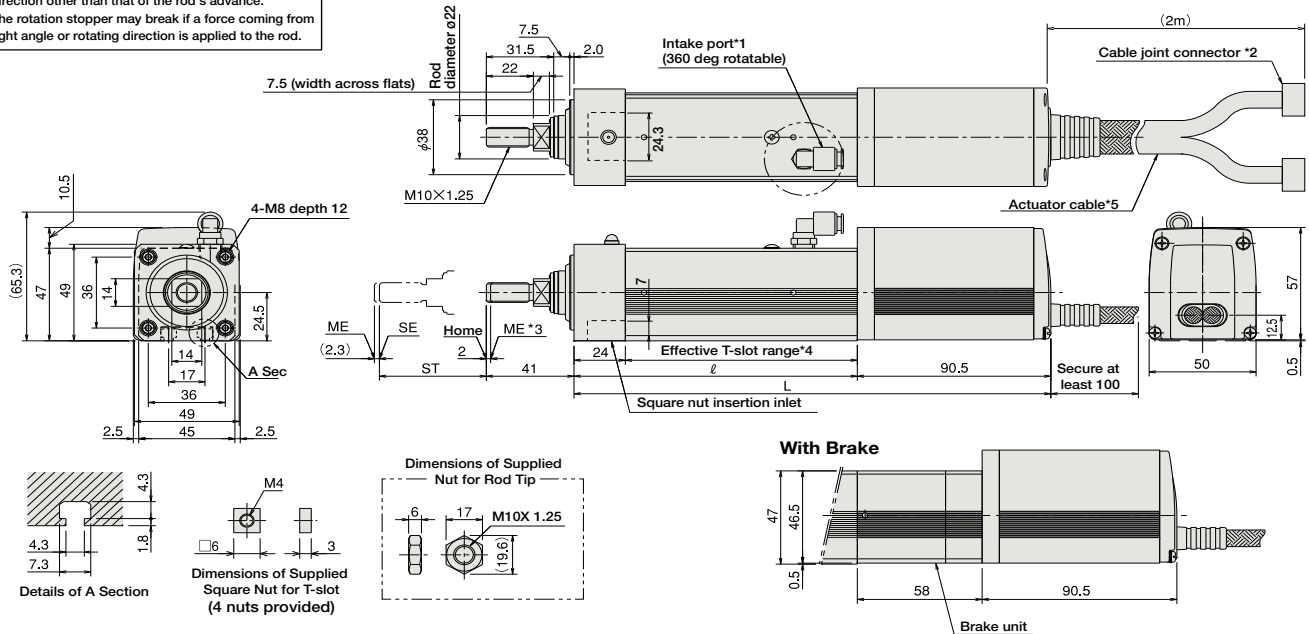

- * 1. Intake/exhaust port is the air exhaust tube in the main body. Insert OD $\phi 6$ mm tube and use it extended to a place that is not prone to water spills or intake.
- * 2. Connect motor encoder cable. See page A-39 for details on cables.
The cable joint connector is not splash-proof; therefore, please secure it in a place that is not prone to water spills.
- * 3. When homing, the rod moves to the ME; therefore, please watch for any interference with the surrounding objects.
ME : Mechanical End
SE : Stroke end
The dimensions enclosed in "()" are reference dimensions.
- * 4. Please note that there is no T-slot in the bottom of brake unit.
- * 5. The actuator cable is not a robot cable (flex resistant cable); therefore, please don't use it for movable parts such as cable track.

* Adding a brake increases overall length by 58mm and its weight by 0.4kg.

■ Dimensions/Weight by Stroke

Stroke	50	100	150	200	250	300
ℓ	132.5	182.5	232.5	282.5	332.5	382.5
L	223	273	323	373	423	473
Weight (kg)	1.9	2.1	2.2	2.5	2.9	3.1

② Compatible Controllers

The RCP2W series actuators can operate with the controllers below. Select the controller according to your usage.

Name	External View	Model	Description	Max. Positioning Points	Input Voltage	Power Supply Capacity	Standard Price	See Page
Solenoid Valve Type		PMEC-C-42PI-NP-2-①	Easy-to-use controller, even for beginners.	3 points	AC100V AC200V	See P481	-	→ P477
		PSEP-C-42PI-NP-2-0	Operable with same signal as solenoid valve. Supports both single and double solenoid types.					→ P487
Splash-Proof Solenoid Valve Type		PSEP-CW-42PI-NP-2-0	No homing necessary with simple absolute type.					
Positioner Type		PCON-C-42PI-NP-2-0	Positioning possible for up to 512 points	512 points				
Safety Category Compliant Positioner Type		PCON-CG-42PI-NP-2-0						
Pulse Train Input Type (Differential Line Driver)		PCON-PL-42PI-NP-2-0	Differential line driver support Pulse Train Input Type	(-)	DC24V	2A max.		→ P525
Pulse Train Input Type (Open Collector)		PCON-PO-42PI-NP-2-0	Open Collector Pulse Train Input Type					
Serial Communication Type		PCON-SE-42PI-N-0-0	Dedicated to serial communication	64 points				
Field Network Type		RPCON-42P	Dedicated to field network	768 points				→ P503
Program Control Type		PSEL-C-1-42PI-NP-2-0	Programmed operation is possible Can operate up to 2 axes	1500 points				→ P557

* This is for the single-axis PSEL.
*① is a placeholder for the power supply voltage (1:100V / 2:100-240V).

- Slider Type
- Mini
- Standard
- Controllers Integrated
- Rod Type
- Mini
- Standard
- Controllers Integrated
- Table/Arm /Flat Type
- Mini
- Standard
- Gripper/ Rotary Type
- Linear Servo Type
- Cleanroom Type
- Splash-Proof
- Controllers
- PMEC /AMEC
- PSEP /ASEP
- ROBO NET
- ERC2
- PCON
- ACON
- SCON
- PSEL
- ASEL
- SSEL
- XSEL
- Pulse Motor
- Servo Motor (24V)
- Servo Motor (200V)
- Linear Servo Motor