

RCACR-SA6C

Cleanroom ROBO Cylinder Slider Coupling Type 58mm Width 24V Servo Motor Aluminum Base

■ Configuration: **RCACR-SA6C** - [] - **30** - [] - [] - [] - []

Series — Type — Encoder — Motor — Lead — Stroke — Compatible Controllers — Cable Length — Option

I : Incremental 30 : 30W servo motor
 A : Absolute motor
 * The absolute model can only use ASEL. The simple absolute type is considered an incremental model.

12: 12mm 50: 50mm A1: ACON N : None
 6: 6mm 3: 3mm 600: 600mm (50mm pitch increments) A3: AMEC ASEP P : 1m S : 3m M : 5m X [] : Custom R [] : Robot cable

* See page Pre-35 for an explanation of the naming convention. See Options below

Power-saving



Technical References P. A-5

- POINT** Notes on Selection
- (1) When the stroke increases, the maximum speed will drop to prevent the ball screw from reaching the critical rotational speed. Use the actuator specification table below to check the maximum speed at the stroke you desire.
 - (2) The load capacity is based on operation at an acceleration of 0.3G (0.2G for the 3mm-lead model). This is the upper limit of the acceleration.

Actuator Specifications

■ Lead and Load Capacity

Model	Motor Output (W)	Lead (mm)	Max. Load Capacity		Rated Thrust (N)	Stroke (mm)
			Horizontal (kg)	Vertical (kg)		
RCACR-SA6C-①-30-12-②-③-④-⑤	30	12	6	1.5	24.2	50 ~ 600 (50mm increments)
RCACR-SA6C-①-30-6-②-③-④-⑤		6	12	3	48.4	
RCACR-SA6C-①-30-3-②-③-④-⑤		3	18	6	96.8	

■ Stroke, Max. Speed/Suction Volume

Stroke Lead	50 ~ 450 (50mm increments)	500 (mm)	550 (mm)	600 (mm)	Suction Volume (Nl/min)
12	800	760	640	540	50
6	400	380	320	270	30
3	200	190	160	135	15

Legend: ① Encoder ② Stroke ③ Compatible controller ④ Cable length ⑤ Options (Unit: mm/s)

① Encoder & Stroke List

Stroke (mm)	Standard Price	
	Encoder Type	
	Incremental	Absolute
50	-	-
100	-	-
150	-	-
200	-	-
250	-	-
300	-	-
350	-	-
400	-	-
450	-	-
500	-	-
550	-	-
600	-	-

⑤ Option List

Name	Option Code	See Page	Standard Price
Brake	B	→ A-25	-
Foot bracket	FT	→ A-29	-
Home sensor	HS	→ A-32	-
Power-saving	LA	→ A-32	-
Reversed-home	NM	→ A-33	-
Intake port mounted on opposite side	VR	→ A-38	-

④ Cable List

Type	Cable Symbol	Standard Price
Standard Type	P (1m)	-
	S (3m)	-
	M (5m)	-
Special Lengths	X06 (6m) ~ X10 (10m)	-
	X11 (11m) ~ X15 (15m)	-
	X16 (16m) ~ X20 (20m)	-
	R01 (1m) ~ R03 (3m)	-
Robot Cable	R04 (4m) ~ R05 (5m)	-
	R06 (6m) ~ R10 (10m)	-
	R11 (11m) ~ R15 (15m)	-
	R16 (16m) ~ R20 (20m)	-

* See page A-39 for cables for maintenance.

Actuator Specifications

Item	Description
Drive System	Ball screw ϕ 10mm C10 grade
Positioning Repeatability	\pm 0.02mm
Lost Motion	0.1mm or less
Base	Material: Aluminum (white alumite treated)
Allowable Static Moment	Ma: 38.3N-m Mb: 54.7N-m Mc: 81.0N-m
Allowable Dynamic Moment (*)	Ma: 8.9N-m Mb: 12.7N-m Mc: 18.6N-m
Overhang Load Length	Ma direction: 220mm or less; Mb, Mc directions: 220mm or less
Grease Type	Low dust generation grease (both ball screw and guide)
Cleanliness	Class 10 (0.1 μ m)
Ambient Operating Temp./Humidity	0~40°C, 85% RH or less (non-condensing)

(*) Based on a 5,000km service life.

Directions of Allowable Load Moments

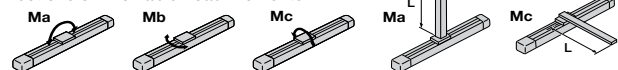

Overhang Load Length

Dimensions

CAD drawings can be downloaded from IAI website. www.intelligentactuator.com

For Special Orders P. A-9



- *1 The motor-encoder cable is connected here. See page A-39 for details on cables.
- *2 After homing, the slider moves to the ME; therefore, please watch for any interference with the surrounding objects.
ME: Mechanical end SE: Stroke end
- *3 Reference position for calculating the moment Ma.

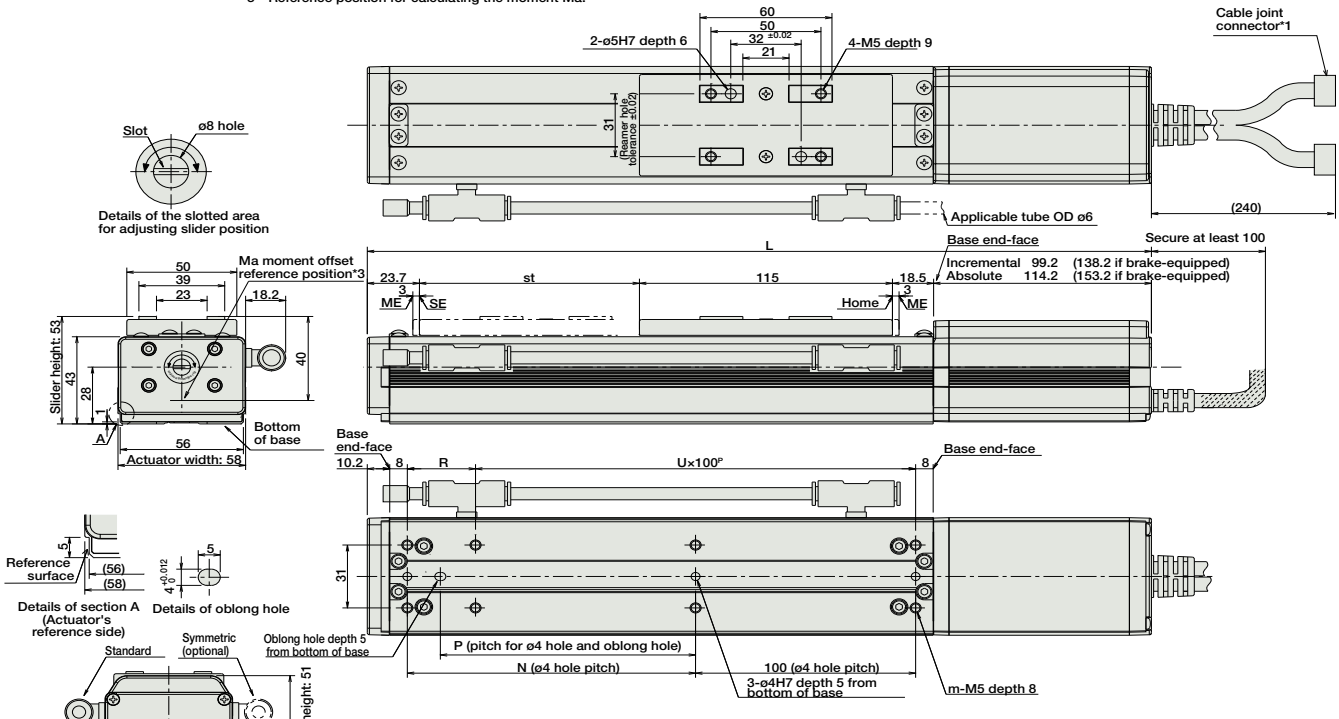

Dimensions and Weight by Stroke

* Adding a brake will increase the actuator's weight by 0.3kg.

Stroke		50	100	150	200	250	300	350	400	450	500	550	600	
L	Incremental	No Brake	306.4	356.4	406.4	456.4	506.4	556.4	606.4	656.4	706.4	756.4	806.4	856.4
		With Brake	345.4	395.4	445.4	495.4	545.4	595.4	645.4	695.4	745.4	795.4	845.4	895.4
	Absolute	No Brake	321.4	371.4	421.4	471.4	521.4	571.4	621.4	671.4	721.4	771.4	821.4	871.4
		With Brake	360.4	410.4	460.4	510.4	560.4	610.4	660.4	710.4	760.4	810.4	860.4	910.4
N		81	131	181	231	281	331	381	431	481	531	581	631	
P		66	116	166	216	266	316	366	416	466	516	566	616	
R		81	31	81	31	81	31	81	31	81	31	81	31	
U		1	2	2	3	3	4	4	5	5	6	6	7	
m		6	8	8	10	10	12	12	14	14	16	16	18	
Weight (kg)		1.4	1.6	1.8	2	2.2	2.4	2.6	2.8	3	3.2	3.4	3.6	

Compatible Controllers

The RCACR series actuators can operate with the controllers below. Select the controller according to your usage.

Name	External View	Model	Description	Max. Positioning Points	Input Voltage	Power Supply Capacity	Standard Price	See Page
Solenoid Valve Type		AMEC-C-30I②-NP-2-1	Easy-to-use controller, even for beginners	3 points	AC100V	2.4A rated	-	→ P477
		ASEP-C-30I②-NP-2-0	Operable with same signal as solenoid valve. Supports both single and double solenoid types. No homing necessary with simple absolute type.					
Splash-Proof Solenoid Valve Type		ASEP-CW-30I②-NP-2-0						→ P487
Positioner Type		ACON-C-30I②-NP-2-0	Positioning is possible for up to 512 points	512 points	DC24V	(Standard) 1.3A rated 4.4A max.	-	→ P535
Safety-Compliant Positioner Type		ACON-CG-30I②-NP-2-0						
Pulse Train Input Type (Differential Line Driver)		ACON-PL-30I②-NP-2-0	Pulse train input type with differential line driver support	(-)	DC24V	(Power-saving) 1.3A rated 2.2A max.	-	→ P535
Pulse Train Input Type (Open Collector)		ACON-PO-30I②-NP-2-0	Pulse train input type with open collector support					
Serial Communication Type		ACON-SE-30I②-N-0-0	Dedicated to serial communication	64 points				
Field Network Type		RACON-30②	Dedicated to field network	768 points				→ P503
Program Control Type		ASEL-C-1-30①②-NP-2-0	Programmed operation is possible. Operation is possible on up to 2 axes	1500 points				→ P567

* This is for the single-axis ASEL.
 * ① is a placeholder for the encoder type (I: incremental / A: absolute).
 * ② is a placeholder for the code *LA* if the power-saving option is specified.

- Slider Type
- Mini
- Standard
- Controllers Integrated
- Rod Type
- Mini
- Standard
- Controllers Integrated
- Table/Arm/Flat Type
- Mini
- Standard
- Gripper/Rotary Type
- Linear Servo Type
- Cleanroom Type
- Splash Proof
- Controllers
- PMEC /AMEC
- PSEP /ASEP
- ROBO NET
- ERC2
- PCON
- ACON
- SCON
- PSEL
- ASEL
- SSEL
- XSEL
- Pulse Motor
- Servo Motor (24V)
- Servo Motor (200V)
- Linear Servo Motor