

# RCP2-GR3LS

ROBO Cylinder 3-Finger Gripper Lever Type 62mm Width Pulse Motor

■ Configuration: **RCP2-GR3LS-I-28P-30-19**

Series	Type	Encoder	Motor	Deceleration Ratio	Stroke	Compatible Controllers	Cable Length	Option
I: Incremental * The Simple absolute encoder is also considered type "I".	28P: 28 □ size Pulse motor	30: 1/30 deceleration ratio	19: 19 degrees	P1: PCON RPCON PSEL P3: PMEC PSEP	N: None P: 1m S: 3m M: 5m X□□: Custom R□□: Robot cable	FB: Flange bracket SB: Shaft bracket		

\* See page Pre-35 for an explanation of the naming convention.



Technical References P. A-5

- POINT**  
Notes on Selection
- (1) The maximum opening/closing speed indicates the operating speed on one side. The relative operating speed is twice this value.
  - (2) The maximum gripping force is the sum of the gripping forces of all fingers with gripping point distance of 10mm and no overhang distance. For the actual transportable work piece weight, see explanation on the right, or page A-77.
  - (3) The rated acceleration while moving is 0.3G.

### ■ Gripping Force vs. Current Limit Lever Type (GR3LS/GR3LM)

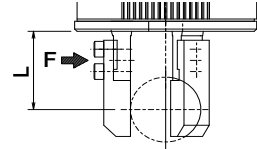

\* Please note that, when gripping (pushing), the speed is fixed at 5 degrees/s.

\* The values in the graph below are gripping forces at 10mm gripping point. The actual gripping force decreases inversely proportional to the distance from the opening/closing point. You can calculate the actual gripping force by the following equation.  
Actual gripping force (type S) =  $P \times 24 / (L + 14)$   
Actual gripping force (type M) =  $P \times 28.5 / (L + 18.5)$   
P = Gripping force on graph  
L = Distance from finger mounting surface to the gripping point.

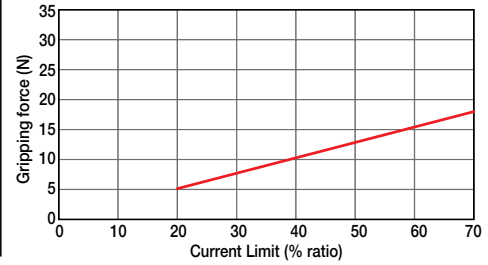

Actuator Specifications			
<b>■ Lead and Load Capacity</b>			
Model	Deceleration Ratio	Max. Gripping Force (N)	Stroke (deg)
RCP2-GR3LS-I-28P-30-19-①-②-③	30	18	19
Legend: ① Compatible controllers ② Cable length ③ Options			
<b>■ Stroke and Maxi. Opening/Closing Speed</b>			
Stroke	19 (deg)		
Deceleration Ratio	30	200	
(Unit: degrees/s)			

Stroke List	
Stroke (deg)	Standard Price
10	-

② Cable List		
Type	Cable Symbol	Standard Price
Standard Type	P (1m)	-
	S (3m)	-
	M (5m)	-
Special Lengths	X06 (6m) ~ X10 (10m)	-
	X11 (11m) ~ X15 (15m)	-
	X16 (16m) ~ X20 (20m)	-
Robot Cable	R01 (1m) ~ R03 (3m)	-
	R04 (4m) ~ R05 (5m)	-
	R06 (6m) ~ R10 (10m)	-
	R11 (11m) ~ R15 (15m)	-
	R16 (16m) ~ R20 (20m)	-

\* See page A-39 for cables for maintenance.

③ Option List			
Name	Option Code	See Page	Standard Price
Flange bracket	FB	→ A-26	-
Shaft bracket	SB	→ A-36	-

Actuator Specifications	
Item	Description
Drive System	Worm gear + worm wheel gear
Positioning Repeatability	±0.01 degrees
Backlash	1 degree or less per side (constantly pressed out by a spring)
Lost Motion	0.15 degrees or less per side
Weight	0.6kg
Ambient Operating Temp./Humidity	0~40°C, 85% RH or less (non-condensing)

Dimensions

CAD drawings can be downloaded from IAI website. [www.intelligentactuator.com](http://www.intelligentactuator.com)



- \* When homing, the actuator swings 1 degree past the home position before returning. Therefore, please watch for any interference with the surrounding objects.
- \*1 The motor-encoder cable is connected here. See page A-39 for details on cables.

For Special Orders P. A-9

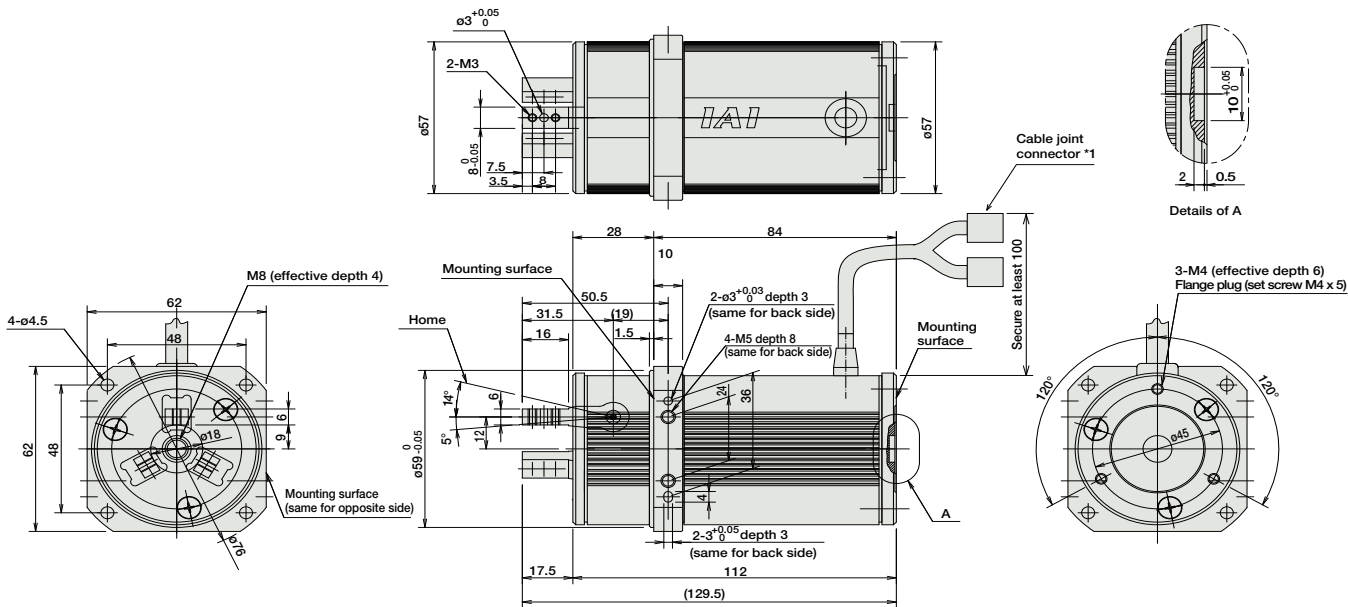

Weight (kg) 0.6

① Compatible Controllers

The RCP2 series actuators can operate with the controllers below. Select the controller according to your usage.

Name	External View	Model	Description	Max. Positioning Points	Input Voltage	Power Supply Capacity	Standard Price	See Page
Solenoid Valve Type		PMEC-C-28PI-NP-2-①	Easy-to-use controller, even for beginners	3 points	AC100V AC200V	See P481	-	→ P477
		PSEP-C-28PI-NP-2-0	Operable with same signal as solenoid valve. Supports both single and double solenoid types. No homing necessary with simple absolute type.				-	→ P487
Splash-Proof Solenoid Valve Type		PSEP-CW-28PI-NP-2-0					-	
Positioner Type		PCON-C-28PI-NP-2-0	Positioning is possible for up to 512 points	512 points	DC24V	2A max.	-	→ P525
Safety-Compliant Positioner Type		PCON-CG-28PI-NP-2-0					-	
Pulse Train Input Type (Differential Line Driver)		PCON-PL-28PI-NP-2-0	Pulse train input type with differential line driver support	(-)	DC24V	2A max.	-	→ P525
Pulse Train Input Type (Open Collector)		PCON-PO-28PI-NP-2-0	Pulse train input type with open collector support				-	
Serial Communication Type		PCON-SE-28PI-N-0-0	Dedicated to serial communication	64 points			-	
Field Network Type		RPCON-28P	Dedicated to field network	768 points			-	→ P503
Program Control Type		PSEL-C-1-28PI-NP-2-0	Programmed operation is possible. Operation is possible on up to 2 axes	1500 points			-	→ P557

\* This is for the single-axis PSEL.

\* ① is a placeholder for the power supply voltage (1: 100V, 2: 100~240V).

- Slider Type
- Mini
- Standard
- Controllers Integrated
- Rod Type
- Mini
- Standard
- Controllers Integrated
- Table/Arm/Flat Type
- Mini
- Standard
- Controllers Integrated
- Table/Arm/Flat Type
- Mini
- Standard
- Gripper/Rotary Type
- Linear Servo Type
- Cleanroom Type
- Splash-Proof
- Controllers
- PMEC/AMEC
- PSEP/ASEP
- ROBO NET
- ERC2
- PCON
- ACON
- SCON
- PSEL
- ASEL
- SSEL
- XSEL
- Pulse Motor
- Servo Motor (24V)
- Servo Motor (200V)
- Linear Servo Motor