

RCA2-TA4R

ROBO Cylinder Mini Table Type Side-Mounted Motor 40mm Width 24V Servo Motor
Ball Screw

■ Configuration: **RCA2** — **TA4R** — **I** — **10** — — — — —

Series	Type	Encoder	Motor	Lead	Stroke	Compatible Controllers	Cable Length	Option
RCA2	TA4R	I: Incremental * The simple absolute encoder is also considered type "I".	10: 10W Servo motor	6 : 6mm 4 : 4mm 2 : 2mm	20: 20mm ↓ 100: 100mm (10mm pitch increments)	A1 : ACON RACON ASEL A3 : AMEC ASEP	N : None P : 1m S : 3m M : 5m X <input type="checkbox"/> : Custom	See Options below * Be sure to specify which side the motor is to be mounted (ML/MR).

* See page Pre-35 for an explanation of the naming convention.

Power-saving



Pictured: TA3R with left-mounted motor (ML).

Technical References P. A-5

POINT Notes on Selection

(1) The load capacity is based on operation at an acceleration of 0.3G (0.2G for the 2mm-lead model, or when used vertically). 0.3G (0.2G for 2mm lead) is the upper limit of the acceleration.

Actuator Specifications

■ Lead and Load Capacity

Model	Motor Output (W)	Feed Screw	Lead (mm)	Max. Load Capacity		Rated Thrust (N)	Positioning Repeatability (mm)	Stroke (mm)
				Horizontal (kg)	Vertical (kg)			
RCA2-TA4R-I-10-6-①-②-③-④	10	Ball screw	6	1	0.5	28	±0.02	20~100 (10mm increments)
RCA2-TA4R-I-10-4-①-②-③-④			4	2	1	43		
RCA2-TA4R-I-10-2-①-②-③-④			2	3	1.5	85		

Legend: ① Stroke ② Compatible controller ③ Cable length ④ Options

■ Stroke and Maximum Speed

Lead	Stroke	
	6	20 ~ 100 (10mm increments)
Ball screw	6	300
	4	200
	2	100

(Unit: mm/s)

① Stroke List

Stroke (mm)	Standard Price
20	-
30	-
40	-
50	-
60	-
70	-
80	-
90	-
100	-

③ Cable List

Type	Cable Symbol	Standard Price
Standard Type (Robot Cables)	P (1m)	-
	S (3m)	-
	M (5m)	-
Special Lengths	X06 (6m) ~ X10 (10m)	-
	X11 (11m) ~ X15 (15m)	-
	X16 (16m) ~ X20 (20m)	-
		-

* The RCA2 comes standard with a robot cable.

* See page A-39 for cables for maintenance.

④ Option List

Name	Option Code	See Page	Standard Price
Brake	B	→ A-25	-
Cable exit direction (Top)	CJT	→ A-25	-
Cable exit direction (Outside)	CJO		
Cable exit direction (Bottom)	CJB		
Power-saving	LA	→ A-32	-
Left-mounted Motor (Standard)	ML	→ A-33	-
Right-mounted motor	MR	→ A-33	-
Reversed-home	NM	→ A-33	-

Actuator Specifications

Item	Description
Drive System	Ball screw ø6mm C10 grade
Lost Motion	0.1mm or less
Base	Material: Aluminum (white alumite treated)
Allowable Dynamic Moment (Note)	Ma: 4.2 N·m Mb: 6 N·m Mc: 8.2 N·m
Ambient Operating Temp./Humidity	0~40°C, 85% RH or less (non-condensing)

(Note) Based on a 5,000km service life.

Dimensions

CAD drawings can be downloaded from IAI website. www.intelligentactuator.com

For Special Order P. A-9



* The diagram below shows a left-mounted motor model.

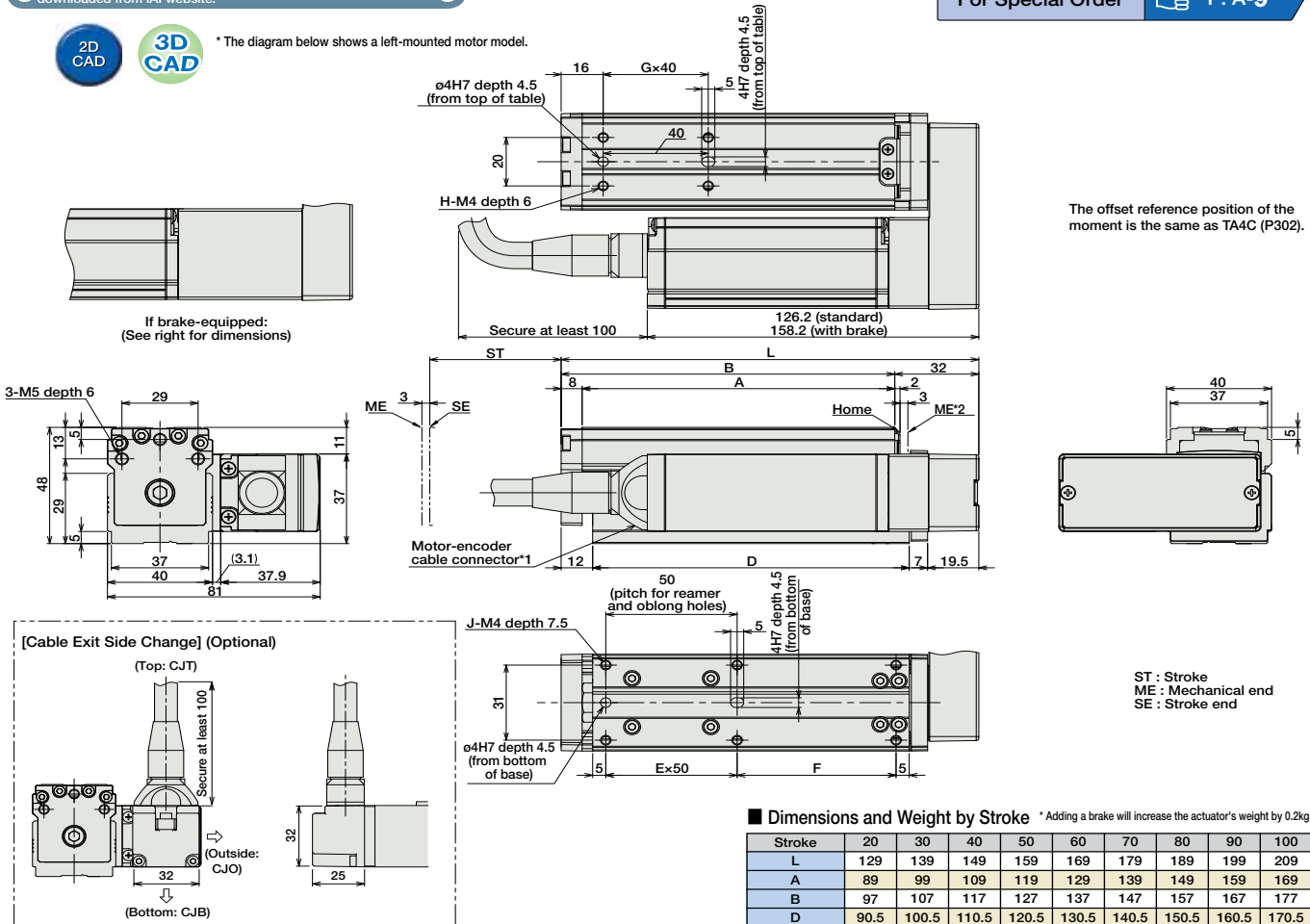

The offset reference position of the moment is the same as TA4C (P302).

ST : Stroke
ME : Mechanical end
SE : Stroke end

■ Dimensions and Weight by Stroke * Adding a brake will increase the actuator's weight by 0.2kg.

Stroke	20	30	40	50	60	70	80	90	100
L	129	139	149	159	169	179	189	199	209
A	89	99	109	119	129	139	149	159	169
B	97	107	117	127	137	147	157	167	177
D	90.5	100.5	110.5	120.5	130.5	140.5	150.5	160.5	170.5
E	1	1	1	1	2	2	2	2	2
F	30.5	40.5	50.5	60.5	20.5	30.5	40.5	50.5	60.5
G	1	1	1	1	2	2	2	2	2
H	4	4	4	4	6	6	6	6	6
J	6	6	6	6	8	8	8	8	8
Weight (kg)	0.8	0.9	0.9	0.9	1.0	1.0	1.0	1.1	1.1

*1 The motor-encoder cable is connected directly to the motor cover of the actuator. See page A-39 for details on cables.
*2 When homing, the slider moves to the mechanical end; therefore, please watch for any interference with the surrounding objects.

② Compatible Controllers

The RCA2 series actuators can operate with the controllers below. Select the controller according to your usage.

Name	External View	Model	Description	Max. Positioning Points	Input Voltage	Power Supply Capacity	Standard Price	See Page
Solenoid Valve Type		AMEC-C-10①-NP-2-1	Easy-to-use controller, even for beginners	3 points	AC100V	2.4A rated	-	→ P477
		ASEP-C-10①-NP-2-0	Operable with same signal as solenoid valve. Supports both single and double solenoid types. No homing necessary with simple absolute type.					
Splash-Proof Solenoid Valve Type		ASEP-CW-10①-NP-2-0						→ P487
Positioner Type		ACON-C-10①-NP-2-0	Positioning is possible for up to 512 points	512 points	DC24V	(Standard) 1.3A rated 4.4A max.	-	
Safety-Compliant Positioner Type		ACON-CG-10①-NP-2-0						
Pulse Train Input Type (Differential Line Driver)		ACON-PL-10①-NP-2-0	Pulse train input type with differential line driver support	(-)	DC24V	(Power-saving) 1.3A rated 2.5A max.	-	→ P535
Pulse Train Input Type (Open Collector)		ACON-PO-10①-NP-2-0	Pulse train input type with open collector support					
Serial Communication Type		ACON-SE-10①-N-0-0	Dedicated to serial communication	64 points				
Field Network Type		RACON-10①	Dedicated to field network	768 points				→ P503
Program Control Type		ASEL-C-1-10①-NP-2-0	Programmed operation is possible. Operation is possible on up to 2 axes	1500 points				→ P567

* This is for the single-axis ASEL.
* ① is a placeholder for the code "LA", if the power-saving option is specified.

- Slider Type
- Mini
- Standard
- Controllers Integrated
- Rod Type
- Mini
- Standard
- Controllers Integrated
- Table/Arm/Flat Type
- Mini
- Standard
- Controllers Integrated
- Gripper/Rotary Type
- Linear Servo Type
- Cleanroom Type
- Splash Proof
- Controllers
- PMEC/AMEC
- PSEP/ASEP
- ROBO NET
- ERC2
- PCON
- ACON
- SCON
- PSEL
- ASEL
- SSEL
- XSEL
- Pulse Motor
- Servo Motor (24V)
- Servo Motor (200V)
- Linear Servo Motor