

RCA2-TA5C

ROBO Cylinder Table Type Motor Unit Coupled 55mm Width 24V Servo Motor Ball Screw

■ Configuration: **RCA2** — **TA5C** — **I** — **20** — — — — —

Series — Type — Encoder — Motor — Lead — Stroke — Compatible Controllers — Cable Length — Option

I: Incremental
* The simple absolute encoder is also considered type "I".

20: 20W Servo motor

10 : 10mm
5 : 5mm
2.5 : 2.5mm

25: 25mm
100: 100mm (25mm pitch increments)

A1: ACON
RACON
ASEL
A3: AMEC
ASEP

N : None
P : 1m
S : 3m
M : 5m
X : Custom

See Options below

* See page Pre-35 for an explanation of the naming convention.

Power-saving

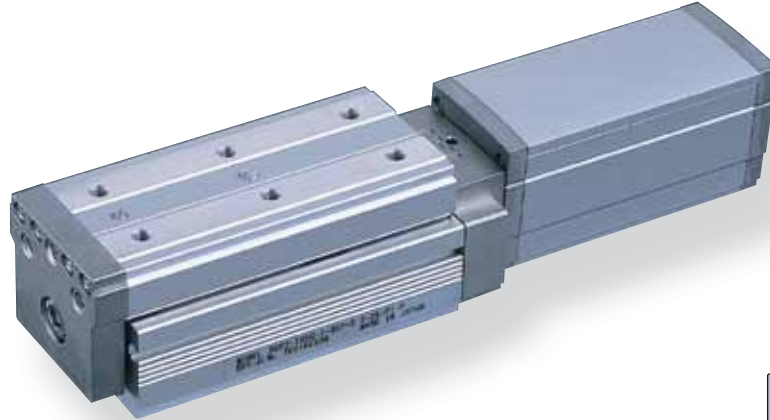

Technical References P. A-5

POINT
Notes on Selection

- Please note that the maximum speed is different when used horizontally versus vertically.
- The load capacity is based on operation at an acceleration of 0.3G (0.2G for the 2.5mm-lead model, or when used vertically). This is the upper limit of the acceleration.

Actuator Specifications

■ Lead and Load Capacity

Model	Motor Output (W)	Lead (mm)	Max. Load Capacity		Rated Thrust (N)	Stroke (mm)
			Horizontal (kg)	Vertical (kg)		
RCA2-TA5C-I-20-10-①-②-③-④	20	10	2	1	34	25~100 (25mm increments)
RCA2-TA5C-I-20-5-①-②-③-④		5	3.5	2	68	
RCA2-TA5C-I-20-2.5-①-②-③-④		2.5	5	3	137	

■ Stroke and Maximum Speed

Stroke Lead	25 ~ 100 (25mm increments)	
	10	465 <400>
5	250	
2.5	125	

Legend: ① Stroke ② Compatible controller ③ Cable length ④ Options

* The values enclosed in "<" ">" apply to vertical usage. (Unit: mm/s)

① Stroke List

Stroke (mm)	Standard Price
25	-
50	-
75	-
100	-

③ Cable List

Type	Cable Symbol	Standard Price
Standard Type (Robot Cables)	P (1m)	-
	S (3m)	-
	M (5m)	-
Special Lengths	X06 (6m) ~ X10 (10m)	-
	X11 (11m) ~ X15 (15m)	-
	X16 (16m) ~ X20 (20m)	-
		-

* The RCA2 comes standard with a robot cable.
* See page A-39 for cables for maintenance.

④ Options List

Name	Option Code	Standard Price	Standard Price
Brake	B	→ A-25	-
Cable exit direction (Top)	CJT	→ A-25	-
Cable exit direction (Right)	CJR	→ A-25	-
Cable exit direction (Left)	CJL	→ A-25	-
Cable exit direction (Bottom)	CJB	→ A-25	-
Power-saving	LA	→ A-32	-
Reversed-home	NM	→ A-33	-

Actuator Specifications

Item	Description
Drive System	Ball screw ø8mm C10 grade
Positioning Repeatability	±0.02mm
Lost Motion	0.1mm or less
Base	Material: Aluminum (special alumite treated)
Allowable Static Moment	Ma: 25.5 N·m Mb: 36.5 N·m Mc: 56.1 N·m
Allowable Dynamic Moment (*)	Ma: 6.57 N·m Mb: 9.32 N·m Mc: 14.32 N·m
Overhang Load Length	Within the load moment range
Ambient Operating Temp./Humidity	0~40°C, 85% RH or less (non-condensing)

(*) Based on a 5,000km service life.

Directions of Allowable Load Moments

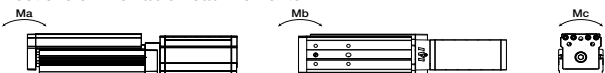

Dimensions

CAD drawings can be downloaded from IAI website. www.intelligentactuator.com

For Special Order  P. A-9

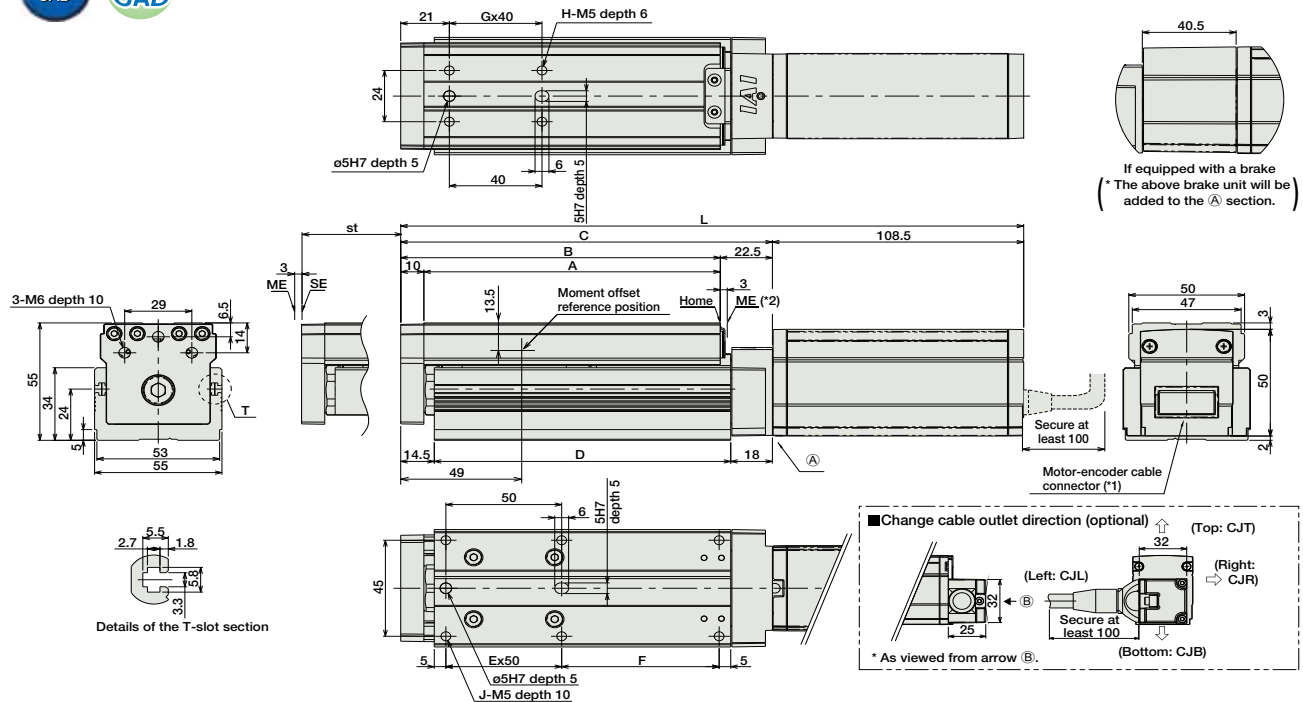











■ Dimensions and Weight by Stroke * Adding a brake will increase the actuator's weight by 0.3kg.

Stroke	L	Stroke			
		25	50	75	100
L	No brake	244	269	294	319
	Brake-equipped	284.5	309.5	334.5	359.5
A		103	128	153	178
B		113	138	163	188
C		135.5	160.5	185.5	210.5
D		103	128	153	178
E		1	1	2	2
F		43	68	43	68
G		1	1	2	2
H		4	4	6	6
J		6	6	8	8
Weight (kg)		1.2	1.4	1.5	1.7

(*1) The motor-encoder cable is connected directly to the motor cover of the actuator. See page A-39 for details on cables.
 (*2) After homing, the slider moves to the ME; therefore, please watch for any interference with the surrounding objects.
 ME: Mechanical end
 SE: Stroke end

② Compatible Controllers

The RCA2 series actuators can operate with the controllers below. Select the controller according to your usage.

Name	External View	Model	Description	Max. Positioning Points	Input Voltage	Power Supply Capacity	Standard Price	See Page					
Solenoid Valve Type		AMEC-C-20SI①-NP-2-1	Easy-to-use controller, even for beginners	3 points	AC100V	2.4A rated	-	→ P477					
		ASEP-C-20SI①-NP-2-0	Operable with same signal as solenoid valve. Supports both single and double solenoid types. No homing necessary with simple absolute type.						→ P487				
Splash-Proof Solenoid Valve Type		ASEP-CW-20SI①-NP-2-0											
Positioner Type		ACON-C-20SI①-NP-2-0	Positioning is possible for up to 512 points	512 points				DC24V	(Standard) 1.3A rated 4.4A max. (Power-saving) 1.3A rated 2.5A max.	-			
Safety-Compliant Positioner Type		ACON-CG-20SI①-NP-2-0											
Pulse Train Input Type (Differential Line Driver)		ACON-PL-20SI①-NP-2-0	Pulse train input type with differential line driver support	(-)									→ P535
Pulse Train Input Type (Open Collector)		ACON-PO-20SI①-NP-2-0	Pulse train input type with open collector support										
Serial Communication Type		ACON-SE-20SI①-N-0-0	Dedicated to serial communication	64 points									
Field Network Type		RACON-20S①	Dedicated to field network	768 points									
Program Control Type		ASEL-C-1-20SI①-NP-2-0	Programmed operation is possible. Operation is possible on up to 2 axes	1500 points							→ P567		

* This is for the single-axis ASEL.
 * ① is a placeholder for the code "LA", if the power-saving option is specified.