

# RCS2-RA4R

ROBO Cylinder Rod Type ø37mm Diameter 200V Servo Motor  
Side-Mounted Motor

■ Configuration: **RCS2** — **RA4R** —  —  —  —  —  —  —  —  —

Series — Type — Encoder — Motor — Lead — Stroke — Compatible Controllers — Cable Length — Option

I : Incremental  
A : Absolute

20 : 20W Servo Motor  
30 : 30W Servo Motor

12 : 12mm  
6 : 6mm  
3 : 3mm

50 : 50mm  
300 : 300mm (50mm pitch increments)

T1 : XSEL-J/K  
T2 : SCON  
SSEL  
XSEL-P/Q

N : None  
P : 1m  
S : 3m  
M : 5m  
X  : Custom  
R  : Robot cable

See Options below

\* See page Pre-35 for an explanation of the naming convention.

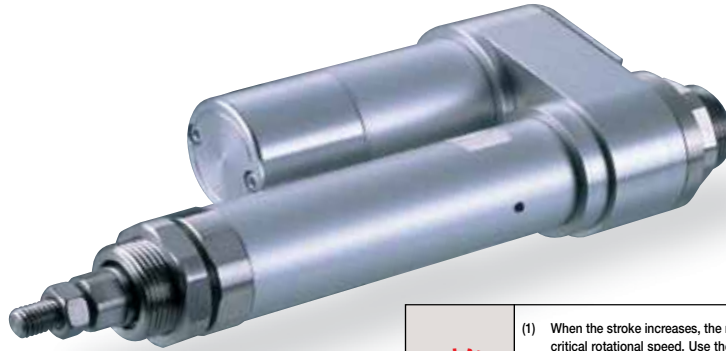

Technical References P. A-5

- POINT**  
Notes on Selection
- When the stroke increases, the maximum speed will drop to prevent the ball screw from reaching the critical rotational speed. Use the actuator specification table below to check the maximum speed at the stroke you desire.
  - The load capacity is based on operation at an acceleration of 0.3G (0.2G for the 3mm-lead model). This is the upper limit of the acceleration.
  - The values for the horizontal load capacity assume the use of an external guide, so that there is no external force from any direction other than the forward/backward direction of the rod.

### Actuator Specifications

#### Lead and Load Capacity

Model	Motor Output (W)	Lead (mm)	Max. Load Capacity		Rated Thrust (N)	Stroke (mm)
			Horizontal (kg)	Vertical (kg)		
RCS2-RA4R-①-20-12-②-③-④-⑤	20	12	3.0	1.0	18.9	50 ~ 300 (50mm increments)
RCS2-RA4R-①-20-6-②-③-④-⑤		6	6.0	2.0	37.7	
RCS2-RA4R-①-20-3-②-③-④-⑤		3	12.0	4.0	75.4	
RCS2-RA4R-①-30-12-②-③-④-⑤	30	12	4.0	1.5	28.3	
RCS2-RA4R-①-30-6-②-③-④-⑤		6	9.0	3.0	56.6	
RCS2-RA4R-①-30-3-②-③-④-⑤		3	18.0	6.5	113.1	

Legend: ① Encoder ② Stroke ③ Compatible controller ④ Cable length ⑤ Options

#### Stroke and Maximum Speed

Stroke Lead	50 ~ 300 (50mm increments)	
	Stroke	Maximum Speed
12	600	
6	300	
3	150	

(Unit: mm/s)

#### Encoder & Stroke List

② Stroke (mm)	Standard Price			
	① Encoder			
	Incremental		Absolute	
	Motor Output (W)		Motor Output (W)	
	20W	30W	20W	30W
50	-	-	-	-
100	-	-	-	-
150	-	-	-	-
200	-	-	-	-
250	-	-	-	-
300	-	-	-	-

#### ④ Cable List

Type	Cable Symbol	Standard Price
Standard	P (1m)	-
	S (3m)	-
	M (5m)	-
Special Lengths	X06 (6m) ~ X10 (10m)	-
	X11 (11m) ~ X15 (15m)	-
	X16 (16m) ~ X20 (20m)	-
Robot Cable	R01 (1m) ~ R03 (3m)	-
	R04 (4m) ~ R05 (5m)	-
	R06 (6m) ~ R10 (10m)	-
	R11 (11m) ~ R15 (15m)	-
	R16 (16m) ~ R20 (20m)	-

\* See page A-39 for cables for maintenance.

#### ⑤ Option List

Name	Option Code	See Page	Standard Price
Brake	B	→ A-25	-
Foot bracket	FT	→ A-29	-
Flange bracket (front)	FL	→ A-27	-
Flange bracket (back)	FLR	→ A-28	-
Home sensor	HS	→ A-32	-
Knuckle joint	NJ	→ A-34	-
Reversed-home	NM	→ A-33	-
Clevis Bracket	QR	→ A-34	-
Back-mounting plate	RP	→ A-35	-
Trunnion bracket (front)	TRF	→ A-38	-

\* The home sensor (HS) cannot be used on the reversed-home models.

#### Actuator Specifications

Item	Description
Drive System	Ball screw ø10mm C10 grade
Positioning Repeatability	±0.02mm
Lost Motion	0.1mm or less
Base	Material: Aluminum (white alumite treated)
Rod Diameter	ø20mm
Non-rotating accuracy of rod	±1.0 deg
Ambient Operating Temp./Humidity	0 ~ 40°C, 85% RH or less (non-condensing)

Dimensions

CAD drawings can be downloaded from IAI website. [www.intelligentactuator.com](http://www.intelligentactuator.com)

For Special Orders P. A-9



- \*1. The motor-encoder cable is connected here. See page A-39 for details on cables.
- \*2. When homing, the rod moves to the ME; therefore, please watch for any interference with the surrounding objects.  
ME: Mechanical end SE: Stroke end

\*3. The orientation of the bolt will vary depending on the product.

[No Brake]

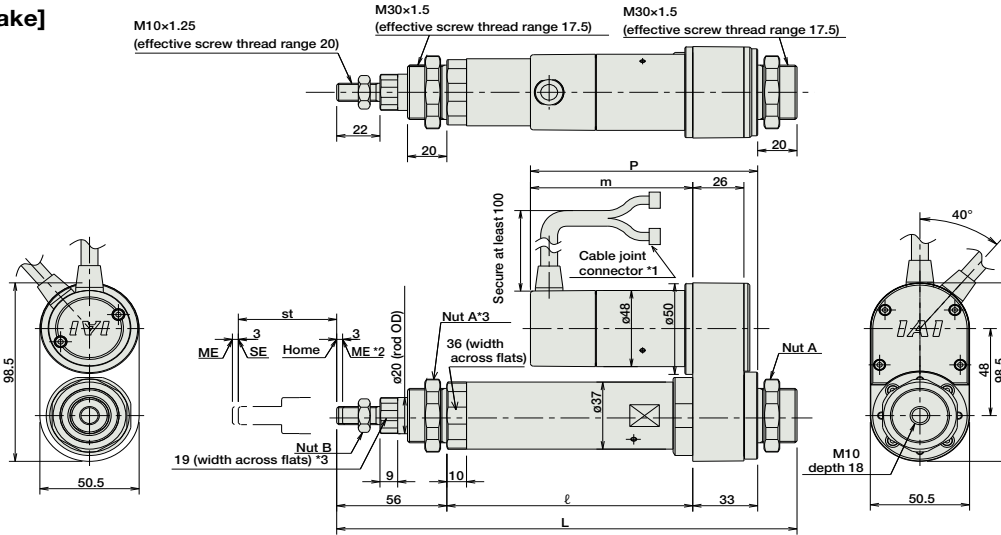

[Brake-Equipped]

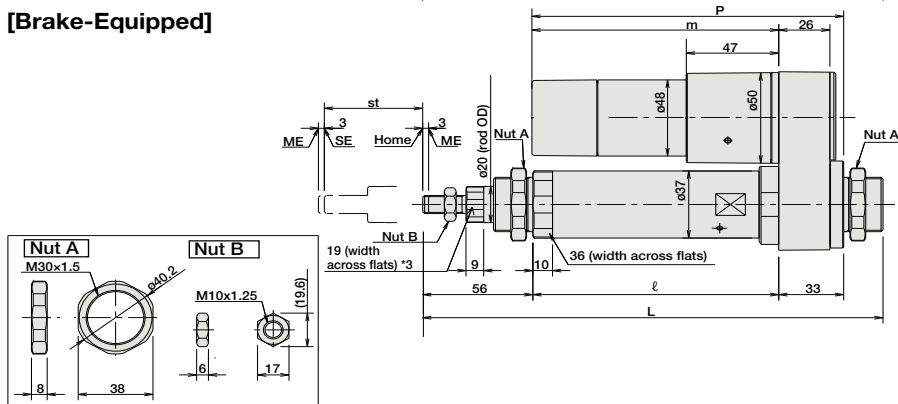

■ Dimensions/Weight by Stroke

RCS2-RA4R (without brake)

Stroke	50	100	150	200	250	300
L	20W	234	284	334	384	434
	30W	234	284	334	384	434
l	20W	125	175	225	275	325
	30W	125	175	225	275	325
m	20W	80.5				
	30W	95.5				
P	20W	113.5				
	30W	128.5				
Weight (kg)	20W	1.2	1.4	1.5	1.7	1.8
	30W	1.2	1.4	1.5	1.7	1.8

RCS2-RA4R (with brake)

Stroke	50	100	150	200	250	300
L	20W	234	284	334	384	434
	30W	234	284	334	384	434
l	20W	125	175	225	275	325
	30W	125	175	225	275	325
m	20W	123.5				
	30W	138.5				
P	20W	156.5				
	30W	171.5				
Weight (kg)	20W	1.4	1.6	1.7	1.9	2.0
	30W	1.4	1.6	1.7	1.9	2.0

③ Compatible Controllers

The RCS2 series actuators can operate with the controllers below. Select the controller according to your usage.

Name	External View	Model	Description	Max. Positioning Points	Input Voltage	Power Supply Capacity	Standard Price	See Page
Positioner Mode		SCON-C-20 ①-NP-2-② SCON-C-30D ①-NP-2-②	Positioning is possible for up to 512 points	512 points	Single-Phase AC 100V Single-Phase AC 200V Three-phase AC 200V (XSEL-P/Q only)	360VA max.  * When operating a 150W single-axis model	-	→ P547
Solenoid Valve Mode			Operable with same controls as solenoid valve.	7 points				
Serial Communication Type			Dedicated to serial communication	64 points				
Pulse Train Input Control Type			Dedicated to Pulse Train Input	(-)				
Program Control 1-2 Axes Type		SSEL-C-1-20 ①-NP-2-② SSEL-C-1-30D ①-NP-2-②	Programmed operation is possible Operation is possible on up to 2 axes	20000 points			-	→ P577
Program Control 1-6 Axes Type			Programmed operation is possible Operation is possible on up to 6 axes	20000 points				

\* For SSEL and XSEL, only applicable to the single-axis model.  
 \* ① is a placeholder for the encoder type (I: incremental / A: absolute).  
 \* ② is a placeholder for the power supply voltage (1: 100V, 2: single-phase 200V).  
 \* ③ is a placeholder for the XSEL type name ("J", "K", "P", or "Q").  
 \* ④ is a placeholder for the power supply voltage (1: 100V, 2: single-phase 200V, or 3: three-phase 200V).