

# RCA-SA6R

ROBO Cylinder Slider Type 58mm Width 24V Servo Motor Side-Mounted Motor

■ Configuration: **RCA** — **SA6R** —  — **30** —  —  —  —  —

Series — Type — Encoder — Motor — Lead — Stroke — Compatible Controllers — Cable Length — Option

I: Incremental      30: 30W Servo motor  
 A: Absolute  
\* Absolute encoder models can only use ASEL.  
 When the actuator is used with the simple absolute encoder, the model is considered an incremental model.

12: 12mm  
 6: 6mm  
 3: 3mm

50: 50mm  
 600: 600mm (50mm pitch increments)

A1: ACON  
 RACON  
 ASEL  
 A3: AMEC  
 ASEP

N: None  
 P: 1m  
 S: 3m  
 M: 5m  
 X : Custom Length  
 R : Robot Cable

See Options below  
\* Be sure to specify which side the motor is to be mounted (ML/MR).

\* See page Pre-35 for explanation of each code that makes up the configuration name.

Power-saving

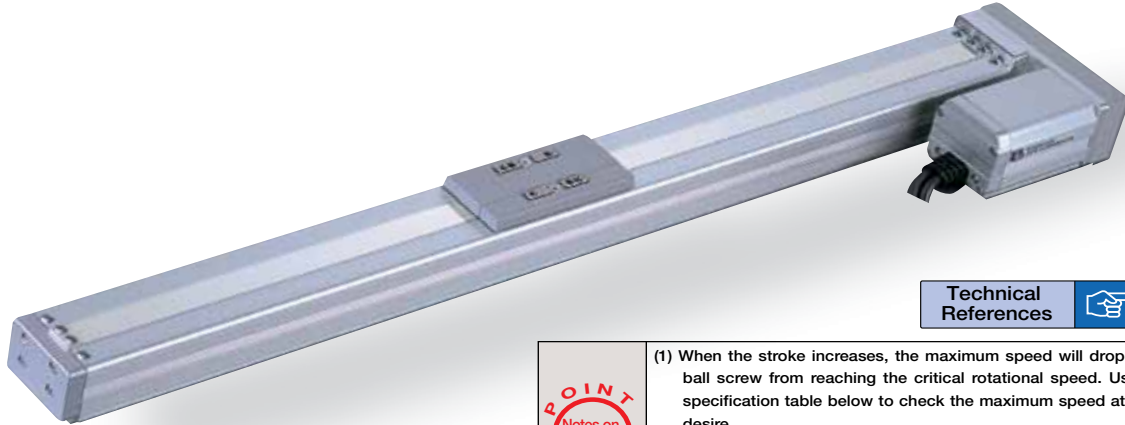

Technical References P. A-5

- POINT**  
Notes on Selection
- (1) When the stroke increases, the maximum speed will drop to prevent the ball screw from reaching the critical rotational speed. Use the actuator specification table below to check the maximum speed at the stroke you desire.
  - (2) The load capacity is based on operation at an acceleration of 0.3G (0.2G for the 3mm-lead model). These values are the upper limits for the acceleration.

Pictured: Left-mounted motor model (ML).

Actuator Specifications

■ Lead and Load Capacity

Model	Motor Output (w)	Lead (mm)	Max. Load Capacity		Rated Thrust (N)	Stroke (mm)
			Horizontal (kg)	Vertical (kg)		
RCA-SA6R-①-30-12-②-③-④-⑤	30	12	6	1.5	24.2	50 ~ 600 (50mm increments)
RCA-SA6R-①-30-6-②-③-④-⑤		6	12	3	48.4	
RCA-SA6R-①-30-3-②-③-④-⑤		3	18	6	96.8	

■ Stroke and Maximum Speed

Stroke Lead	50 ~ 450 (50mm increments)	500 (mm)	550 (mm)	600 (mm)
	12	800	760	640
6	400	380	320	270
3	200	190	160	135

Legend ① Encoder ② Stroke ③ Compatible controller ④ Cable length ⑤ Options (Unit: mm/s)

Encoder & Stroke List

② Stroke (mm)	Standard Price	
	① Encoder Type	
	Incremental	Absolute
50	I	A
100	-	-
150	-	-
200	-	-
250	-	-
300	-	-
350	-	-
400	-	-
450	-	-
500	-	-
550	-	-
600	-	-

④ Cable List

Type	Cable Symbol	Standard Price
Standard	P (1m)	—
	S (3m)	—
	M (5m)	—
Special Lengths	X06 (6m) ~ X10 (10m)	—
	X11 (11m) ~ X15 (15m)	—
	X16 (16m) ~ X20 (20m)	—
	R01 (1m) ~ R03 (3m)	—
Robot Cable	R04 (4m) ~ R05 (5m)	—
	R06 (6m) ~ R10 (10m)	—
	R11 (11m) ~ R15 (15m)	—
	R16 (16m) ~ R20 (20m)	—

\* See page A-39 for cables for maintenance.

⑤ Option List

Name	Option Code	See Page	Standard Price
Brake	B	→ A-25	—
Home sensor	HS	→ A-32	—
Power-saving	LA	→ A-32	—
Reversed-home	NM	→ A-33	—
Left-Mounted Motor (Standard)	ML	→ A-33	—
Right-Mounted Motor	MR	→ A-33	—
Slider Roller	SR	→ A-36	—

Actuator Specifications

Item	Description
Drive System	Ball screw ø10mm C10 grade
Positioning Repeatability	±0.02mm
Lost Motion	0.1mm or less
Base	Material: Aluminum (white alumite treated)
Allowable Static Moment	Ma: 38.3N·m Mb: 54.7N·m Mc: 81.0N·m
Allowable Dynamic Moment (*)	Ma: 8.9 N·m Mb: 12.7 N·m Mc: 18.6 N·m
Overhang Load Length	Ma direction: 220mm or less Mb-Mc direction: 220mm or less
Ambient Operating Temp./Humidity	0~40°C, 85%RH or less (Non-condensing)

(\*) Based on 5,000km travel life.

Directions of Allowable Load Moments

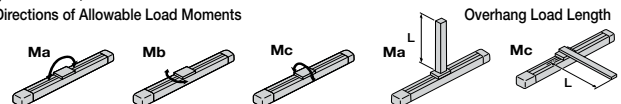

Dimensions

CAD drawings can be downloaded from IAI website. [www.intelligentactuator.com](http://www.intelligentactuator.com)

For Special Orders P. A-9

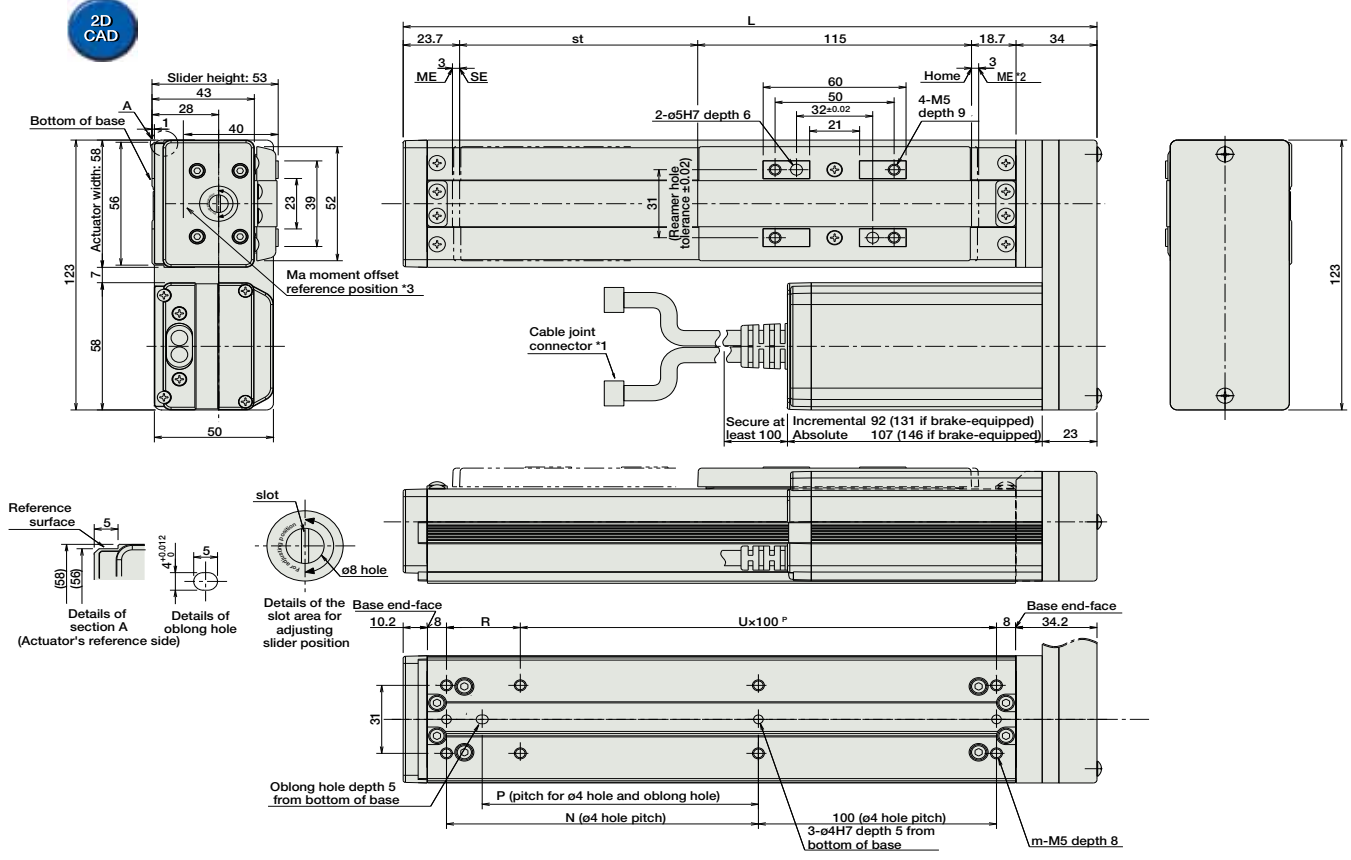

\*1 A motor-encoder cable is connected here. See page A-39 for details on cables.  
 \*2 When homing, the slider moves to the ME; therefore, please watch for any interference with the surrounding objects.  
 ME: Mechanical end SE: Stroke end  
 \*3 Reference position for calculating the moment Ma.

■ Dimensions/Weight by Stroke \* Brake-equipped models are heavier by 0.3kg.

Stroke	50	100	150	200	250	300	350	400	450	500	550	600
L	241.4	291.4	341.4	391.4	441.4	491.4	541.4	591.4	641.4	691.4	741.4	791.4
N	81	131	181	231	281	331	381	431	481	531	581	631
P	66	116	166	216	266	316	366	416	466	516	566	616
R	81	31	81	31	81	31	81	31	81	31	81	31
U	1	2	2	3	3	4	4	5	5	6	6	7
m	6	8	8	10	10	12	12	14	14	16	16	18
Weight (kg)	1.7	1.9	2.1	2.3	2.5	2.7	2.9	3.1	3.3	3.5	3.7	3.9

③ Compatible Controllers

The RCA series actuators can operate with the controllers below. Select the controller according to your usage.

Name	External View	Model	Description	Max. Positioning Points	Input Voltage	Power Supply Capacity	Standard Price	See Page
Solenoid Valve Type		AMEC-C-30I②-NP-2-1	Easy-to-use controller, even for beginners	3 points	AC100V	2.4A rated	-	→ P477
		ASEP-C-30I②-NP-2-0	Operable with same signal as solenoid valve. Supports both single and double solenoid types. No homing necessary with simple absolute type.					
Splash-Proof Solenoid Valve Type		ASEP-CW-30I②-NP-2-0						
Positioner Type		ACON-C-30I②-NP-2-0	Positioning is possible for up to 512 points	512 points	DC24V	(Standard) 1.3A rated 4.4A max.	-	
Safety-Compliant Positioner Type		ACON-CG-30I②-NP-2-0						
Pulse Train Input Type (Differential Line Driver)		ACON-PL-30I②-NP-2-0	Pulse train input type with differential line driver support	(-)	DC24V	(Power-saving) 1.3A rated 2.2A max.	-	→ P535
Pulse Train Input Type (Open Collector)		ACON-PO-30I②-NP-2-0	Pulse train input type with open collector support					
Serial Communication Type		ACON-SE-30I②-N-0-0	Dedicated to serial communication	64 points				
Field Network Type		RACON-30②	Dedicated to field network	768 points				→ P503
Program Control Type		ASEL-C-1-30①②-NP-2-0	Programmed operation is possible Can operate up to 2 axes	1500 points				→ P567

\* This is for the single-axis ASEL.  
 \* ① is a placeholder for the encoder type (I: incremental, A: absolute).  
 \* ② is a placeholder for the code "HA" or "LA", when the high-acceleration/deceleration option or the energy-saving option is selected.