

RCP2-SA5R

ROBO Cylinder Slider Type 52mm Width Pulse Motor Side-Mounted Motor

■ Configuration: **RCP2** — **SA5R** — **I** — **42P** — — — — —

Series — Type — Encoder — Motor — Lead — Stroke — Compatible Controllers — Cable Length — Option

I: Incremental * The Simple absolute encoder models are labeled as "I".
 42P: Pulse motor 42□ size
 12: 12mm
 6: 6mm
 3: 3mm
 50: 50mm
 800: 800mm (50mm pitch increments)
 P1: PCON
 RPCON
 PSEL
 P3: PMEC
 PSEP
 N: None
 P: 1m
 S: 3m
 M: 5m
 X : Custom Length
 R : Robot cable

See Options below
 * Be sure to specify which side the motor is to be mounted (ML/MR).

* See page Pre-35 for explanation of each code that makes up the configuration name.



Pictured: Left-mounted motor model (ML).

Technical References A-5

- POINT** Notes on Selection
- When the stroke increases, the maximum speed will drop to prevent the ball screw from reaching the critical rotational speed. Use the actuator specification table below to check the maximum speed at the stroke you desire.
 - Since the RCP2 series use a pulse motor, the load capacity decreases at high speeds. Check in the Speed vs. Load Capacity graph to see if your desired speed and load capacity are supported.
 - The load capacity is based on operation at an acceleration of 0.3G (0.2G for the 3mm-lead model, or when used vertically). These values are the upper limits for the acceleration.

Speed vs. Load Capacity

Due to the characteristics of the pulse motor, the RCP2 series' load capacity decreases at high speeds. In the table below, check if your desired speed and load capacity are supported.

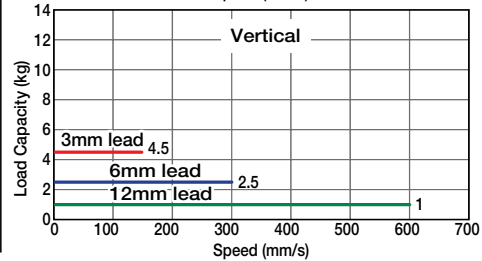
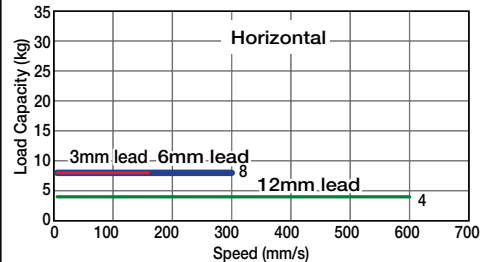

Actuator Specifications

Lead and Load Capacity

(Note 1) Please note that the maximum load capacity decreases as the speed increases.

Stroke and Maximum Speed

Model	Lead (mm)	Max. Load Capacity (Note 1)		Stroke (mm)
		Horizontal (kg)	Vertical (kg)	
RCP2-SA5R-I-42P-12-①-②-③-④	12	4	1	50 ~ 800 (50mm increments)
RCP2-SA5R-I-42P-6-①-②-③-④	6	8	2.5	
RCP2-SA5R-I-42P-3-①-②-③-④	3	8	4.5	

Stroke Lead	50 ~ 550 (50mm increments)	600 (mm)	650 (mm)	700 (mm)	750 (mm)	800 (mm)
12	600	540	460	400	360	300
6	300	270	230	200	180	150
3	150	135	115	100	90	75

Legend ① Stroke ② Compatible controller ③ Cable length ④ Options

(Unit: mm/s)

① Stroke List

Stroke (mm)	Standard Price
50	-
100	-
150	-
200	-
250	-
300	-
350	-
400	-
450	-
500	-
550	-
600	-
650	-
700	-
750	-
800	-

④ Option List

Name	Option Code	See Page	Standard Price
Brake	B	→ A-25	-
Reversed-home	NM	→ A-33	-
Left-Mounted Motor (Standard)	ML	→ A-33	-
Right-Mounted Motor	MR	→ A-33	-
Slider Roller	SR	→ A-36	-

③ Cable List

Type	Cable Symbol	Standard Price
Standard	P (1m)	-
	S (3m)	-
	M (5m)	-
Special Lengths	X06 (6m) ~ X10 (10m)	-
	X11 (11m) ~ X15 (15m)	-
	X16 (16m) ~ X20 (20m)	-
Robot Cable	R01 (1m) ~ R03 (3m)	-
	R04 (4m) ~ R05 (5m)	-
	R06 (6m) ~ R10 (10m)	-
	R11 (11m) ~ R15 (15m)	-
	R16 (16m) ~ R20 (20m)	-

* See page A-39 for cables for maintenance.

Actuator Specifications

Item	Description
Drive System	Ball screw Ø10mm C10 grade
Positioning Repeatability	±0.02mm
Lost Motion	0.1mm or less
Base	Material: Aluminum (white alumite treated)
Allowable Static Moment	Ma: 18.6 N·m Mb: 26.6 N·m Mc: 47.5 N·m
Allowable Dynamic Moment (*)	Ma: 4.9 N·m Mb: 6.8 N·m Mc: 11.7 N·m
Overhang Load Length	Ma direction: 150mm or less; Mb-Mc direction: 150mm or less
Ambient Operating Temp./Humidity	0~40°C, 85% RH or less (Non-condensing)

(*) Based on 5,000km travel life.

Directions of Allowable Load Moments

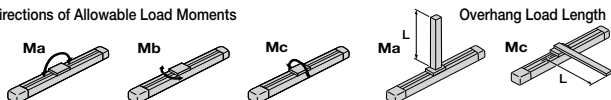

Dimensions

CAD drawings can be downloaded from IAI website. www.intelligentactuator.com

For Special Orders

A-9



*For the reversed-home model, the dimensions (distance to home) on the motor-side and that on the opposite side are flipped.

- *1. The motor-encoder cable is connected here. See page A-39 for details on cables.
- *2. When homing, the slider moves to the ME; therefore, please watch for any interference with the surrounding objects.
ME: Mechanical end
SE: Stroke end
The values enclosed in "()" are reference dimensions.

* The offset reference position for the moment Ma is the same as the SA5 type. (See P28)

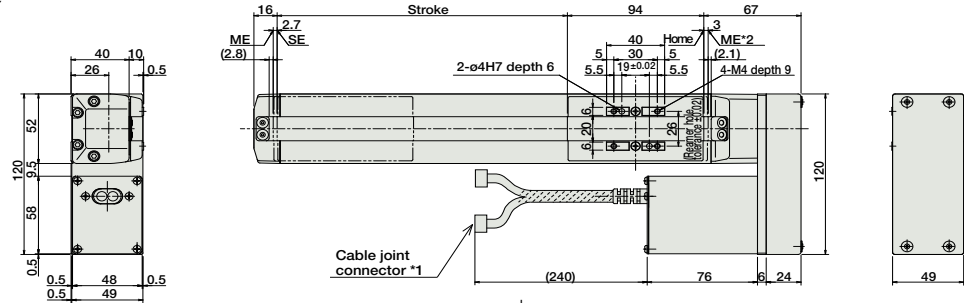

Dimensions of the brake section

* Adding a brake will increase the actuator's overall length by 40mm, and its weight by 0.4kg.

Mounting direction: symmetrically opposite

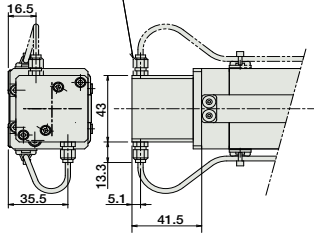

* For brake cable exiting from the side, it can only exit from the motor side.

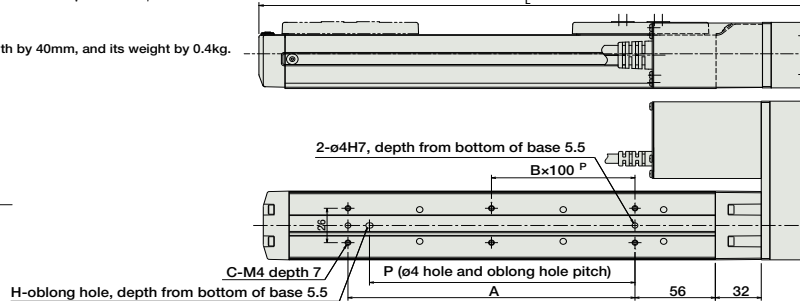

Details for Oblong Hole

Dimensions/Weight by Stroke

Stroke	50	100	150	200	250	300	350	400	450	500	550	600	650	700	750	800
L	227	277	327	377	427	477	527	577	627	677	727	777	827	877	927	977
A	73	100	100	200	200	300	300	400	400	500	500	600	600	700	700	800
B	0	0	0	1	1	2	2	3	3	4	4	5	5	6	6	7
C	4	4	4	6	6	8	8	10	10	12	12	14	14	16	16	18
H	0	1	1	1	1	1	1	1	1	1	1	1	1	1	1	1
P	0	85	85	185	185	285	285	385	385	485	485	585	585	685	685	785
Weight (kg)	2.0	2.1	2.2	2.3	2.4	2.6	2.7	2.8	2.9	3.0	3.1	3.3	3.4	3.5	3.6	3.7

Compatible Controllers

The RCP2 series actuators can operate with the controllers below. Select the controller according to your usage.

Name	External View	Model	Description	Max. Positioning Points	Input Voltage	Power Supply Capacity	Standard Price	See Page
Solenoid Valve Type		PMEC-C-42PI-NP-2-①	Easy-to-use controller, even for beginners	3 points	AC100V AC200V	See P481	-	→ P477
		PSEP-C-42PI-NP-2-0	Operable with same signal as solenoid valve. Supports both single and double solenoid types. No homing necessary with simple absolute type.					
Splash-Proof Solenoid Valve Type		PSEP-CW-42PI-NP-2-0						
Positioner Type		PCON-C-42PI-NP-2-0	Positioning is possible for up to 512 points	512 points	DC24V	2A max.	-	→ P525
Safety-Compliant Positioner Type		PCON-CG-42PI-NP-2-0						
Pulse Train Input Type (Differential Line Driver)		PCON-PL-42PI-NP-2-0	Pulse train input type with differential line driver support	(-)	DC24V	2A max.	-	→ P525
Pulse Train Input Type (Open Collector)		PCON-PO-42PI-NP-2-0	Pulse train input type with open collector support					
Serial Communication Type		PCON-SE-42PI-N-0-0	Dedicated to serial communication	64 points				
Field Network Type		RPCON-42P	Dedicated to field network	768 points				→ P503
Program Control Type		PSEL-C-1-42PI-NP-2-0	Programmed operation is possible Can operate up to 2 axes	1500 points				→ P557

* This is for the single-axis PSEL.

* ① is a placeholder for the power supply voltage (1: 100V / 2: 100~240V).