

RCP2-HS8C

ROBO Cylinder High-Speed Slider Type 80mm Width Pulse Motor Straight Type
Steel Base Coupled

■ Configuration: **RCP2** — **HS8C** — **I** — **86P** — — — **P2** — —

Series — Type — Encoder — Motor — Lead — Stroke — Compatible Controllers — Cable Length — Option

I: Incremental 86P: Pulse motor
56 high output

30: 30mm 50: 50mm
1000: 1000mm
(50mm pitch increments)

P2: PCON-CF N: None B: Brake
P: 1m P: 1m NM: Reversed-home
S: 3m M: 5m SR: Slider Roller
X : Custom Length
R : Robot cable

* See page Pre-35 for explanation of each code that makes up the configuration name.



Technical References A-5

- POINT** Notes on Selection
- (1) Due to the large lead of the ball screw in high-speed actuators, operating at low speeds may cause vibration and/or noise. Therefore, use the actuator at speeds over 100mm/s.
 - (2) When the stroke increases, the maximum speed will drop to prevent the ball screw from reaching the critical rotational speed. Use the actuator specification table below to check the maximum speed at the stroke you desire.
 - (3) Since the RCP2 series use a pulse motor, the load capacity decreases at high speeds. Check in the Speed vs. Load Capacity graph to see if your desired speed and load capacity are supported.
 - (4) The load capacity is based on operation at an acceleration of 0.3G (0.2G when used vertically). The upper limit for the acceleration is 0.5G for horizontal use and 0.2G for vertical use.

■ Speed vs. Load Capacity
Due to the characteristics of the pulse motor, the RCP2 series' load capacity decreases at high speeds. In the table below, check if your desired speed and load capacity are supported.

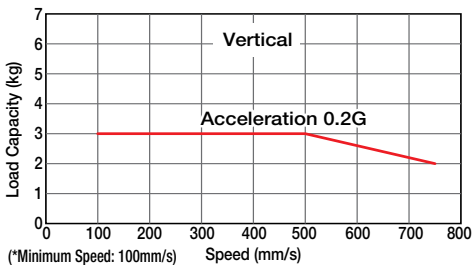
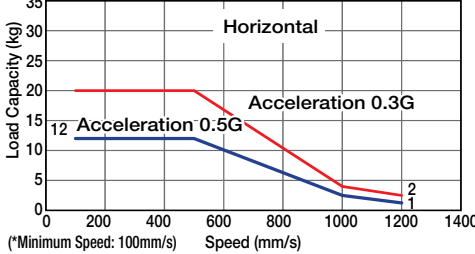

Actuator Specifications

■ Lead and Load Capacity (Note 1) Please note that the maximum load capacity decreases as the speed increases.

Model	Lead (mm)	Max. Load Capacity (Note 1)		Stroke (mm)
		Horizontal (kg)	Vertical (kg)	
RCP2-HS8C-I-86P-30-①-P2-②-③	30	~ 20	~ 3	50 ~ 1000 (50mm increments)

Legend ① Stroke ② Cable length ③ Options

■ Stroke and Maximum Speed

Stroke / Lead	50 ~ 800 (50mm increments)	~ 900 (mm)	~ 1000 (mm)
	30	1200 <750>	1000 <750>

* The values enclosed in < > apply to vertical setting. (Unit: mm/s)

① Stroke List

Stroke (mm)	Standard Price
50/100	-
150/200	-
250/300	-
350/400	-
450/500	-
550/600	-
650/700	-
750/800	-
850/900	-
950/1000	-

② Cable List

Type	Cable Symbol	Standard Price
Standard	P (1m)	-
	S (3m)	-
	M (5m)	-
Special Lengths	X06 (6m) ~ X10 (10m)	-
	X11 (11m) ~ X15 (15m)	-
	X16 (16m) ~ X20 (20m)	-
	R01 (1m) ~ R03 (3m)	-
Robot Cable	R04 (4m) ~ R05 (5m)	-
	R06 (6m) ~ R10 (10m)	-
	R11 (11m) ~ R15 (15m)	-
	R16 (16m) ~ R20 (20m)	-

* See page A-39 for cables for maintenance.

③ Option List

Name	Option Code	See Page	Standard Price
Brake	B	→ A-25	-
Reversed-home	NM	→ A-33	-
Slider Roller	SR	→ A-36	-

Actuator Specifications

Item	Description
Drive System	Ball screw ϕ 16mm C10 grade
Positioning Repeatability	\pm 0.02mm
Lost Motion	0.1mm or less
Base	Material: Special alloy steel
Allowable Static Moment	Ma: 198.9 N·m Mb: 198.9 N·m Mc: 416.7 N·m
Allowable Dynamic Moment (*)	Ma: 36.3 N·m Mb: 36.3 N·m Mc: 77.4 N·m
Overhang Load Length	Ma direction: 450mm or less; Mb-Mc direction: 450mm or less
Ambient Operating Temp./Humidity	0~40°C, 85% RH or less (Non-condensing)

(*) Based on 10,000km travel life.

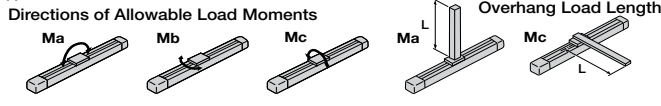

Dimensions

CAD drawings can be downloaded from IAI website. www.intelligentactuator.com

For Special Orders

A-9



* For the reversed-home model, the dimensions (distance to home) on the motor-side and that on the opposite side are flipped.

*3. Reference position for calculating the moment Ma.

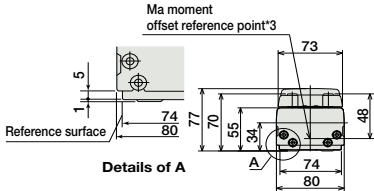

*1: The motor-encoder cable is connected here. See page A-39 for details on cables.
 *2: When homing, the slider moves to the ME; therefore, please watch for any interference with the surrounding objects.
 ME: Mechanical end
 SE: Stroke end
 The dimensions enclosed in "()" are reference dimensions.

Dimensions of the brake section

* Adding a brake will increase the actuator's overall length by 26mm, and its weight by 0.5kg.

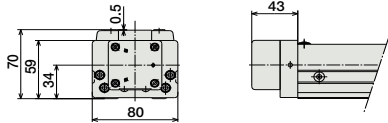

* The brake cable is passed through the actuator body and connected to the motor cable.

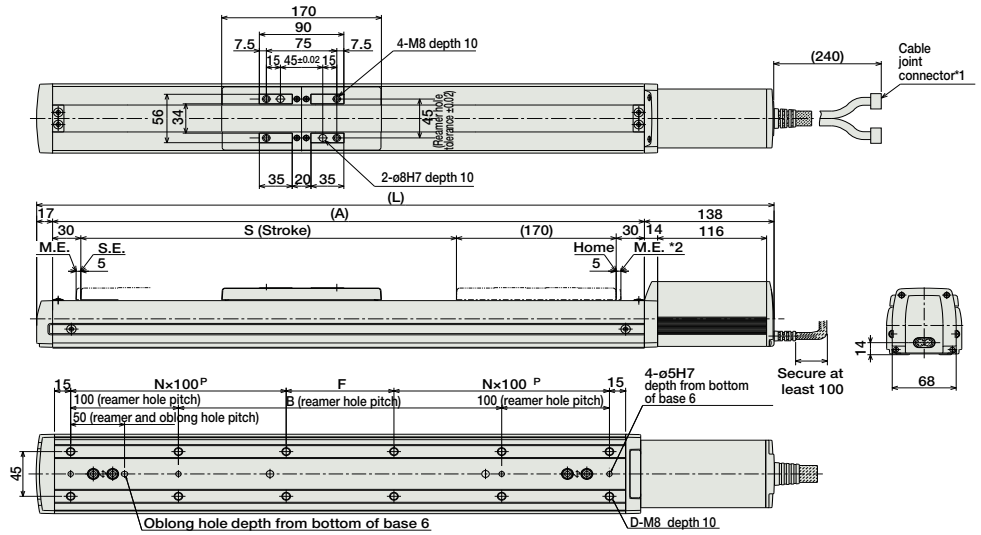

■ Dimensions/Weight by Stroke

Stroke	50	100	150	200	250	300	350	400	450	500	550	600	650	700	750	800	850	900	950	1000	
L	435	485	535	585	635	685	735	785	835	885	935	985	1035	1085	1135	1185	1235	1285	1335	1385	
A	280	330	380	430	480	530	580	630	680	730	780	830	880	930	980	1030	1080	1130	1180	1230	
B	50	100	150	200	250	300	350	400	450	500	550	600	650	700	750	800	850	900	950	1000	
D	8	8	8	10	12	12	12	14	16	16	16	18	20	20	20	22	24	24	24	24	26
F	50	100	150	0	50	100	150	0	50	100	150	0	50	100	150	0	50	100	150	0	
N	1	1	1	2	2	2	2	3	3	3	3	4	4	4	4	5	5	5	5	6	
Weight (kg)	6.6	7.1	7.6	8.1	8.6	9.2	9.7	10.2	10.7	11.3	11.7	12.3	12.8	13.4	13.9	14.5	15.0	15.5	16.1	16.6	

Compatible Controllers

The controller for the RCP2-HS8C type is a dedicated controller.

Name	External View	Model	Description	Max. Positioning Points	Input Voltage	Power Supply Capacity	Standard Price	See Page
Positioner Type		PCON-CF-86PI-NP-2-0	Positioning is possible for up to 512 points	512 points	DC24V	6A max.	-	→ P525

Note: • Please note that the encoder cable is a dedicated CF-type cable that is different from the PCON-C/CG/CY/PL/PO/SE controllers.
 • Note that a simple absolute unit cannot be used.