

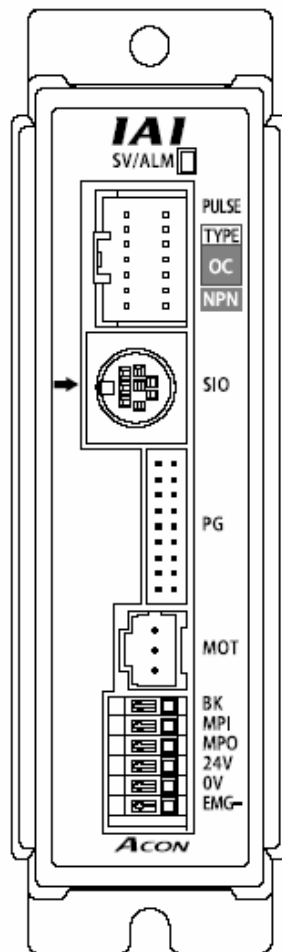

# ACON-PL/PO Controller Pulse-train Input Type

Operation Manual Third Edition



**IAI America, Inc.**



## CAUTION

### 1. UL Certification Requirement for 24-V Power Supply

Although the ACON controllers (ACON-C/CG, CY, SE and PL/PO) are UL-certified, the certification is conditional upon use of a 24-V power supply of Class 2. Therefore, if your equipment must be UL-certified, both the input power supply and I/O supply must conform to Class 2.

### 2. Use Environment

The ACON controllers can be used in an environment of pollution degree 2 or equivalent.

### 3. PC Software and Teaching Pendant Models

New functions have been added to the entire ACON controller series.

To support these new features, the communication protocol has been changed to the general Modbus (Modbus-compliant) mode. As a result, the existing PC software programs and teaching pendants compatible with RCS controllers can no longer be used.

If you are using this controller, use a compatible PC software program and/or teaching pendant selected from the following models.

	Model	Supported versions	Remarks
PC software	RCM-101-***	V 6.0.0.0 or later	All are compatible with existing RCS controllers.
Teaching pendant	RCM-T	V 2.00 or later	
Simple teaching pendant	RCM-E	V 2.00 or later	
Data setting unit	RCM-P	V 2.00 or later	

### 4. Recommendation for Backing Up Latest Data

This controller uses nonvolatile memory to store parameters. Although data in the memory is retained even after the power is cut off, the stored data will be lost if the nonvolatile memory is damaged.

It is therefore recommended that you regularly back up the latest parameters in case of accidental data loss. Regular backup will also let you restore data quickly if the controller must be replaced for other reasons.

Use one of the following methods to back up data:

[1] Use the PC software to save the data to a CD or FD.

[2] Create a position table list or parameter list to keep a written record of parameter settings.





## Safety Precautions (Please read before using the product.)



---

Before installing, operating, maintaining or inspecting this product, please peruse this operating manual as well as the operating manuals and other related documentations for all equipment and peripheral devices connected to this product in order to ensure the correct use of this product and connected equipment/devices. Those performing installation, operation, maintenance and inspection of the product must have sufficient knowledge of the relevant equipment and their safety. The precautions provided below are designed to help you use the product safely and avoid bodily injury and/or property damage.

---

In this operating manual, safety precautions are classified as “Danger,” “Warning,” “Caution” and “Note,” according to the degree of risk.

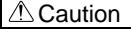
 <b>Danger</b>	Failure to observe the instruction will result in an imminent danger leading to death or serious injury.
 <b>Warning</b>	Failure to observe the instruction may result in death or serious injury.
 <b>Caution</b>	Failure to observe the instruction may result in injury or property damage.
 <b>Note</b>	The user should take heed of this information to ensure the proper use of the product, although failure to do so will not result in injury.

It should be noted that the instructions under the  **Caution** and  **Note** headings may also lead to serious consequences, if unheeded, depending on the situation.

All instructions contained herein provide vital information for ensuring safety. Please read the contents carefully and handle the product with due caution.

Please keep this operating manual in a convenient place for quick reference whenever needed, and also make sure that the manual will get to the end-user.



### **Danger**

[General]

● Do not use this product for the following applications:

1. Medical equipment used to maintain, control or otherwise affect human life or physical health
2. Mechanisms and machinery designed for the purpose of moving or transporting people
3. Important safety parts of machinery

This product has not been planned or designed for applications requiring high levels of safety. Use of this product in such applications may jeopardize the safety of human life. The warranty covers only the product as it is delivered.

## [Installation]

- Do not use this product in a place exposed to ignitable, inflammable or explosive substances. The product may ignite, burn or explode.
- Avoid using the product in a place where it may come in contact with drops of water or oil.
- Never cut and/or reconnect the cables supplied with the product for the purpose of extending or shortening the cable length. Doing so may result in fire.

## [Operation]

- Do not pour water onto the product. Spraying water over the product, washing it with water or using it in water may cause the product to malfunction, resulting in injury, electric shock, fire, etc.

## [Maintenance, Inspection, Repair]

- Never modify the product. Unauthorized modification may cause the product to malfunction, resulting in injury, electric shock, fire, etc.
- Do not disassemble and reassemble the product. Doing so may result in injury, electric shock, fire, etc.



## Warning

## [General]

- Do not use the product outside the specifications. Using the product outside the specifications may cause it to fail, stop functioning or sustain damage. It may also significantly reduce the service life of the product. In particular, observe the maximum loading capacity and speed.

## [Installation]

- If the machine will stop in the case of system problem such as emergency stop or power failure, design a safety circuit or other device that will prevent equipment damage or injury.
- Be sure to provide Class D grounding for the controller and actuator (formerly Class 3 grounding: Grounding resistance at 100  $\Omega$  or less). Leakage current may cause electric shock or malfunction.
- Before supplying power to and operating the product, always check the operation area of the equipment to ensure safety. Supplying power to the product carelessly may cause electric shock or injury due to contact with the moving parts.
- Wire the product correctly by referring to the operation manual. Securely connect the cables and connectors so that they will not be disconnected or come loose. Failure to do so may cause the product to malfunction or cause fire.

## [Operation]

- Do not touch the terminal block or various switches while the power is supplied to the product. Failure to observe this instruction may result in electric shock or malfunction.
- Before operating the moving parts of the product by hand (for the purpose of manual positioning, etc.), confirm that the servo is turned off (using the teaching pendant). Failure to observe this instruction may result in injury.
- Do not scratch the cables. Scratching, forcibly bending, pulling, winding, crushing with heavy object or pinching a cable may cause it to leak current or lose continuity, resulting in fire, electric shock, malfunction, etc.

- If the product is generating heat, smoke or a strange smell, turn off the power immediately. Continuing to use the product may result in product damage or fire.
- If any of the internal protective devices (alarms) of the product has actuated, turn off the power immediately. Continuing to use the product may result in product damage or injury due to malfunction. Once the power supply is cut off, investigate and remove the cause and then turn on the power again.
- If the LEDs on the product do not illuminate after turning on the power, turn off the power immediately. The protective device (fuse, etc.) on the live side may remain active. Request repair to the IAI sales office from which you purchased the product.

#### [Maintenance, Inspection, Repair]

- Before conducting maintenance/inspection, parts replacement or other operations on the product, completely shut down the power supply. At this time, take the following measures:
  1. Display a sign that reads, "WORK IN PROGRESS. DO NOT TURN ON POWER" at a conspicuous place, in order to prevent a person other than the operator from accidentally turning on the power.
  2. When two or more operators are to perform maintenance/inspection together, always call out every time the power is turned on/off or an axis is moved in order to ensure safety.

#### [Disposal]

- Do not throw the product into fire. The product may burst or generate toxic gases.



### Caution

#### [Installation]

- Do not use the product under direct sunlight (UV ray), in a place exposed to dust, salt or iron powder, in a humid place, or in an atmosphere of organic solvent, phosphate-ester machine oil, etc. The product may lose its function over a short period of time, or exhibit a sudden drop in performance or its service life may be significantly reduced. Use of the product under any of these conditions may also result in malfunction.
- Do not use the product in an atmosphere of corrosive gases (sulfuric acid or hydrochloric acid), etc. Rust may form and reduce the structural strength.
- When using the product in any of the places specified below, provide a sufficient shield. Failure to do so may result in malfunction:
  1. Place where large current or high magnetic field is present
  2. Place where welding or other operations are performed that cause arc discharge
  3. Place subject to electrostatic noise
  4. Place with potential exposure to radiation
- Do not install the product in a place subject to large vibration or impact. Doing so may result in the malfunctioning of the product.
- Provide an emergency-stop device in a readily accessible position so the device can be actuated immediately upon occurrence of a dangerous situation during operation. Lack of such device in an appropriate position may result in injury.
- Provide sufficient maintenance space when installing the product. Routine inspection and maintenance cannot be performed without sufficient space, which will eventually cause the equipment to stop or the product to sustain damage.
- Always use IAI's genuine cables for connection between the controller and the actuator. Also use IAI's genuine products for the key component units such as the actuator, controller and teaching pendant.
- Before installing or adjusting the product or performing other operations on the product, display a sign that reads, "WORK IN PROGRESS. DO NOT TURN ON POWER." If the power is turned on inadvertently, injury may result due to electric shock or sudden activation of an actuator.

## [Operation]

- Turn on the power to individual equipment one by one, starting from the equipment at the highest level in the system hierarchy. Failure to do so may cause the product to start suddenly, resulting in injury or product damage.
- Do not insert a finger or object in the openings in the product. It may cause fire, electric shock or injury.

## [Maintenance, Inspection, Repair]

- Do not touch the terminals when performing an insulation resistance test. Electric shock may result. (Do not perform any withstand voltage test, since the product uses DC voltage.)



## Note

## [Installation]

- Do not place objects around the controller that will block airflows. Insufficient ventilation may damage the controller.
- Do not configure a control circuit that will cause the load to drop in case of power failure. Configure a control circuit that will prevent the table or load from dropping when the power to the machine is cut off or an emergency stop is actuated.

## [Installation, Operation, Maintenance]

- When handling the product, wear protective gloves, protective goggles, safety shoes or other necessary gear to ensure safety.

## [Disposal]

- When the product becomes no longer usable or necessary, dispose of it properly as an industrial waste.

## Others

- IAI shall not be liable whatsoever for any loss or damage arising from a failure to observe the items specified in "Safety Precautions."

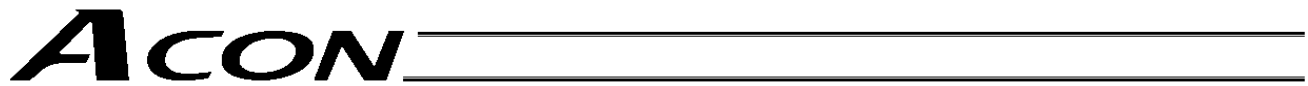

## Table of Contents

1. Overview .....	1
1.1 Introduction .....	1
1.2 How to Read Model Name .....	2
1.3 System Configuration .....	3
1.4 Steps from Unpacking to Adjustment by Trial Operation .....	4
1.5 Warranty Period and Scope of Warranty .....	6
2. Specifications .....	7
2.1 Basic Specifications .....	7
2.2 Name and Function of Each Part of the Controller .....	8
2.3 External Dimensions .....	9
3. Installation and Wiring .....	10
3.1 Installation Environment .....	10
3.2 Supplied Voltage .....	10
3.3 Noise Elimination Measures and Grounding .....	10
3.4 Heat Radiation and Installation .....	12
3.5 External Connection Diagram .....	13
3.6 Wiring the Power Supply .....	14
3.7 Wiring the Brake Forced-release Switch .....	14
3.8 Wiring the Emergency Stop Circuit .....	15
3.8.1 Cutting Off the Drive Signal (Standard) .....	15
3.8.2 Cutting Off the Motor Drive Power .....	17
3.9 Connecting the Actuator .....	18
3.9.1 Motor Relay Cable .....	18
3.9.2 Encoder Relay Cable .....	19
3.10 Connecting the I/O Shield Cable .....	20
3.11 Connecting the Communication Cable .....	21
4. Operation Using I/O Signals .....	22
4.1 Interface Circuit .....	22
4.1.1 External Input Specifications .....	22
4.1.2 External Output Specifications .....	23
4.1.3 Command Pulse Train Input Specifications .....	24
4.1.4 Recognition of Input Signals .....	25
4.2 Standard Type .....	26
4.2.1 Explanation of I/O Signals .....	26
4.2.2 Setting Parameters Required for Operation .....	31
4.2.3 Timings after Power On .....	35
4.3 Push Type .....	37
4.3.1 Explanation of I/O Signals .....	37
4.3.2 Setting Parameters Required for Operation .....	42
4.3.3 Timings after Power On .....	46
5. Parameter Settings .....	48
5.1 Parameter List .....	48
5.2 Detail Explanation of Parameters .....	50

5.2.1	Parameters Relating to Actuator Stroke Range .....	50
5.2.2	Parameters Relating to Actuator Operating Characteristics.....	52
5.2.3	Parameters Relating to External Interface .....	56
5.2.4	Servo Gain Adjustment.....	59
6.	Troubleshooting .....	62
6.1	What to Do When A Problem Occurs .....	62
6.2	Alarm Level Classification.....	63
6.3	Alarms, Causes and Actions.....	64
6.4	Messages Displayed during Teaching Pendant Operation .....	68
6.5	Common Problems and Recommended Actions.....	70
* Appendix.....		73
	Specification List of Supported Actuators .....	73
	Parameter Record.....	74

## 1. Overview

### 1.1 Introduction

This product is a pulse-train input controller used exclusively with RCA actuators. It can control actuators using the positioning control function of the host controller (PLC). The key features and functions of this controller are summarized below.

- **Dedicated Homing Signal**  
This signal supports IAI's original homing operation based on push motion at the stroke end. With this signal, homing can be performed automatically without having to program a complex sequence or using an external sensor, etc.
- **Brake Control Function**  
The electromagnetic brake power is supplied internally from the controller. However, 24 V must be supplied externally to forcibly release the brake when the servo is off.
- **Torque Limiting Function**  
This controller lets you limit torque using an external signal (set by a parameter). A signal is output when the specified torque is reached. This function enables push-motion operation, press-fit operation, etc.
- **Feed-forward Control Function**  
The response can be improved in certain situations such as when the load inertia ratio is high. Increasing the value set in the applicable parameter decreases the deviation (difference between the position command and the position feedback), thereby improving the response.
- **Primary Filter Function for Position Command**  
Soft start and stop can also be implemented in the command-pulse input mode where acceleration and deceleration settings are not considered.

When actually starting your system or if you have encountered any problem, also refer to the manuals for the actuator, teaching pendant, PC software and/or any other component you are using, in addition to this manual.

This manual does not cover all possible deviations from normal operations or unexpected phenomena such as complex signal changes resulting from critical timings. Therefore, the reader should assume that items not described in this manual are "not permitted," as a rule.

- \* This manual has been prepared with the utmost attention to ensure accuracy and completeness. However, there may still be inaccuracies and omissions. Should you find any inaccurate description or if you have any comment, please contact IAI.  
Keep this manual in a convenient place so that you can easily reference it whenever necessary.

## 1.2 How to Read Model Name

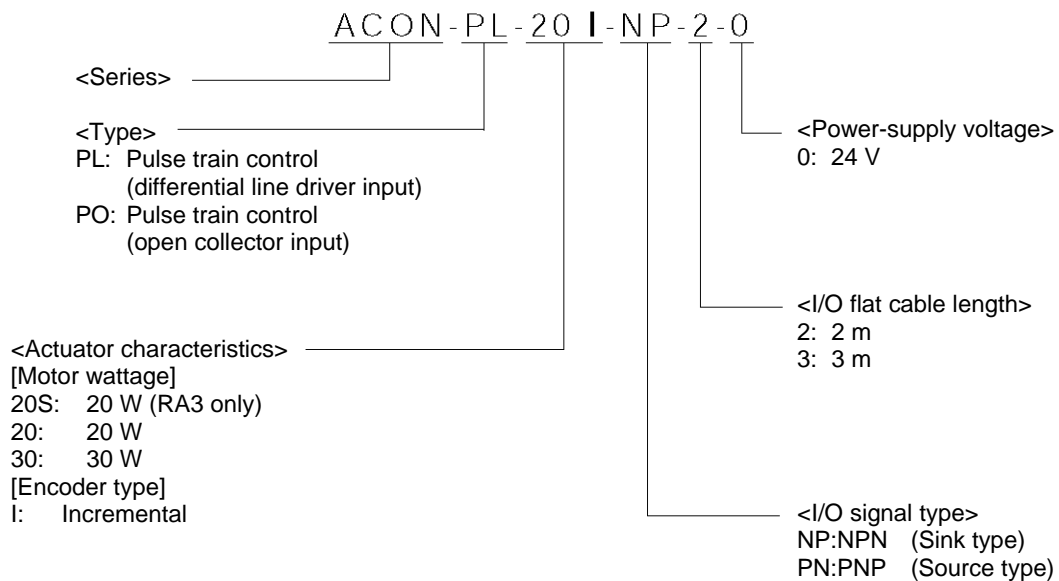

## 1.3 System Configuration

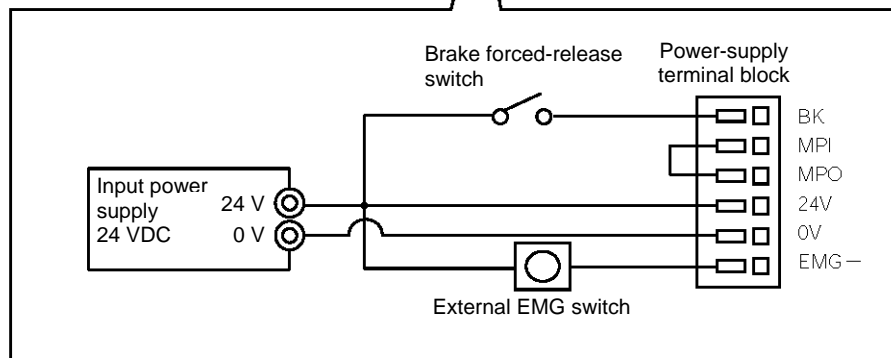
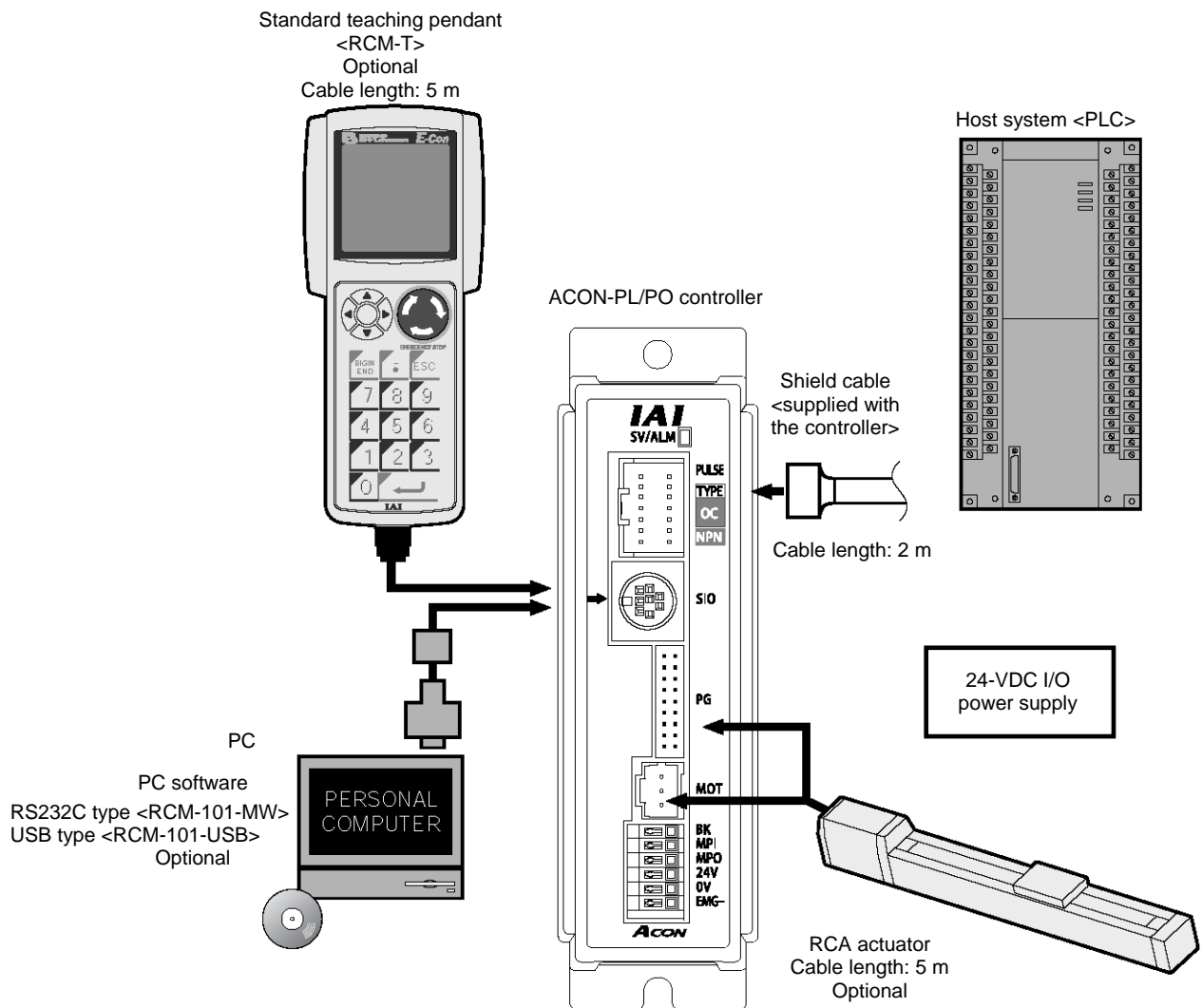

**Caution:** The BK terminal need not be connected if the actuator has no brake.

## 1.4 Steps from Unpacking to Adjustment by Trial Operation

If you are using this controller for the first time, refer to the steps explained below and perform the specified tasks carefully by making sure you check all necessary items and connect all required cables.

### 1. Checking the items in the package

Should you find any of the following items missing or of a wrong model type, please contact your IAI sales agent.

- Controller  
ACON-PL/PO
- Actuator
- I/O shield cable  
CB-PACPU-PIO\*\*\*
- Motor cable  
CB-ACS-MA \*\*\*
- Encoder cable  
CB-ACS-PA \*\*\*
- Operation manual
- Teaching pendant <Options>  
RCM-T (standard)  
RCM-E (simple)  
RCM-P (data setting)  
CON-T (standard)
- PC software <Options>  
RS-232C type <RCM-101-MW>  
USB type <RCM-101-USB>  
(Cable is supplied)
- Touch panel display  
RCM-PM-01

### 2. Installation

- [1] Affix the actuator and install the robot hand → Refer to the operation manual for your actuator.  
[2] Install the controller → Chapter 3, "Installation and Wiring"

### 3. Wiring/connection

- Wire the 24-V power supply.
- Wire the brake forced-release switch (if the actuator is equipped with a brake).
- Connect the grounding wire to ground.
- Wire the emergency stop circuit and motor drive power supply. → Chapter 3, "Installation and Wiring"
- Connect the motor cable and encoder cable.
- Connect the I/O shield cable.

### 4. Turning on the power and checking for alarms

Confirm first that the emergency stop circuit is not actuated, and then supply the 24-V power.

If the monitor LED [SV/ALM] on the front face of the controller illuminates in orange for 2 seconds and then turns off, the controller is normal. (The LED remains unlit when the servo is off.)

If the [SV/ALM] illuminates in red, it means that an alarm is present.

In this case, connect a PC or teaching pendant and check the nature of the alarm, and remove the cause by referring to Chapter 6, "Troubleshooting."

### 5. Checking the servo-on status

Confirm that the slider or rod is not contacting a mechanical end.

If the slider/rod is contacting a mechanical end, move the slider/rod in the opposite direction to provide a space in between.

If a brake is equipped, turn on the brake release switch to forcibly release the brake before moving the slider/rod.

At this time, be careful not to pinch your hand or damage the robot hand by the slider/rod, as the slider/rod may drop unexpectedly by its dead weight.

Next, forcibly output a servo-on signal from the PLC.

The actuator enters a servo lock mode. If the monitor LED [SV/ALM] on the front face of the controller illuminates in green, the controller is functioning normally.

## 6. Setting a mode

If you want to use the “standard type” PIO pattern, change the value of Parameter No. 25 to “1.”

→ Chapter 4, “Operation Using I/Os”

\* The factory setting is to use the “standard type.”

## 7. Setting an electronic gear

Determine the unit travel distance of the actuator per one pulse in input command pulse train.

→ Chapter 4, “Setting Parameters Required for Operation”

## 8. Setting the command pulse-train input mode

Set a pulse-train input pattern for command pulse input (PP•/PP, NP•/NP).

→ Chapter 4, “Setting Parameters Required for Operation”

## 9. Confirming the safety circuit operation

Confirm that the drive-signal cutoff circuit (or motor drive-power cutoff circuit) operates normally.

→ Chapter 3, “Installation and Wiring”

## 10. Adjustment by test operation

- Carry out operation check under the actual load using the host controller to check the operating characteristics. Adjust the parameters, if necessary.

→ Chapter 5, “Parameter Settings”

- Confirm that the entire system operates properly without presenting any abnormality.

## 1.5 Warranty Period and Scope of Warranty

The controller you have purchased passed IAI's strict shipping tests. This product comes with IAI's warranty, the details of which are described below.

### 1. Warranty period

The warranty period ends upon either of the following, whichever occurs first:

- Elapse of 18 months after the shipment from IAI
- Elapse of 12 months after the delivery to the specified location

### 2. Scope of warranty

IAI will repair free of charge any defect occurring within the above period despite using the product in appropriate conditions, provided that the defect is clearly the responsibility of the manufacturer. Note, however, that the following items are not covered by the warranty:

- Natural fading of paint or other deterioration normally expected over time
- Wear of consumable parts due to use
- Noise and other perceptive phenomena that do not affect mechanical function
- Problem resulting from an inappropriate handling or use by the customer
- Problem resulting from insufficient or incorrect maintenance or inspection
- Problem due to use of any part other than IAI's genuine part
- Problem resulting from alteration, etc., not authorized by IAI or its sales agent
- Problem resulting from an act of God, accident, fire, etc.

The warranty only covers the product as delivered. IAI is not responsible for any losses arising from a defect in the delivered product. The customer must hand-carry the product to IAI's factory.

Please familiarize yourself with the warranty details specified above.

## 2. Specifications

### 2.1 Basic Specifications

Specification item	Description	
Model	ACON-PL/PO	
Number of controlled axes	1 axis per unit	
Power-supply voltage	24 VDC $\pm$ 10%	
Power-supply capacity	SA4 SA5 20 W (Rated: 1.3 V / Peak: 5.1 A) SA6 30 W (Rated: 1.3 V / Peak: 5.1 A) RA3 20 W (Rated: 1.7 V / Peak: 5.1 A) RA4 20 W (Rated: 1.3 V / Peak: 5.1 A) RA4 30 W (Rated: 1.3 V / Peak: 5.1 A)	
Encoder resolution	800 P/rev	
Function/ performance	Control mode	Position control by pulse train input
	Maximum input pulse frequency	60 kpps max. (open collector) / 200 kpps max. (differential)
	Command pulse multiplier (Electronic gear: $\frac{A}{B}$ )	$A, B = 1 \sim 4096$ $\frac{1}{50} < \frac{A}{B} < \frac{50}{1}$ (set by parameters)
	Positioning complete band	0.1 mm ~ 999.999 mm (set by parameters)
Power supply for I/O signal I/F	24 VDC $\pm$ 10% Some open collectors have outputs that come with a built-in pull-up resistor. If any such open collector is used, remove the pull-up resistors or use ports without pull-up resistor.	
LED indicator	SV (green) --- Whether or not the servo is on / ALM (red) --- Whether or not an alarm is present or emergency stop is actuated.	
Serial communication	RS485, 1 channel (for teaching pendant/dedicated PC software)	
Encoder interface	Incremental specification conforming to EIA RS-422A/423A	
Forced release of electromagnetic brake	24 V is applied to the BK terminal on the power-supply terminal block.	
Cable length	Actuator cable: 20 m or shorter	
	I/O shield cable: 2 m or shorter (open collector) or 10 m or shorter (differential)	
Dielectric strength	500 VDC 10 m $\Omega$	
Environment	Ambient operating temperature	0 to 40°C
	Ambient operating humidity	85% RH or below (non-condensing)
	Operating environment	Free from corrosive gases.
	Ambient storage temperature	-10 to 65°C
	Ambient storage humidity	90% RH or below (non-condensing)
Vibration resistance	10 to 57 Hz in all X/Y/Z directions / Single amplitude: 0.035 mm (continuous), 0.075 mm (intermittent)	
Protection class	Natural air cooling (IP20)	
Weight	128 g or below	
External dimensions	35 (W) x 120 (H) x 68 (D) mm	

## 2.2 Name and Function of Each Part of the Controller

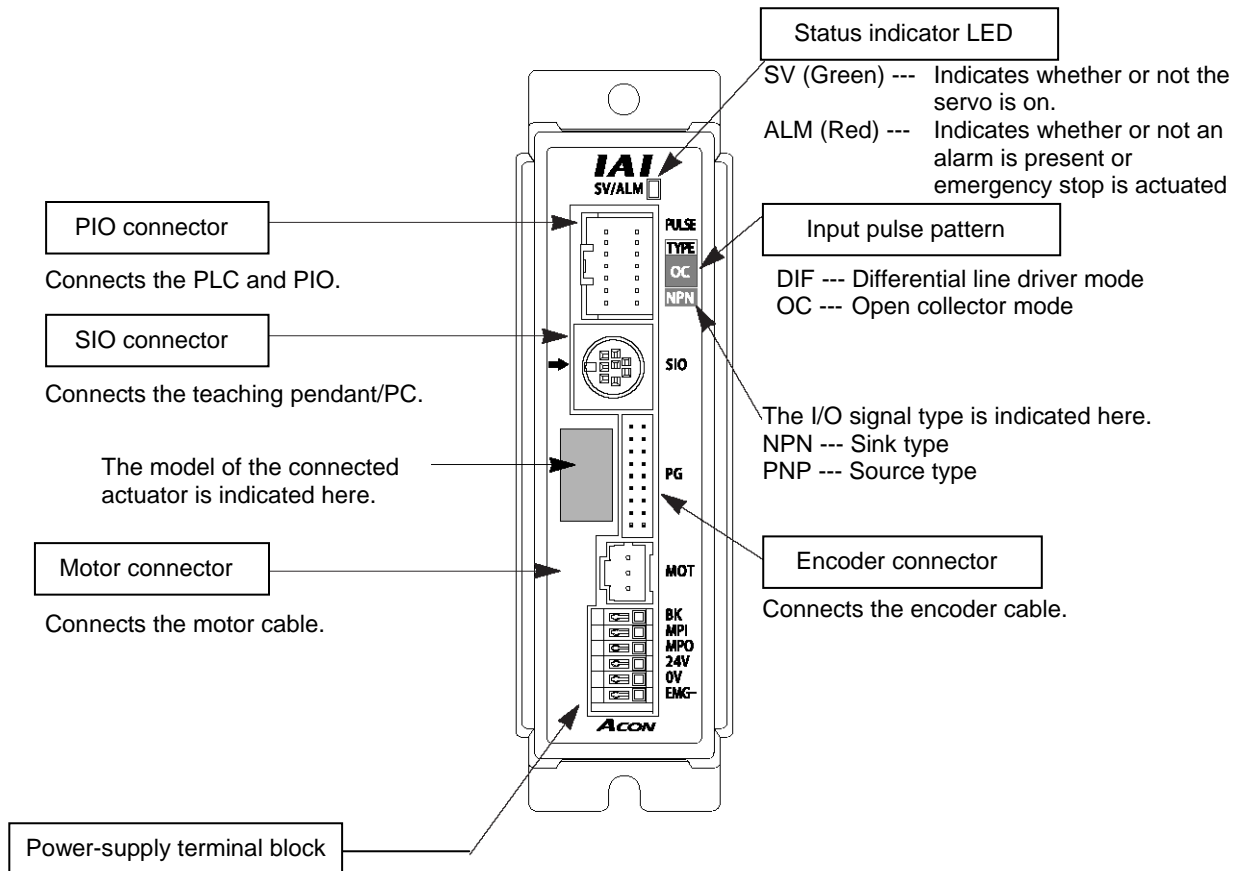

BK	Connection terminal for the brake forced-release switch to be used when the actuator is equipped with a brake. Connect the opposite side of the switch to 24 VDC.
MPI, MPO	Contacts for cutting off the motor drive power to achieve a safety level of safety category 1. MPI and MPO connect to the input side and output side of the motor power supply, respectively. (If these contacts are not used, connect them using a jumper cable. The controller is shipped with MPI and MPO connected by a jumper cable.)
24V	Positive side of the 24-VDC input power supply.
N	Negative side of the 24-VDC input power supply.
EMG	Connection terminal for the emergency stop circuit (for cutting of motor drive signals). A common ground is used, so connect the opposite side of the emergency stop switch (or contacts) to the positive side of the 24-VDC input power supply.

### ■ Model indication of the connected actuator type

The type, ball screw lead and stroke of the actuator are indicated. When connecting the cables, confirm that the actuator is of the correct specifications.

Example of indication:

RA4C	← The actuator type is RA4C.
L : 5mm	← The ball screw lead is 5 mm.
ST : 200	← The stroke is 200 mm.

## 2.3 External Dimensions

An external view and dimensions of this product are shown below.

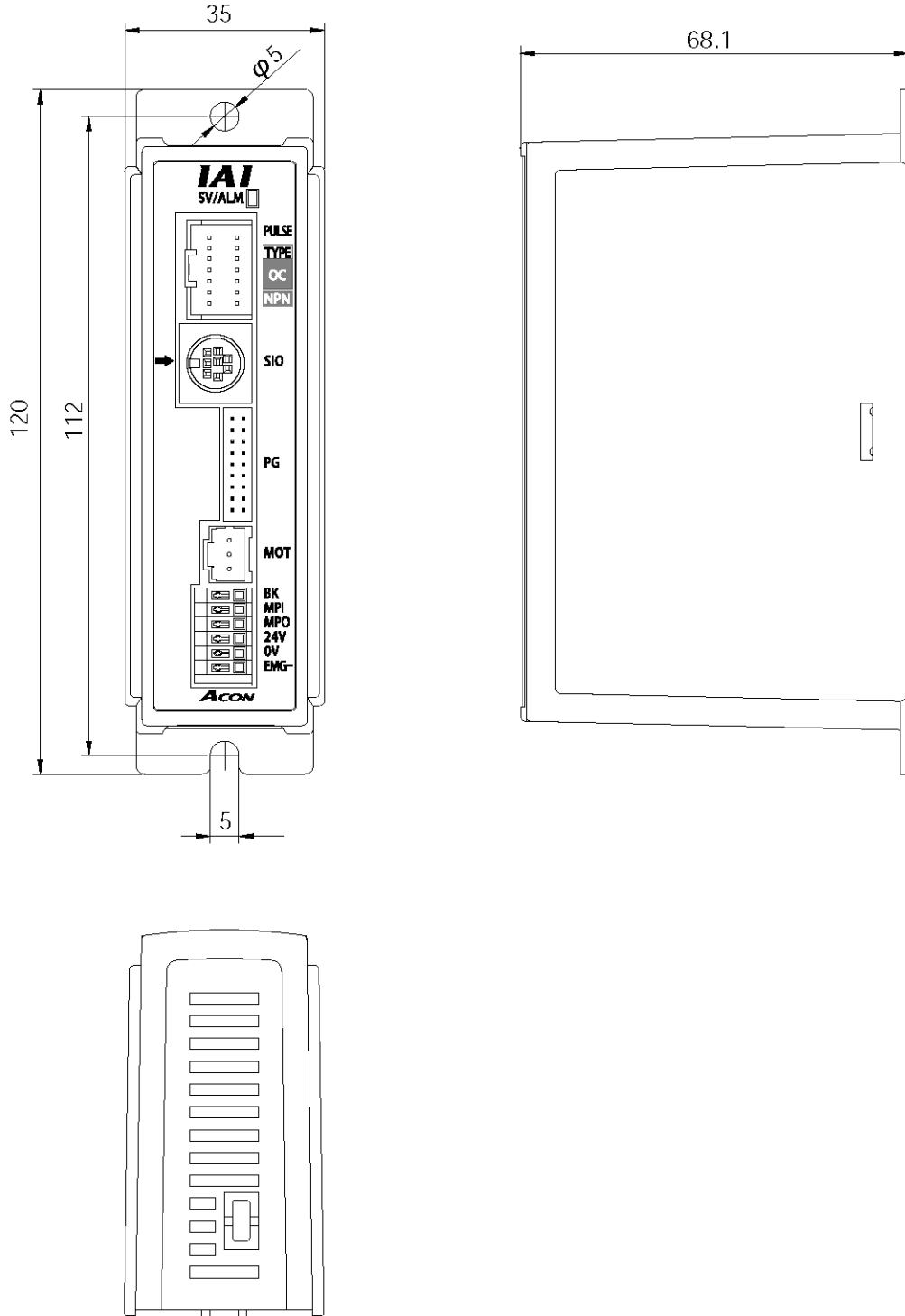

## 3. Installation and Wiring

Pay due attention to the environment where the controller is installed.

### 3.1 Installation Environment

- (1) When installing and wiring the controller, do not block the ventilation holes for cooling. (Insufficient ventilation may not only prevent the controller from demonstrating its design performance fully, but it may also cause a breakdown.)
- (2) Prevent foreign matter from entering the controller through the ventilation holes. This controller is not dustproof or splashproof (against water or oil), so avoid using the controller in a place subject to large amounts of dust, oil mist or splashes of cutting fluid.
- (3) Keep the controller from direct sunlight or irradiated heat from large heat sources such as heat treatment furnaces.
- (4) Use the controller in an environment of 0 to 40°C in ambient temperature and 85% or below in humidity (non-condensing), where the ambient air is free from corrosive or flammable gases.
- (5) Use the controller in an environment where it does not receive external vibration or impact.
- (6) Prevent electrical noise from entering the controller or connected cables.

### 3.2 Supplied Voltage

The controller takes a supplied voltage of 24 VDC  $\pm$  10%.

Actuator	SA4/SA5/RA4 (20 W) type	Rated current: 1.3 A / Peak current: 5.1 A
	SA6/RA4 (30 W) type	Rated current: 1.3 A / Peak current: 5.1 A
	RA3 type	Rated current: 1.7 A / Peak current: 5.1 A

### 3.3 Noise Elimination Measures and Grounding

The following explains the noise elimination measures that should be taken when using this controller.

- (1) Wiring and power connection
  - [1] Provide dedicated class-D grounding using a grounding wire with a size of 2.0 to 5.5 mm<sup>2</sup> or larger.

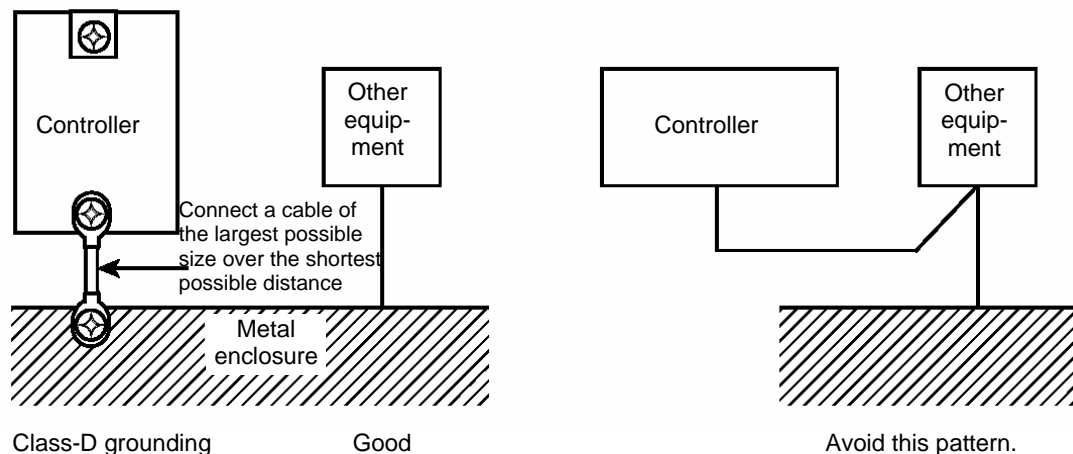

## [2] Cautions on wiring method

Use a twisted cable to connect the 24-VDC external power supply.

Separate the controller wiring from high-power lines of motive power circuits, etc. (Do not tie them together or place in the same cable duct.)

If you want to extend the motor or encoder cable beyond the length of the supplied cable, contact IAI.

## (2) Noise sources and elimination

Noise generates from many sources, but the most common sources of noise you should consider when designing a system are solenoid valves, magnet switches and relays. Noise generation from these components can be prevented by the method explained below.

AC solenoid valves, magnet switches, relays

Method --- Install a surge absorber in parallel with the coil

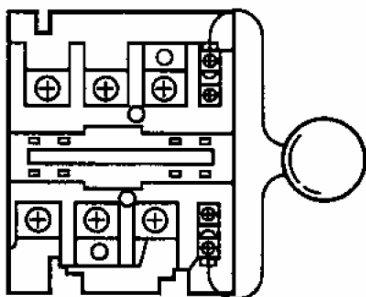

← Point

Connect to each coil over the shortest possible wiring distance.

When a surge absorber is installed on the terminal block, etc., its noise elimination effect will decrease if the distance from the coil is long.

## 3.4 Heat Radiation and Installation

Design the control panel size, controller layout and cooling method so that the temperatures around the controller will always be kept to 40°C or below.

Mount the controller vertically on the wall, as shown below. Since cooling is provided by means of natural convection, follow this orientation and provide a minimum clearance of 50 mm above and below the controller to allow sufficient airflows to circulate.

If you are installing multiple controllers side by side, provide a fan on top of the controllers to agitate the airflows as an effective way to keep the ambient temperatures constant.

Provide a minimum clearance of 80 mm between the front face of the controller and the wall (cover).

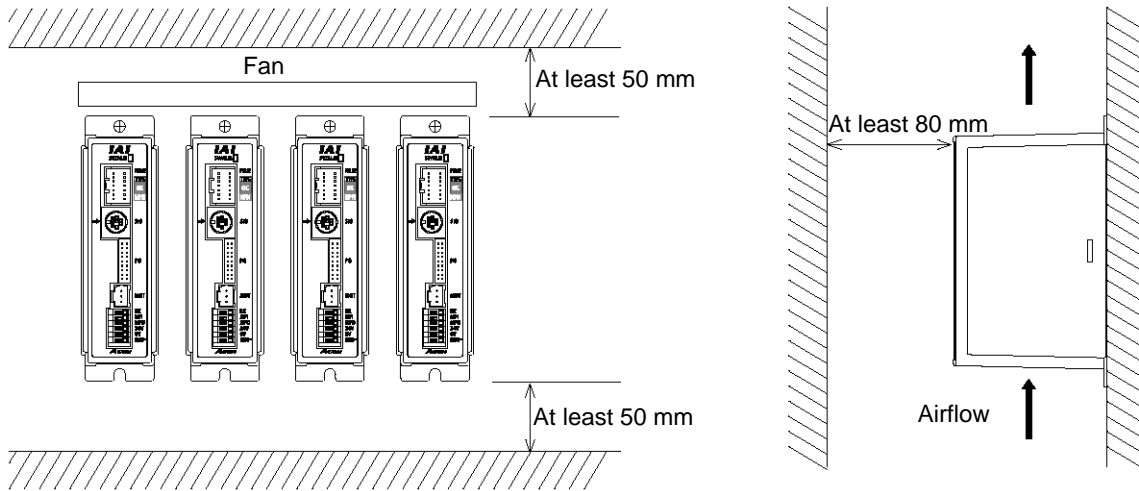

Regardless of whether you are installing one or more controllers, provide sufficient clearances around each controller to permit easy access for installation and removal of the controller.



## 3.6 Wiring the Power Supply

Connect the positive side and negative side of the 24-VDC power supply to the 24-V terminal and 0-V terminal on the power-supply terminal block, respectively.

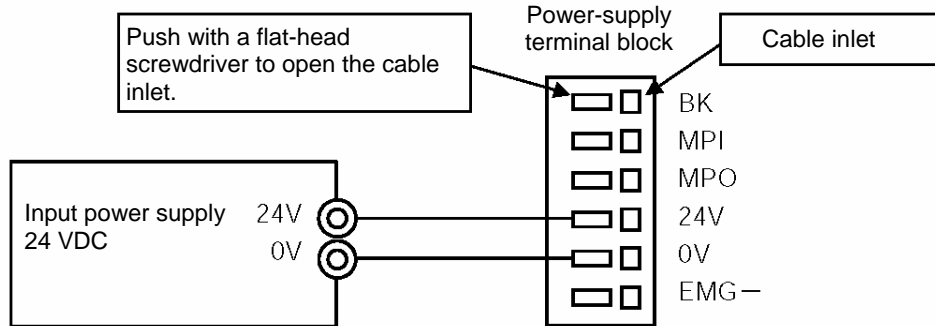

Use a wire satisfying the following specifications.

Item	Specification
Applicable wire	Twisted wire: AWG 22 (0.3 mm <sup>2</sup> ) (copper wire) (Note) Provide proper termination to prevent shorting due to contact with wire cutoff. If the wiring path is long, provide a relay terminal block and connect the original wire to another wire of a different size.
Temperature rating of insulation sheath	60°C or above
Length of bare wire	9mm

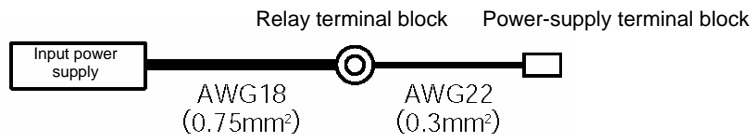

## 3.7 Wiring the Brake Forced-release Switch

If the actuator is equipped with a brake, provide a forced-release switch to permit a reset means during startup adjustment or in case of emergency.

The customer must provide the switch (24 VDC, with a minimum contact capacity of 0.2 A).

Connect one side of the switch to the positive side of the 24-VDC power supply, and connect the other side to the BK terminal on the power-supply terminal block.

The brake will be released when the switch is closed.

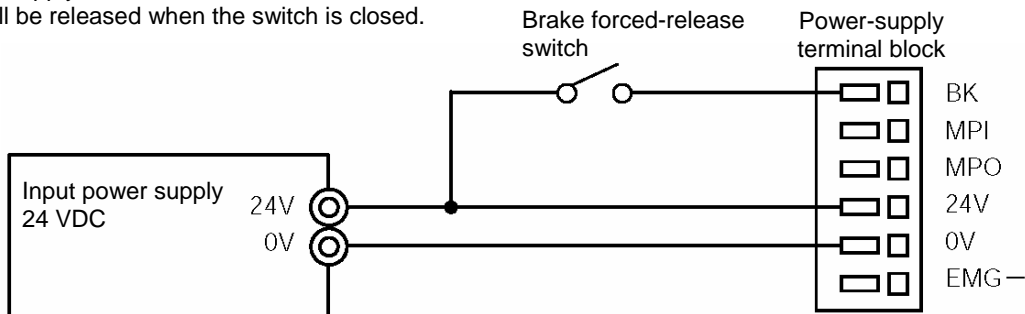

**Danger:** If the actuator is oriented vertically, exercise due caution when releasing the brake to prevent the slider/rod from dropping unexpectedly to pinch your hand or damage the robot hand or work.

## 3.8 Wiring the Emergency Stop Circuit

### 3.8.1 Cutting Off the Drive Signal (Standard)

Connect one side of the external EMG switch to the positive side of the 24-VDC power supply, and connect the other side to the BK terminal.

(Note) The EMG switch on the teaching pendant works only on the controller connected to the switch.

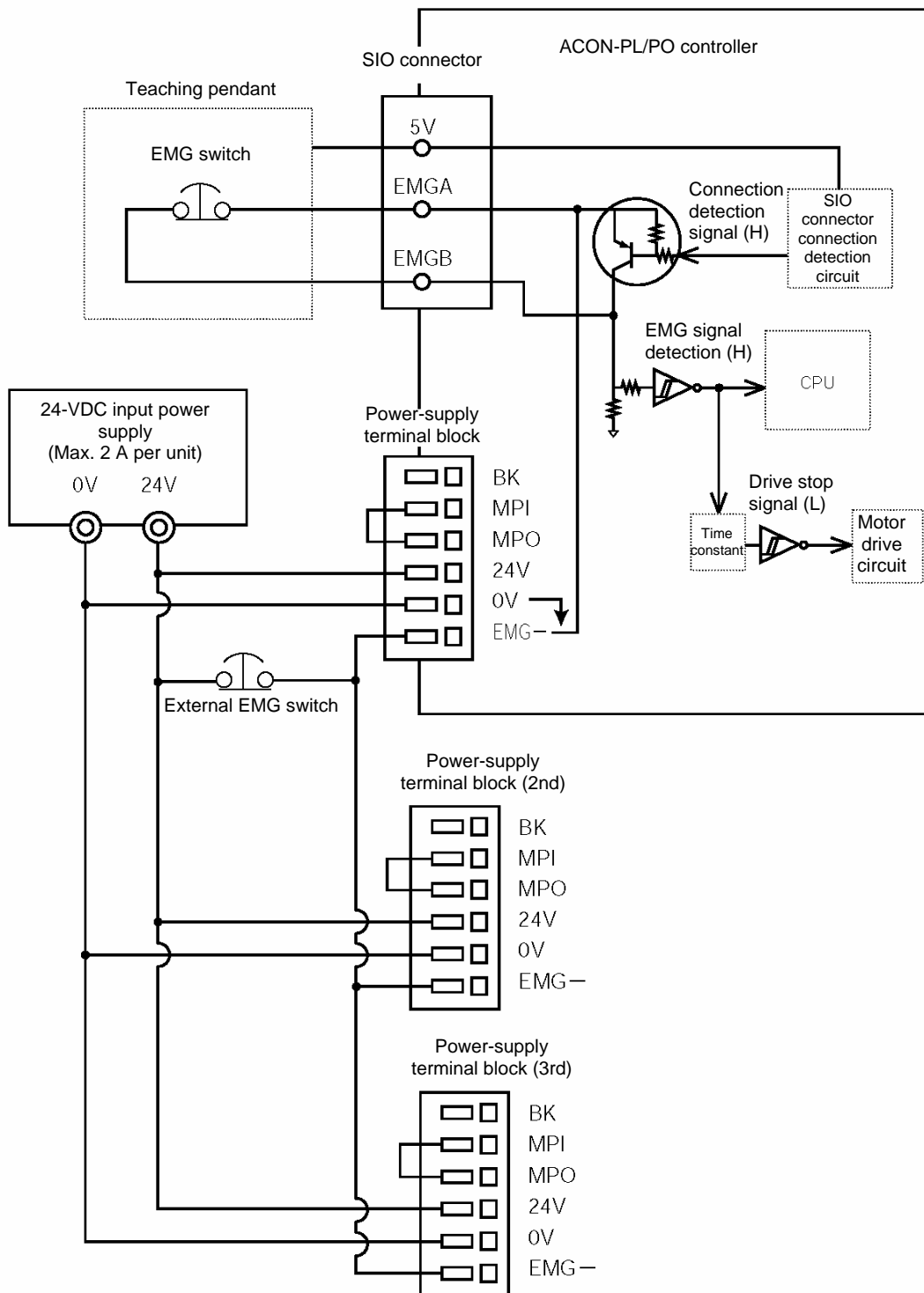

If a separate emergency stop circuit is provided to stop the entire system, or when multiple controllers are linked together and each controller has a different power supply, connect external EMG relay contacts.

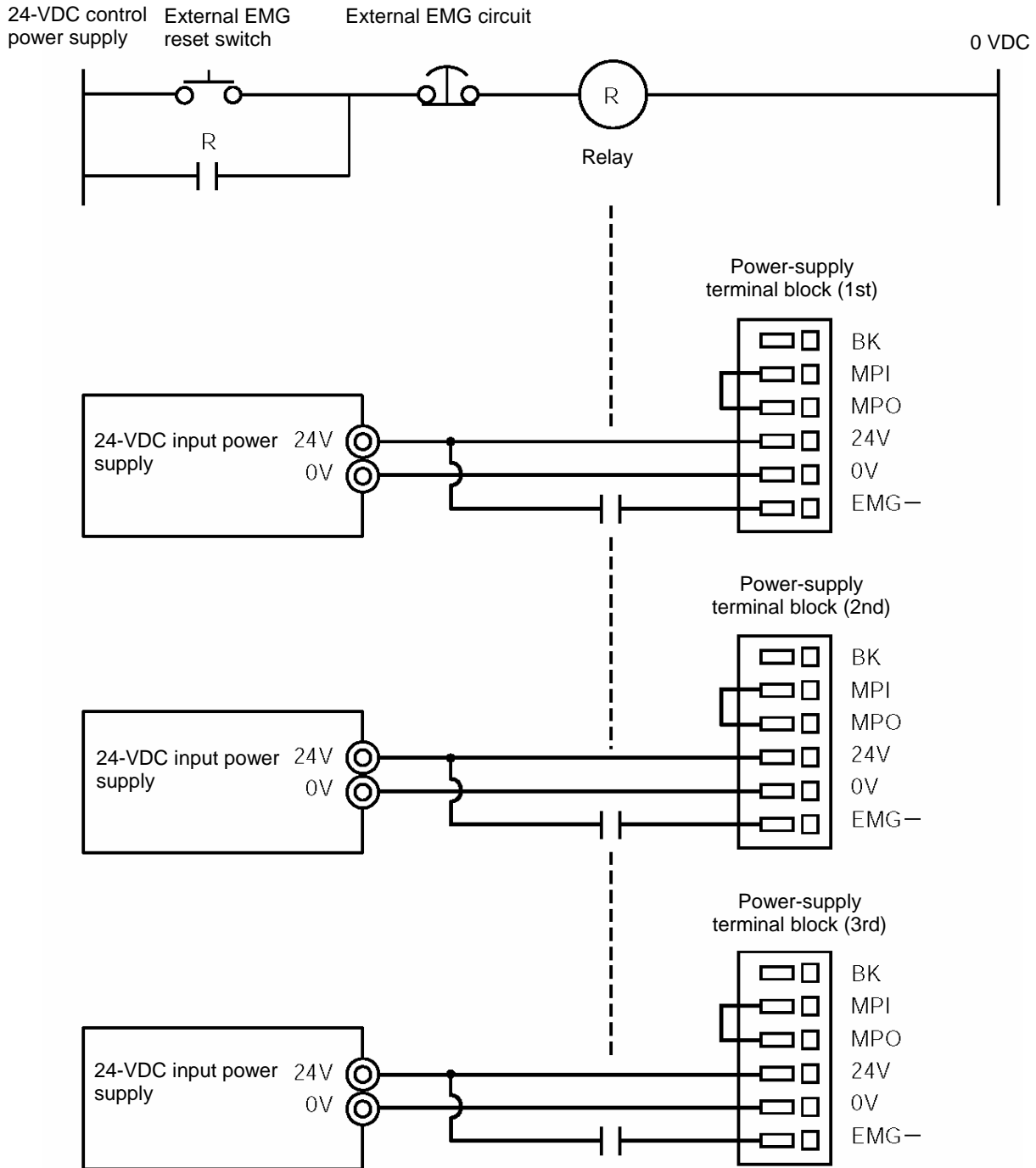

## 3.8.2 Cutting Off the Motor Drive Power

If the motor drive power must be cut off in order to meet the required safety category of the entire system, connect external EMG relay contacts between the MPI terminal and MPO terminal.

Also connect the 24-V controller power supply to the EMG terminal.

(Note) The EMG switch on the teaching pendant cuts off the motor driver signal. It does not cut off the motor drive power.

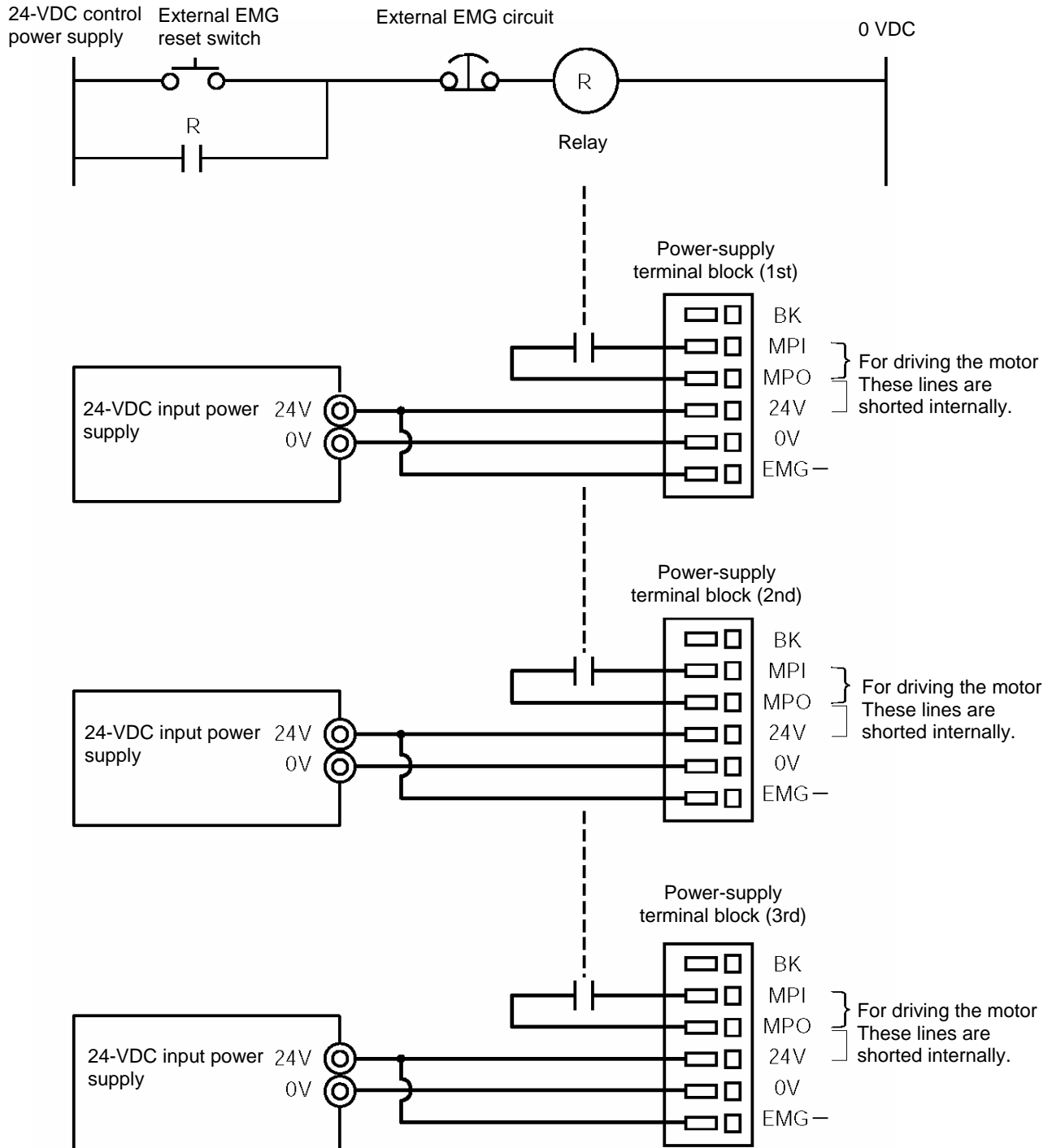

## 3.9 Connecting the Actuator

### 3.9.1 Motor Relay Cable

- Connect the motor relay cable to the MOT connector.
- Signal table of controller-end connector (CN2)

Pin No.	Wire color	Signal abbreviation	Description
1	Red	U	Motor drive phase U
2	White	V	Motor drive phase V
3	Black	W	Motor drive phase W

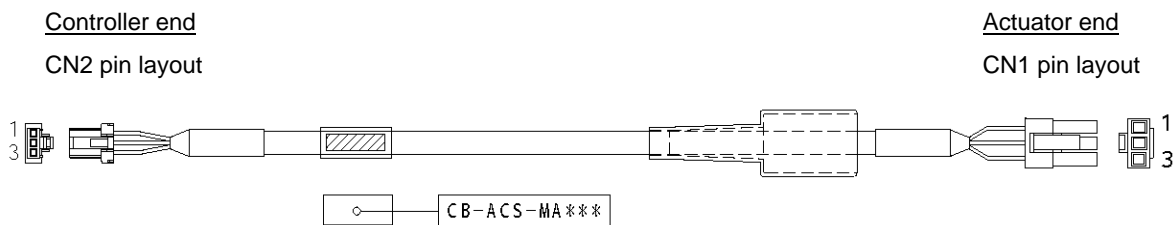

Cable color	Signal abbreviation	Pin No.
Red	U	1
White	V	2
Black	W	3

Housing: DF1E-3S-2.5C (Hirose)  
 Socket contact: DF1E-2022SC (Hirose)  
 (or DF1B-2022SC)

Cable color	Signal abbreviation	Pin No.
Red	U	1
White	V	2
Black	W	3

Housing: SLP-03V (J.S.T. Mfg.)  
 Socket contact: BSF-21T-P1.4 (J.S.T. Mfg.)

## 3.9.2 Encoder Relay Cable

- Connect the encoder relay cable to the PG connector.
- Signal table of controller-end connector (CN2)

Pin No.	Signal abbreviation	Description
1	F.G	Shielded wire
2	-	(Not used)
3	-	(Not used)
4	-	(Not used)
5	GND	Encoder power output
6	5V	
7	VPS	Encoder control signal output
8	-	(Reserved)
9	ENZ	Encoder differential signal phase-Z input
10	ENZ	
11	ENB	Encoder differential signal phase-B input
12	ENB	
13	ENA	Encoder differential signal phase-A input
14	ENA	
15	BK -	Brake power -
16	BK +	Brake power +
17	LS -	Home check sensor
18	LS +	

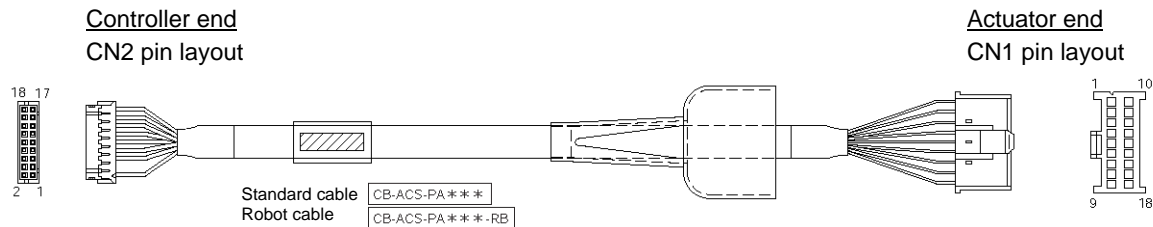

CN2				CN1				
Cable color		Signal abbreviation	Pin No.	Pin No.	Signal abbreviation		Cable color	
Robot cable	Standard cable				Standard cable	Robot cable		
White/Purple	Blue	LS+	18	1	ENA	Gray	White/Blue	
White/Gray	Orange	LS-	17	2	ENÁ	Red	White/Yellow	
Yellow	Green	BK+	16	3	ENB	Black	White/Red	
Blue	Brown	BK-	15	4	ENB	Yellow	White/Black	
White/Blue	Gray	ENA	14	5	—	-	-	
White/Yellow	Red	ENÁ	13	6	—	-	-	
White/red	Black	ENB	12	7	LS+	Blue	White/Purple	
White/Black	Yellow	ENB	11	8	—	-	-	
Orange	Pink	ENZ	10	9	FG	Drain	Drain	
Green	Purple	ENZ	9	10	ENZ	Pink	Orange	
Purple	White	—	8	11	ENZ	Purple	Green	
Gray	Blue/Red	VPS	7	12	—	White	Purple	
Red	Orange/White	5V	6	13	VPS	Blue/Red	Gray	
Black	Green/White	GND	5	14	5V	Orange/White	Red	
-	-	—	4	15	GND	Green/White	Black	
-	-	—	3	16	LS-	Orange	White/Gray	
-	-	—	2	17	BK-	Brown	Blue	
Drain	Drain	F.G	1	18	BK+	Green	Yellow	

Housing: PHDR-18VR (J.S.T. Mfg.)  
Contact: SPHD-001T-P0.5 (J.S.T. Mfg.)

Plug housing: XMP-18V (J.S.T. Mfg.)  
Socket contact: BXA-001T-P0.6 (J.S.T. Mfg.)  
Retainer: XMS-09V (J.S.T. Mfg.)

## 3.10 Connecting the I/O Shield Cable

Cable model: CB-PACPU-PIO\*\*\*

(Note: \*\*\* indicates the cable length. (Example) 2 m: 020)

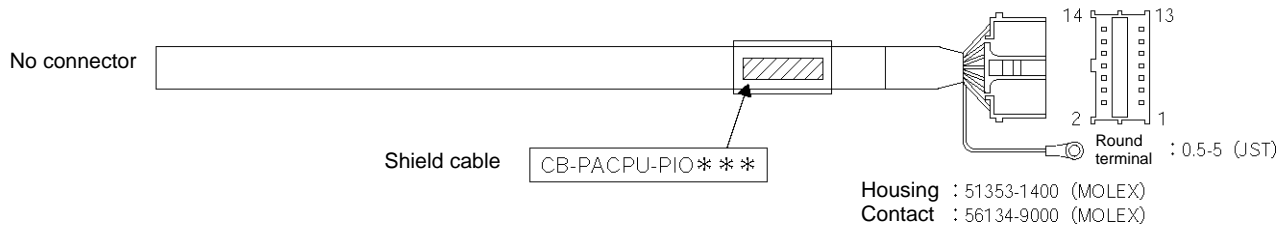

Pin No.	Color	Name	Remarks
1	Black	External 24 V	
2	White/Black	External ground	If the controller is used in the open collector mode, also use this pin for the COMMON signal for command pulses.
3	Red	SON	Servo-on signal
4	White/Red	TL	Torque-limit selection signal
5	Green	HOME	Homing signal
6	White/Green	RES/DCLR	Reset signal/deviation-counter clear signal
7	Yellow	SV	Servo-on output
8	White/Yellow	INP/TLR	Positioning complete signal/torque limit signal
9	Brown	HEND	Homing complete signal
10	White/Brown	*ALM	Alarm signal
11	Blue	Command pulse/PP	
12	White/Blue	Command pulse PP	Not connected if the controller is used in the open collector mode.
13	Gray	Command pulse/NP	
14	White/Gray	Command pulse NP	Not connected if the controller is used in the open collector mode.
-	-	FG	Shield (connected to the enclosure)

## 3.11 Connecting the Communication Cable

Connect the communication cable to the SIO connector.

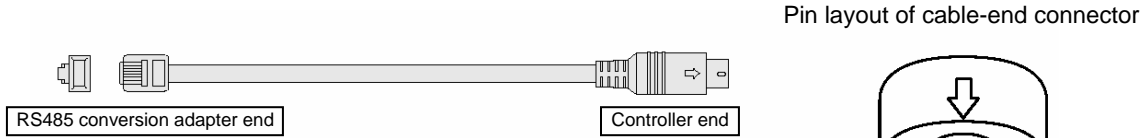

CB-RCA-SIO\*\*\*

Pin layout of cable-end connector

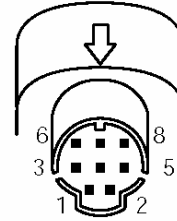

Cable color	Signal abbreviation	Pin No.	Pin No.	Signal abbreviation	Cable color
Brown	5V	1	1	SGA	Yellow
Yellow	SGA	2	2	SGB	Orange
Red	GND	3	3	5V	Brown/Green
Orange	SGB	4	4	ENB	—
Blue	GND	5	5	EMGA	Black
Green	5V	6	6	24V	—
Shorting wire UL1004AWG28 (Black)			7	GND	Red/Blue
Not connected to the shield.			8	EMGB	Black
			FG		Shield

## 4. Operation Using I/O Signals

This chapter explains the wire connections and operation timings you should know in order to perform positioning operation using a PLC with I/O signals. Two PIO patterns are available for you to choose from in accordance with your specific application.

PIO pattern	Setting (User Parameter No. 25)
Standard type (factory setting)	0
Push type	1

### 4.1 Interface Circuit

The standard interface circuit conforms to the NPN specification, but the PNP specification type is also available as an option. To simplify wiring, a common power line is used for both the NPN specification and PNP specification. Accordingly you need not reverse the power connections when using the PNP specification.

#### 4.1.1 External Input Specifications

Item	Specification
Number of input points	4 points
Input voltage	24 VDC $\pm$ 10%
Input current	5 mA per circuit
Operating voltage	ON voltage: Min. 18 V (3.5 mA) OFF voltage: Max. 6 V (1 mA)
Leak current	Max. 1 mA per point
Insulation method	Photocoupler

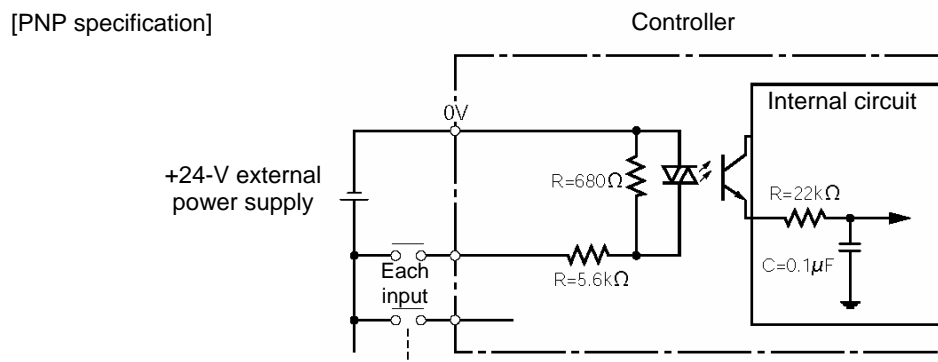
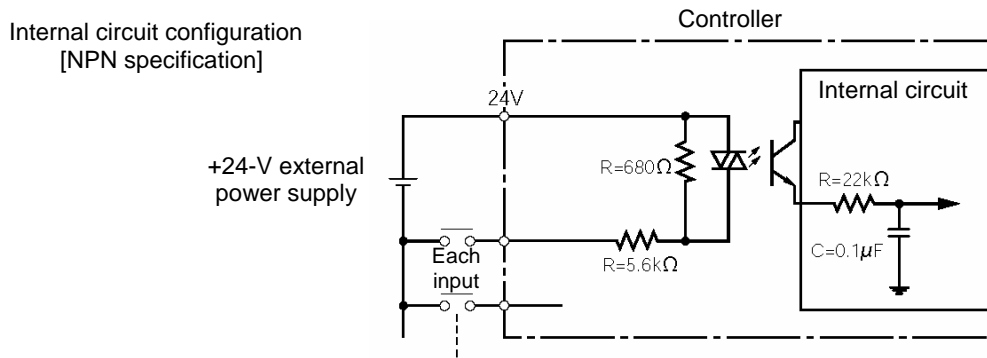

## 4.1.2 External Output Specifications

Item	Specification
Number of output points	4 points
Rated load voltage	24 VDC
Maximum current	50 mA per point
Residual voltage	Max. 2 V
Insulation method	Photocoupler

Internal circuit configuration  
[NPN specification]

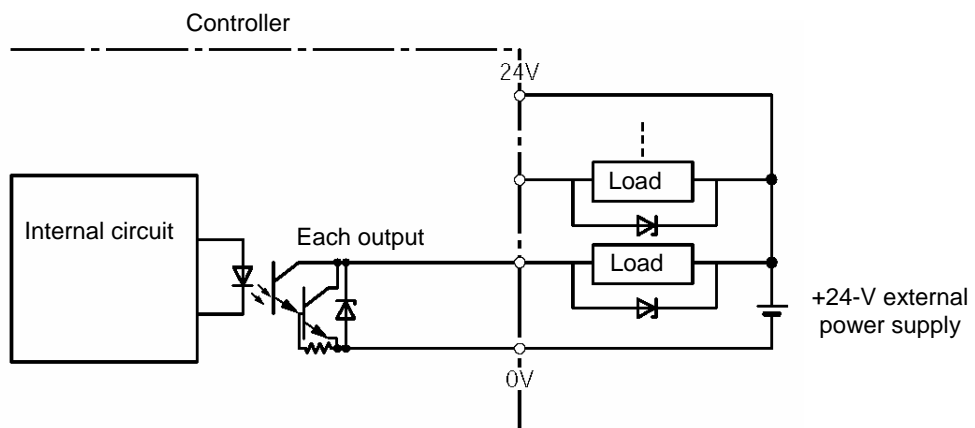

[PNP specification]

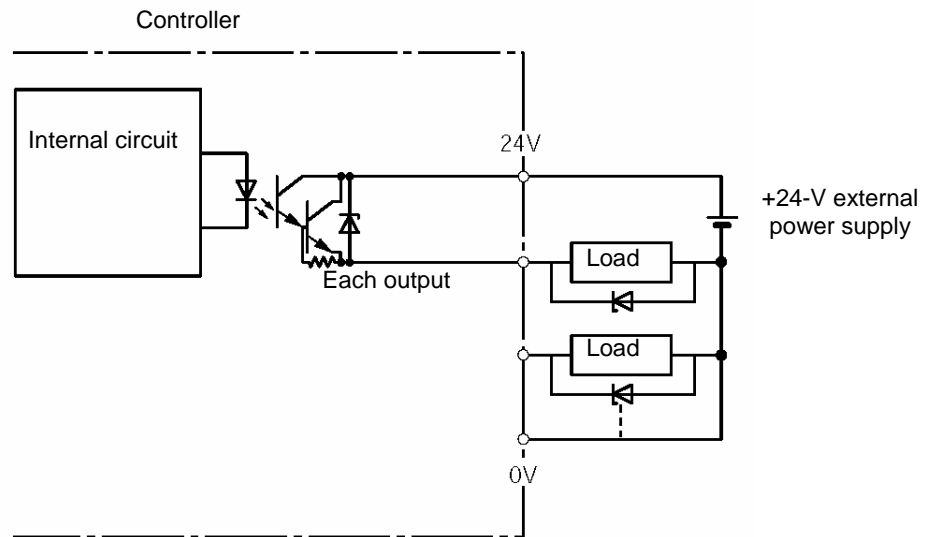

## 4.1.3 Command Pulse Train Input Specifications

[Input using a differential line driver]  
 Applicable line driver: 26C31 or equivalent

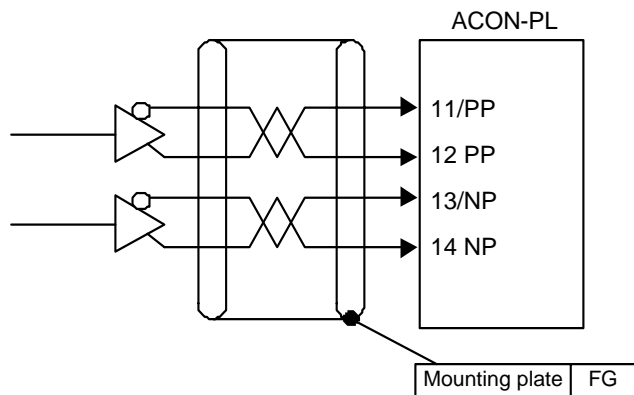

Note: Always connect the shield of the twisted pair cable joined to the connector, to the mounting plate.

[Input using an open collector]

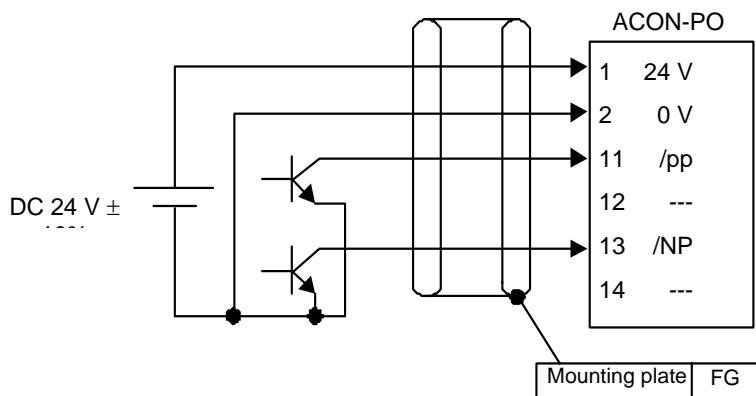

Note 1: Always connect the shield of the twisted pair cable joined to the connector, to the mounting plate.

Note 2: Some open collectors have outputs that come with a built-in pull-up resistor. If any such open collector is used, remove the pull-up resistors or use ports without pull-up resistor.  
 (Supply 24 V for pulse-train inputs.)

## 4.1.4 Recognition of Input Signals

The input signals of this controller have an input time constant to prevent malfunction due to chattering, noise, etc. Each input signal is switched when the new signal state has continued for at least 6 msec. In other words, when the input is switched from OFF to ON, the controller will recognize that the input signal is ON after 6 msec. The same applies when the input is switched from ON to OFF.

\* Excluding command pulse input (PP•/PP, NP•/NP).

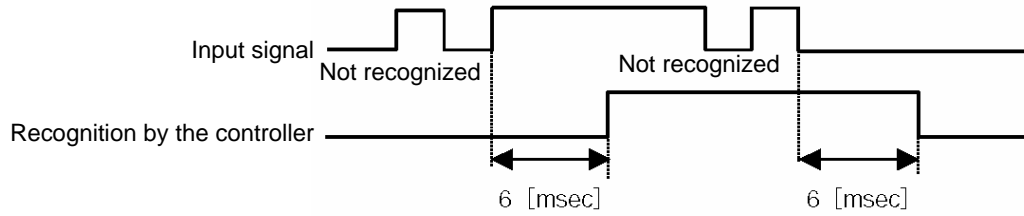

## 4.2 Standard Type

Choose the PIO pattern of this type if you wish to perform position control using pulse train input from a PLC. Set User Parameter No. 25 (PIO pattern selection) to "0." (This parameter has been set to the "standard type" prior to the shipment).

### 4.2.1 Explanation of I/O Signals

Pin No.	Signal	Name	Remarks
1	24 V	External 24 V	
2	0 V	External ground	If the controller is used in the open collector mode, also use this pin for the COMMON signal for command pulses as well as the 0V signal for the controller's control power.
3	IN0	SON	Servo-on signal
4	IN1	TL	Torque-limit selection signal
5	IN2	HOME	Homing signal
6	IN3	RES	Reset signal
7	OUT0	SV	Servo-on output
8	OUT1	INP	Positioning complete signal
9	OUT2	HEND	Homing complete signal
10	OUT3	*ALM	Alarm signal
11	/PP	Command pulse	
12	PP	Command pulse	Not connected if the controller is used in the open collector mode.
13	/NP	Command pulse	
14	NP	Command pulse	Not connected if the controller is used in the open collector mode.

#### ■ Servo-on Command Input (SON)

The servo remains on while this signal is ON.

The actuator can be operated while the SON signal is ON.

While this signal is OFF, the actuator does not operate even when the controller power is supplied.

If the SON signal is turned OFF while the actuator is operating, the actuator will decelerate at the forced-stop torque until it stops. After the actuator stops, the servo will turn off and the motor will enter a free-run state.

At this time, the function specified by the applicable parameter (electromagnetic brake) becomes.

#### ■ Reset Signal Input (RES)

This signal resets the alarms currently detected by the controller.

You can turn the RES signal ON to reset the alarms currently detected by the controller.

 **Caution:** This signal cannot reset cold-start level alarms. Identify the cause of each alarm and remove the cause before restarting the controller.

## ■ Torque-limit Selection Signal (TL)

This signal limits the motor torque.

While this signal is ON, the actuator thrust (motor torque) is limited to the torque set in User Parameter No. 57 (Torque limit).

 **Caution:** Excessive deviation (standing pulses) may generate while torque is limited (while the TL signal is ON) (for example, when the actuator receives load and is prevented from moving just like in push-motion operation).  
If the TL signal is turned OFF in this condition, the controller will instantly start controlling the actuator at the maximum torque and the actuator may move suddenly or run out of control.

This signal can be disabled using User Parameter No. 61 (Torque-limit command input). Disable the TL signal if it is not used.

## ■ Homing Signal (HOME)

This command signal is used to perform homing automatically.

The homing command is processed at the leading edge (ON edge) of the HOME signal to cause the actuator to return to its home automatically.

When the homing is completed, the HEND (homing complete) output signal turns ON.

Program the host controller (PLC) so that its current-value register will be reset to the home ("0" will be input to the register) by the current-value preset function, etc., upon turning ON of the HOME signal.

\* This signal is always enabled as long as the servo is on.

\* Even after homing has been performed once, homing can be performed again by turning the HOME signal ON.

 **Caution:**

- The HOME signal is given priority over pulse train commands. Even while the actuator is moving under a pulse train command, it will start moving to the home once the HOME signal is turned ON.
- The HOME signal is processed only at its leading edge (ON edge).
- If the SON signal turns OFF or an alarm is detected during homing, the homing operation will stop. If the servo turns off, the homing command will be cancelled even if the HOME signal is still ON. To perform homing again, turn the HOME signal OFF, and then turn it back ON.
- The actuator can be operated without using this function. If this function is not used, however, all management actions over position data will be left to the host controller.  
In this case, take necessary measures to prevent an over-stroke error, such as not sending pulse commands exceeding the effective stroke, or providing external limit switches or other devices for detecting stroke ends to forcibly stop the actuator upon detection of a stroke end.
- This controller has a command pulse counter. After homing, the controller increments/decrements command pulses and performs positioning based on command pulse data.  
However, the command pulse counter cannot be used if this function is not used. Without this function, the position where the actuator is currently stopped is used as the origin and the actuator will move from there by the number of pulses input (incremental movement). If incremental movement is repeated, positioning errors generating in individual positioning operations will accumulate and the actuator may end up not stopping at the final target position. To prevent this problem, periodically execute homing from the host controller or take other appropriate measures.

## ■ Command Pulse Input

Command pulses can be input in the open collector mode (60 kpps max.) or differential line driver mode (200 kpps max.). You can select a desired input pattern of command pulses from 90° phase-difference (phase-A/B x4) signal, pulse train + forward/reverse signal, and forward pulse/reverse pulse. The positive logic or negative logic can be selected for each of these patterns.



Caution:

- The actuator moves in the negative direction (the motor runs in the forward direction) when forward pulses are input, and moves in the positive direction (the motor runs in the reverse direction) when reverse pulses are input. (These directions are reversed if the actuator is of motor reversing type.)
  - When determining the forward/reverse directions, pay attention to the host controller setting as well as the PP•/PP and NP•/NP connection.
  - For actuator accelerations/decelerations, set values not exceeding the rated acceleration/deceleration of the actuator. (The rated acceleration/deceleration of each actuator is specified in the actuator's catalog.)
- \* The motor direction is determined based on CCW representing the forward direction when viewed from the load-end of the shaft.

- You can set one of six command pulse patterns in the command-pulse input mode.

Command-pulse input pattern		Input terminal	Forward	Reverse
Negative logic	Forward pulse train	PP • /PP		
	Reverse pulse train	NP • /NP		
	Forward pulse trains indicate motor revolutions in the positive direction, while reverse pulse trains indicate motor revolutions in the reverse direction.			
	Pulse train	PP • /PP		
	Sign	NP • /NP	Low	High
	Command pulses indicate motor revolutions, while the sign of the command indicates the rotating direction.			
	Phase-A/B pulse train	PP • /PP		
		NP • /NP		
Phase-A/B x4 pulses of 90° phase difference indicate both revolutions and rotating direction.				
Positive logic	Forward pulse train	PP • /PP		
	Reverse pulse train	NP • /NP		
	Pulse train	PP • /PP		
	Sign	NP • /NP	High	Low
	Phase-A/B pulse train	PP • /PP		
	NP • /NP			

## ■ Positioning Complete Signal (INP)

This signal turns ON when the deviation in the deviation counter (standing pulses) is within the positioning band. It remains OFF while the servo is off.



Caution:

- This signal turns ON when the servo is turned on (to perform positioning at the present position).
- This signal turns ON simply due to accumulation of deviation (standing pulses). Therefore, setting an excessively wide positioning band in the applicable position control parameter will cause this signal to turn ON once the actuator enters the positioning band during low-speed operation (before positioning is completed).
- The INP signal is recognized even when the TL signal is ON.

## ■ Homing Complete Signal (HEND)

This signal turns ON after homing has completed and the coordinate system has been established. It turns ON upon completion of homing initiated by the HOME signal or a command from the teaching pendant or PC software.

This signal turns OFF once the servo turns off. Perform homing again after the servo has turned off.



Caution:

- The software stroke limits set by the corresponding actuator parameters are effective only while this signal is ON.
- The actuator can be operated without using this function. In this case, however, take necessary measures, such as not sending pulse commands exceeding the effective stroke, or providing external limit switches for detecting stroke ends to forcibly stop the actuator upon detection of a stroke end.

## ■ Servo-on Output Signal (SV)

When the SON (servo-on) signal turns ON, the servo turns on. As the controller subsequently enters a ready state, this signal turns ON.

This signal turns OFF when the servo is turned off upon turning OFF of the SON signal.

This signal is linked to the LED (green light) on the front panel of the controller.

■ Alarm Signal (\*ALM)

This signal turns OFF when the controller's protective circuit (function) has actuated following an alarm detection and the basic cutoff procedure has been implemented as a result.

The signal will turn ON if the RES (reset) signal is turned ON after the cause of the alarm has been removed (except when the alarm relates to a cold-start level error).

When an alarm is detected, a red LED light will illuminate on the front panel of the controller. A green LED remains on while the controller is operating normally.



Caution:

- Identify the cause of each alarm and remove the cause before restarting the controller.  
You can check alarm codes using the teaching pendant or PC software. The controller can store data of up to 16 most recent alarms. This alarm history data will be retained even after the power is cut off.  
Each alarm record is displayed with the time it was generated, so you can check which alarm occurred when.
- For details on alarm history, refer to 6.3, "Alarms, Causes and Actions."

## 4.2.2 Setting Parameters Required for Operation

The following parameters must always be set prior to every operation.  
(These parameters are all you need to set to perform operations that only involve positioning.)

### (1) Electronic gear

User Parameter Nos. 65 and 66 (Electronic gear numerator and denominator)

Name	Symbol	Unit	Input range	Default (reference)
Electronic gear numerator	CNUM	-	1 ~ 4096	200
Electronic gear denominator	CDEN	-	1 ~ 4096	15

These parameters are used to determine the unit travel distance of the actuator per one pulse in input command pulse train.

Unit travel distance of linear-motion axis = Minimum travel unit (1, 0.1, 0.01 mm, etc.)/pulse

Unit travel distance of rotational axis = Minimum travel unit (1, 0.1, 0.01 deg, etc.)/pulse

### ■ Calculation Formula for Electronic Gear

Linear-motion axis

$$\frac{\text{Electronic gear numerator (CNUM)}}{\text{Electronic gear denominator (CDEN)}} = \frac{\text{Encoder pulses (pulses/rev)}}{\text{Ball screw lead length (mm/rev)}} \times \text{Unit travel distance (mm/pulse)}$$

Rotational axis

$$\frac{\text{Electronic gear numerator (CNUM)}}{\text{Electronic gear denominator (CDEN)}} = \frac{\text{Encoder pulses (pulses/rev)}}{360 \text{ (deg/rev)} \times \text{Gear ratio of rotational axis}} \times \text{Unit travel distance (deg/pulse)}$$

#### Reference

The actuator speed is calculated as follows:

Speed = Unit travel distance x Input pulse frequency (Hz)

Take note that if the unit travel distance is too small, the actuator may not be able to reach the maximum speed.

#### List of encoder pulses and leads by model

Actuator type	Encoder pulse count (Pulse/rev)	Lead
SA4C/SA5C/SA6C/SA4D/SA5D/SA6D SS4D/SS5D/SS6D/SA4R/SA5R/SA6R RA3C/RA4C/RA3D/RA4D/RA3R/RA4R RGS3C/RGS4C/RGS3D/RGS4D/RGD3C RGD4C/RGD3D/RGD4D A4R/A5R/A6R	800	Check the lead indicated on the front panel of the controller.

■ Calculation Example

Operate an actuator with a ball screw lead of 6 mm equipped with an encoder of 800 pulses/rev, at a unit travel distance to 0.1 mm (1/10).

\* Encoder pulses are 800 pulses/rev for all RCP2 models.

$$\frac{\text{Electronic gear numerator (CNUM)}}{\text{Electronic gear denominator (CDEN)}} = \frac{\text{Encoder pulses (pulses/rev)}}{\text{Ball screw lead length (mm/rev)}} \times \text{Unit travel distance (mm/pulse)}$$

$$= \frac{800}{6} \times \frac{1}{10} = \frac{40}{3}$$

The electronic gear numerator (CNUM) and electronic gear denominator (CDEN) are 40 and 3, respectively. Based on these settings, the travel distance per one pulse in input command pulse train is calculated as 0.1 mm.

⚠ Caution:

- Set both the electronic gear numerator (CNUM) and electronic gear denominator (CDEN) as integers not exceeding 4,096, by reducing them as much as possible with a common divisor. Also, CNUM and CDEN must satisfy the relational expression specified below.

$$2^{31} \geq \frac{\text{Stroke length (mm)}}{\text{Ball screw lead length (mm/rev)}} \times \text{Encoder pulses (Pulse)} \times (\text{CNUM})$$

$$2^{31} \geq \frac{\text{Stroke length (mm)}}{\text{Ball screw lead length (mm/rev)}} \times \text{Encoder pulses (Pulse)} \times (\text{CDEN})$$

- Do not set a minimum travel unit smaller than the encoder resolution.

$$\text{Encoder resolution for linear-motion axis (mm/pulse)} = \frac{\text{Ball screw lead length (mm/rev)}}{\text{Encoder pulses (pulses/rev)}}$$

$$\text{Encoder resolution for rotational axis (deg/pulse)} = \frac{360 (\text{deg/rev}) \times \text{Gear ratio of rotational axis}}{\text{Encoder pulses (pulses/rev)}}$$

The actuator will not move unless enough command pulses accumulate to reach or exceed the encoder resolution.

## (2) Command Pulse Mode

User Parameter No. 63 (Command-pulse input mode)

Name	Symbol	Unit	Input range	Default (reference)
Command-pulse input mode	MOD	-	0 ~ 2	1

Set a pulse-train input pattern for command pulse input (PP•/PP, NP•/NP).

\* The setting of positive logic or negative logic is explained in (3), "Input Polarity in the Command Pulse Mode."

Command-pulse input pattern	Input terminal	Forward	Reverse	Setting
Negative logic	Forward pulse train	PP • /PP		2
	Reverse pulse train	NP • /NP		
	Forward pulse trains indicate motor revolutions in the positive direction, while reverse pulse trains indicate motor revolutions in the reverse direction.			
	Pulse train	PP • /PP		1
	Sign	NP • /NP		
	Command pulses indicate motor revolutions, while the sign of the command indicates the rotating direction.			
	Phase-A/B pulse train	PP • /PP		0
NP • /NP				
Phase-A/B x4 pulses of 90° phase difference indicate both revolutions and rotating direction.				
Positive logic	Forward pulse train	PP • /PP		2
	Reverse pulse train	NP • /NP		
	Pulse train	PP • /PP		1
	Sign	NP • /NP		
	Phase-A/B pulse train	PP • /PP		0
NP • /NP				

## (3) Input Polarity in the Command Pulse Mode

User Parameter No. 64 (Polarity in command-pulse input mode)

Name	Symbol	Unit	Input range	Default (reference)
Polarity in command-pulse input mode	POLE	-	0 ~ 1	0

Setting

Positive logic: 0

Negative logic: 1

**⚠ Warning:** The magnetic-pole phase is detected when the servo is turned on for the first time after turning on the power. The actuator normally moves by approx. 0.5 to 2 mm due to this detection operation, although the specific distance will vary depending on the ball screw lead.

(On rare occasions where the actuator position at which the power is turned on is not ideal, the actuator may move by around one half the ball screw lead.)

If the power is turned on when the actuator is positioned near a mechanical end, the detection operation may cause the actuator to contact the mechanical end and reverse.

Pay due attention not to cause the work or hand to contact any surrounding object and sustain damage as a result.

## 4.2.3 Timings after Power On

- Steps from Initial Startup to Actuator Adjustment

- [1] Confirm that the slider or rod is not contacting a mechanical end or that the work is not contacting any peripheral equipment.
- [2] Cancel the emergency stop or connect the motor drive power.
- [3] Supply the 24-VDC I/O power: PIO connector pins 1 and 2.
- [4] Supply the 24-VDC controller power: 24-V and 0-V terminals on the power-supply terminal block.
- [5] Set the minimum required parameters. Refer to 4.2.2, "Setting Parameters Required for Operation."  
Reference To temporarily disable the servo-on input because the PLC is not yet ready to accept the input, change the value of Parameter No. 21 (Servo-on input disable selection) to "1."
- [6] Input a servo-on signal from the PLC (if the servo-on input is enabled).
- [7] Input a homing signal from the PLC.
- [8] Input position command pulses from the PLC.

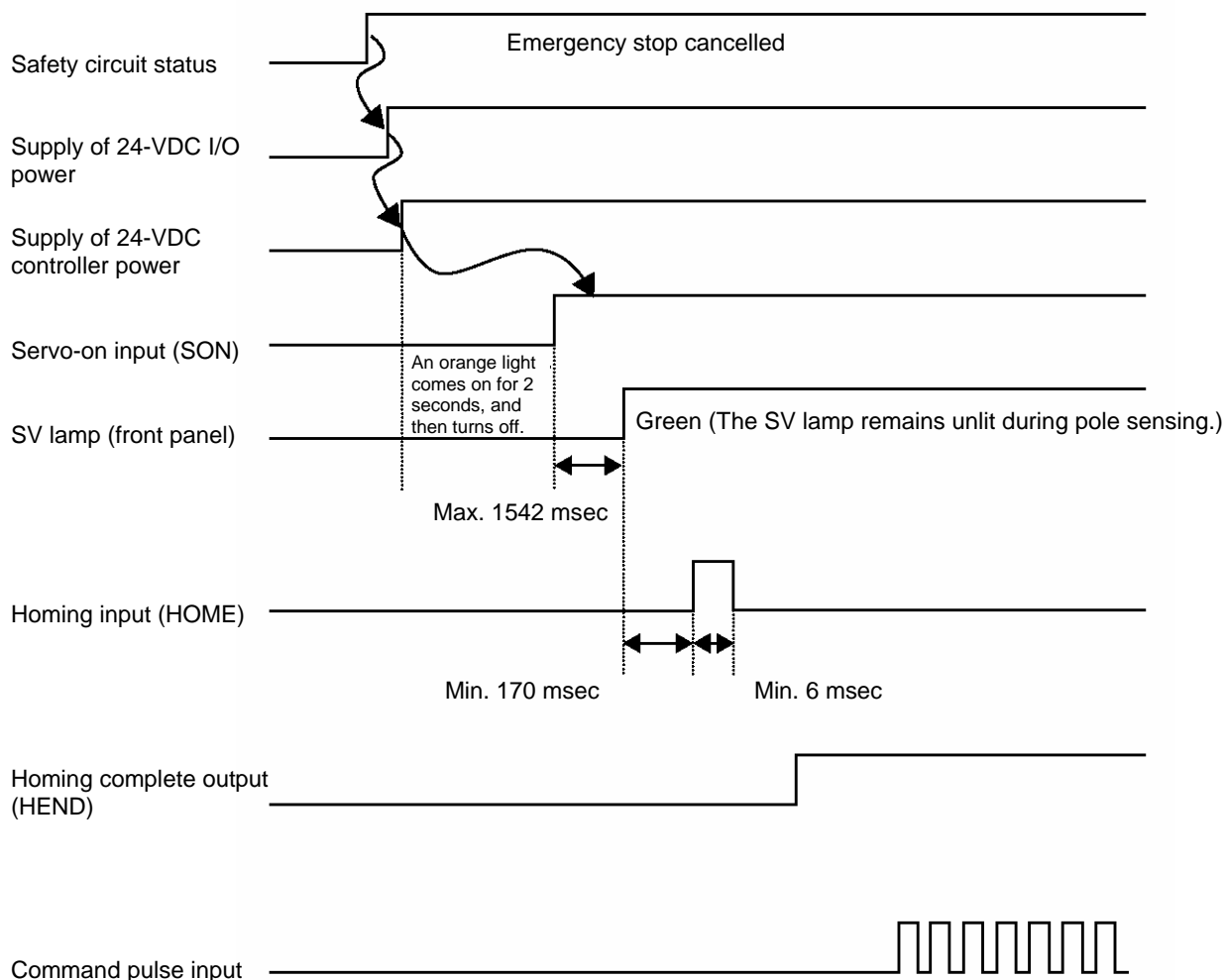

\* If Parameter No. 21 (Servo-on input disable selection) is set to "1," a servo-on signal need not be input.

⚠ Caution: In the "Emergency stop actuated → Turn on the power → Servo-on input → Cancel the emergency stop" sequence, the servo will turn on up to 1542 msec after the emergency stop is cancelled.

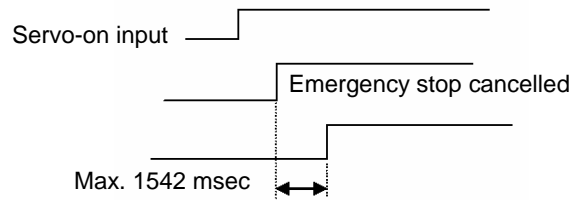

## 4.3 Push Type

Use the PIO pattern of this type if you wish to perform position control and push-motion operation using pulse train input from a PLC.

Set User Parameter No. 25 (PIO pattern selection) to "1."

### 4.3.1 Explanation of I/O Signals

Pin No.	Signal	Name	Remarks
1	24 V	External 24 V	
2	0 V	External ground	If the controller is used in the open collector mode, also use this pin for the COMMON signal for command pulses as well as the 0V signal for the controller's control power.
3	IN0	SON	Servo-on signal
4	IN1	TL	Torque-limit selection signal
5	IN2	HOME	Homing signal
6	IN3	RES/DCLR	Reset signal/deviation-counter clear signal
7	OUT0	SV	Servo-on output
8	OUT1	INP/TLR	Positioning complete signal/torque limit signal
9	OUT2	HEND	Homing complete signal
10	OUT3	*ALM	Alarm signal
11	/PP	Command pulse	
12	PP	Command pulse	Not connected if the controller is used in the open collector
13	/NP	Command pulse	mode.
14	NP	Command pulse	Not connected if the controller is used in the open collector mode.

#### ■ Servo-on Command Input (SON)

The servo remains on while this signal is ON.

The actuator can be operated while the SON signal is ON.

While this signal is OFF, the actuator does not operate even when the controller power is supplied.

If the SON signal is turned OFF while the actuator is operating, the actuator will decelerate at the forced-stop torque until it stops. After the actuator stops, the servo will turn off and the motor will enter a free-run state.

At this time, the function specified by the applicable parameter (electromagnetic brake) becomes active.

#### ■ Reset Signal Input (RES)

This signal resets the alarms currently detected by the controller.

You can turn the RES signal ON to reset the alarms currently detected by the controller.



**Caution:** This signal cannot reset cold-start level alarms. Identify the cause of each alarm and remove the cause before restarting the controller.

#### ■ Deviation-counter Clear Signal (DCLR)

While the TL signal is ON, the RES signal functions as the deviation-counter clear signal (DCLR).

The deviation counter is cleared continuously while this signal is ON.

Upon completion of push-motion operation, you can clear the deviation counter by inputting this signal.

## ■ Torque-limit Selection Signal (TL)

This signal limits the motor torque.

While this signal is ON, the actuator thrust (motor torque) is limited to the torque set in User Parameter No. 57 (Torque limit).

- |  |
|--|
| <p> <b>Caution:</b></p> <ul style="list-style-type: none"><li>● Do not turn the TL signal OFF while it is ON.</li><li>● Excessive deviation (standing pulses) may generate while torque is limited (while the TL signal is ON) (for example, when the actuator receives load and is prevented from moving just like in push-motion operation).<br/>If the TL signal is turned OFF in this condition, the controller will instantly start controlling the actuator at the maximum torque and the actuator may move suddenly or run out of control.</li></ul> |
|--|

This signal can be disabled using User Parameter No. 61 (Torque-limit command input). Disable the TL signal if it is not used.

## ■ Homing Signal (HOME)

This command signal is used to perform homing automatically.

The homing command is processed at the leading edge (ON edge) of the HOME signal to cause the actuator to return to its home automatically.

When the homing is completed, the HEND (homing complete) output signal turns ON.

Program the host controller (PLC) so that its current-value register will be reset to the home ("0" will be input to the register) by the current-value preset function, etc., upon turning ON of the HOME signal.

\* This signal is always enabled as long as the servo is on.

\* Even after homing has been performed once, homing can be performed again by turning the HOME signal ON.

- |   |
|---|
| <p> <b>Caution:</b></p> <ul style="list-style-type: none"><li>● The HOME signal is given priority over pulse train commands. Even while the actuator is moving under a pulse train command, it will start moving to the home once the HOME signal is turned ON.</li><li>● The HOME signal is processed only at its leading edge (ON edge).</li><li>● If the SON signal turns OFF or an alarm is detected during homing, the homing operation will stop. If the servo turns off, the homing command will be cancelled even if the HOME signal is still ON. To perform homing again, turn the HOME signal OFF, and then turn it back ON.</li><li>● The actuator can be operated without using this function. If this function is not used, however, all management actions over position data will be left to the host controller.<br/>In this case, take necessary measures to prevent an over-stroke error, such as not sending pulse commands exceeding the effective stroke, or providing external limit switches or other devices for detecting stroke ends to forcibly stop the actuator upon detection of a stroke end.</li><li>● This controller has a command pulse counter. After homing, the controller increments/decrements command pulses and performs positioning based on command pulse data.<br/>However, the command pulse counter cannot be used if this function is not used. Without this function, the position where the actuator is currently stopped is used as the origin and the actuator will move from there by the number of pulses input (incremental movement). If incremental movement is repeated, positioning errors generating in individual positioning operations will accumulate and the actuator may end up not stopping at the final target position. To prevent this problem, periodically execute homing from the host controller or take other appropriate measures.</li></ul> |
|---|

■ Command Pulse Input

Command pulses can be input in the open collector mode (60 kpps) or differential line driver mode (200 kpps). You can select a desired input pattern of command pulses from 90° phase-difference (phase-A/B x4) signal, pulse train + forward/reverse signal, and forward pulse/reverse pulse. The positive logic or negative logic can be selected for each of these patterns.

⚠ Caution:

- The actuator moves in the negative direction (the motor runs in the forward direction) when forward pulses are input, and moves in the positive direction (the motor runs in the reverse direction) when reverse pulses are input. (These directions are reversed if the actuator is of motor reversing type.)
- When determining the forward/reverse directions, pay attention to the host controller setting as well as the PP•/PP and NP•/NP connection.
- For actuator accelerations/decelerations, set values not exceeding the rated acceleration/deceleration of the actuator. (The rated acceleration/deceleration of each actuator is specified in the actuator's catalog.)

\* The motor direction is determined based on CCW representing the forward direction when viewed from the load-end of the shaft.

- You can set one of six command pulse patterns in the command-pulse input mode.

Command-pulse input pattern		Input terminal	Forward	Reverse	
Negative logic	Forward pulse train	PP • /PP			
	Reverse pulse train	NP • /NP			
	Forward pulse trains indicate motor revolutions in the positive direction, while reverse pulse trains indicate motor revolutions in the reverse direction.				
	Pulse train	PP • /PP			
	Sign	NP • /NP	Low	High	
	Command pulses indicate motor revolutions, while the sign of the command indicates the rotating direction.				
	Phase-A/B pulse train	PP • /PP			
		NP • /NP			
Phase-A/B x4 pulses of 90° phase difference indicate both revolutions and rotating direction.					
Positive logic	Forward pulse train	PP • /PP			
	Reverse pulse train	NP • /NP			
	Pulse train	PP • /PP			
	Sign	NP • /NP	High	Low	
	Phase-A/B pulse train	PP • /PP			
		NP • /NP			

## ■ Positioning Complete Signal (INP)

This signal turns ON when the deviation in the deviation counter (standing pulses) is within the positioning band. It remains OFF while the servo is off.

-  Caution:
- This signal turns ON when the servo is turned on (to perform positioning at the present position).
  - This signal turns ON simply due to accumulation of deviation (standing pulses). Therefore, setting an excessively wide positioning band in the applicable position control parameter will cause the INP signal to turn ON once the actuator enters the positioning band during low-speed operation (before positioning is completed).

## ■ Torque Limiting Signal (TLR)

This signal turns ON when the specified torque limit is reached in the torque limiting mode.

While the TL (torque-limit selection) signal is ON, this signal will turn ON if the actuator thrust (motor torque) reaches the torque limit set by the torque limit parameter.

This signal will turn OFF once the motor torque drops to below the specified limit.

## ■ Homing Complete Signal (HEND)

This signal turns ON after homing has completed and the coordinate system has been established.

It turns ON upon completion of homing initiated by the HOME signal or a command from the teaching pendant or PC software.

This signal turns OFF once the servo turns off. Perform homing again after the servo has turned off.

-  Caution:
- The software stroke limits set by the corresponding actuator parameters are effective only while this signal is ON.
  - The actuator can be operated without using this function. In this case, however, take necessary measures, such as not sending pulse commands exceeding the effective stroke, or providing external limit switches for detecting stroke ends to forcibly stop the actuator upon detection of a stroke end.

## ■ Servo-on Output Signal (SV)

When the SON (servo-on) signal turns ON, the servo turns on. As the controller subsequently enters a ready state, this signal turns ON.

This signal turns OFF when the servo is turned off upon turning OFF of the SON signal.

This signal is linked to the LED (green light) on the front panel of the controller.

■ Alarm Signal (ALM)

This signal turns OFF when the controller's protective circuit (function) has actuated following an alarm detection and the basic cutoff procedure has been implemented as a result.

The signal will turn ON if the RES (reset) signal is turned ON after the cause of the alarm has been removed (except when the alarm relates to a cold-start level error).

When an alarm is detected, a red LED light will illuminate on the front panel of the controller. A green LED remains on while the controller is operating normally.



Caution:

- Identify the cause of each alarm and remove the cause before restarting the controller.  
You can check alarm codes using the teaching pendant or PC software. The controller can store data of up to 16 most recent alarms. This alarm history data will be retained even after the power is cut off.  
Each alarm record is displayed with the time it was generated, so you can check which alarm occurred when.
- For details on alarm history, refer to 6.3, "Alarms, Causes and Actions."

## 4.3.2 Setting Parameters Required for Operation

The following parameters must always be set prior to every operation.  
(These parameters are all you need to set to perform operations that only involve positioning.)

### (1) Electronic gear

User Parameter Nos. 65 and 66 (Electronic gear numerator and denominator)

Name	Symbol	Unit	Input range	Default (reference)
Electronic gear numerator	CNUM	-	1 ~ 4096	200
Electronic gear denominator	CDEN	-	1 ~ 4096	15

These parameters are used to determine the unit travel distance of the actuator per one pulse in input command pulse train.

Unit travel distance of linear-motion axis = Minimum travel unit (1, 0.1, 0.01 mm, etc.)/pulse

Unit travel distance of rotational axis = Minimum travel unit (1, 0.1, 0.01 deg, etc.)/pulse

#### ■ Calculation Formula for Electronic Gear

Linear-motion axis

$$\frac{\text{Electronic gear numerator (CNUM)}}{\text{Electronic gear denominator (CDEN)}} = \frac{\text{Encoder pulses (pulses/rev)}}{\text{Ball screw lead length (mm/rev)}} \times \text{Unit travel distance (mm/pulse)}$$

Rotational axis

$$\frac{\text{Electronic gear numerator (CNUM)}}{\text{Electronic gear denominator (CDEN)}} = \frac{\text{Encoder pulses (pulses/rev)}}{360 \text{ (deg/rev)} \times \text{Gear ratio of rotational axis}} \times \text{Unit travel distance (deg/pulse)}$$

#### Reference

The actuator speed is calculated as follows:

Speed = Unit travel distance x Input pulse frequency (Hz)

Take note that if the unit travel distance is too small, the actuator may not be able to reach the maximum speed.

#### List of encoder pulses and leads by model

Actuator type	Encoder pulse count (Pulse/rev)	Lead
SA4C/SA5C/SA6C/SA4D/SA5D/SA6D SS4D/SS5D/SS6D/SA4R/SA5R/SA6R RA3C/RA4C/RA3D/RA4D/RA3R/RA4R RGS3C/RGS4C/RGS3D/RGS4D/RGD3C RGD4C/RGD3D/RGD4D A4R/A5R/A6R	800	Check the lead indicated on the front panel of the controller.

■ Calculation Example

Operate an actuator with a ball screw lead of 6 mm equipped with an encoder of 800 pulses/rev, at a unit travel distance to 0.1 mm (1/10).

\* Encoder pulses are 800 pulses/rev for all RCP2 models.

$$\frac{\text{Electronic gear numerator (CNUM)}}{\text{Electronic gear denominator (CDEN)}} = \frac{\text{Encoder pulses (pulses/rev)}}{\text{Ball screw lead length (mm/rev)}} \times \text{Unit travel distance (mm/pulse)}$$

$$= \frac{800}{6} \times \frac{1}{10} = \frac{40}{3}$$

The electronic gear numerator (CNUM) and electronic gear denominator (CDEN) are 40 and 3, respectively. Based on these settings, the travel distance per one pulse in input command pulse train is calculated as 0.1 mm.

⚠ Caution:

- Set both the electronic gear numerator (CNUM) and electronic gear denominator (CDEN) as integers not exceeding 4,096, by reducing them as much as possible with a common divisor. Also, CNUM and CDEN must satisfy the relational expression specified below.

$$2^{31} \geq \frac{\text{Stroke length (mm)}}{\text{Ball screw lead length (mm/rev)}} \times \text{Encoder pulses (Pulse)} \times (\text{CNUM})$$

$$2^{31} \geq \frac{\text{Stroke length (mm)}}{\text{Ball screw lead length (mm/rev)}} \times \text{Encoder pulses (Pulse)} \times (\text{CDEN})$$

- Do not set a minimum travel unit smaller than the encoder resolution.

$$\text{Encoder resolution for linear-motion axis (mm/pulse)} = \frac{\text{Ball screw lead length (mm/rev)}}{\text{Encoder pulses (pulses/rev)}}$$

$$\text{Encoder resolution for rotational axis (deg/pulse)} = \frac{360 \text{ (deg/rev)} \times \text{Gear ratio of rotational axis}}{\text{Encoder pulses (pulses/rev)}}$$

The actuator will not move unless enough command pulses accumulate to reach or exceed the encoder resolution.

## (2) Command Pulse Mode

User Parameter No. 63 (Command-pulse input mode)

Name	Symbol	Unit	Input range	Default (reference)
Command-pulse input mode	MOD	-	0 ~ 2	1

Set a pulse-train input pattern for command pulse input (PP•/PP, NP•/NP).

\* The setting of positive logic or negative logic is explained in (3), "Input Polarity in the Command Pulse Mode."

Command-pulse input pattern	Input terminal	Forward	Reverse	Setting	
Negative logic	Forward pulse train	PP • /PP			2
	Reverse pulse train	NP • /NP			
	Forward pulse trains indicate motor revolutions in the positive direction, while reverse pulse trains indicate motor revolutions in the reverse direction.				
	Pulse train	PP • /PP			1
	Sign	NP • /NP			
	Command pulses indicate motor revolutions, while the sign of the command indicates the rotating direction.				
	Phase-A/B pulse train	PP • /PP			0
		NP • /NP			
Phase-A/B x4 pulses of 90° phase difference indicate both revolutions and rotating direction.					
Positive logic	Forward pulse train	PP • /PP			2
	Reverse pulse train	NP • /NP			
	Pulse train	PP • /PP			1
	Sign	NP • /NP			
	Phase-A/B pulse train	PP • /PP			0
		NP • /NP			

## (3) Input Polarity in the Command Pulse Mode

User Parameter No. 64 (Polarity in command-pulse input mode)

Name	Symbol	Unit	Input range	Default (reference)
Polarity in command-pulse input mode	POLE	-	0 ~ 1	0

Setting

Positive logic: 0

Negative logic: 1

 **Warning:** The magnetic-pole phase is detected when the servo is turned on for the first time after turning on the power. The actuator normally moves by approx. 0.5 to 2 mm due to this detection operation, although the specific distance will vary depending on the ball screw lead.

(On rare occasions where the actuator position at which the power is turned on is not ideal, the actuator may move by around one half the ball screw lead.)

If the power is turned on when the actuator is positioned near a mechanical end, the detection operation may cause the actuator to contact the mechanical end and reverse.

Pay due attention not to cause the work or hand to contact any surrounding object and sustain damage as a result.

## 4.3.3 Timings after Power On

- Steps from Initial Startup to Actuator Adjustment

- [1] Confirm that the slider or rod is not contacting a mechanical end or that the work is not contacting any peripheral equipment.
- [2] Cancel the emergency stop or connect the motor drive power.
- [3] Supply the 24-VDC I/O power: PIO connector pins 1 and 2.
- [4] Supply the 24-VDC controller power: 24-V and N terminals on the power-supply terminal block.
- [5] Set the minimum required parameters. Refer to 4.2.2, "Setting Parameters Required for Operation."  
Reference To temporarily disable the servo-on input because the PLC is not yet ready to accept the input, change the value of Parameter No. 21 (Servo-on input disable selection) to "1."
- [6] Input a servo-on signal from the PLC (if the servo-on input is enabled).
- [7] Input a homing signal from the PLC.
- [8] Input position command pulses from the PLC.

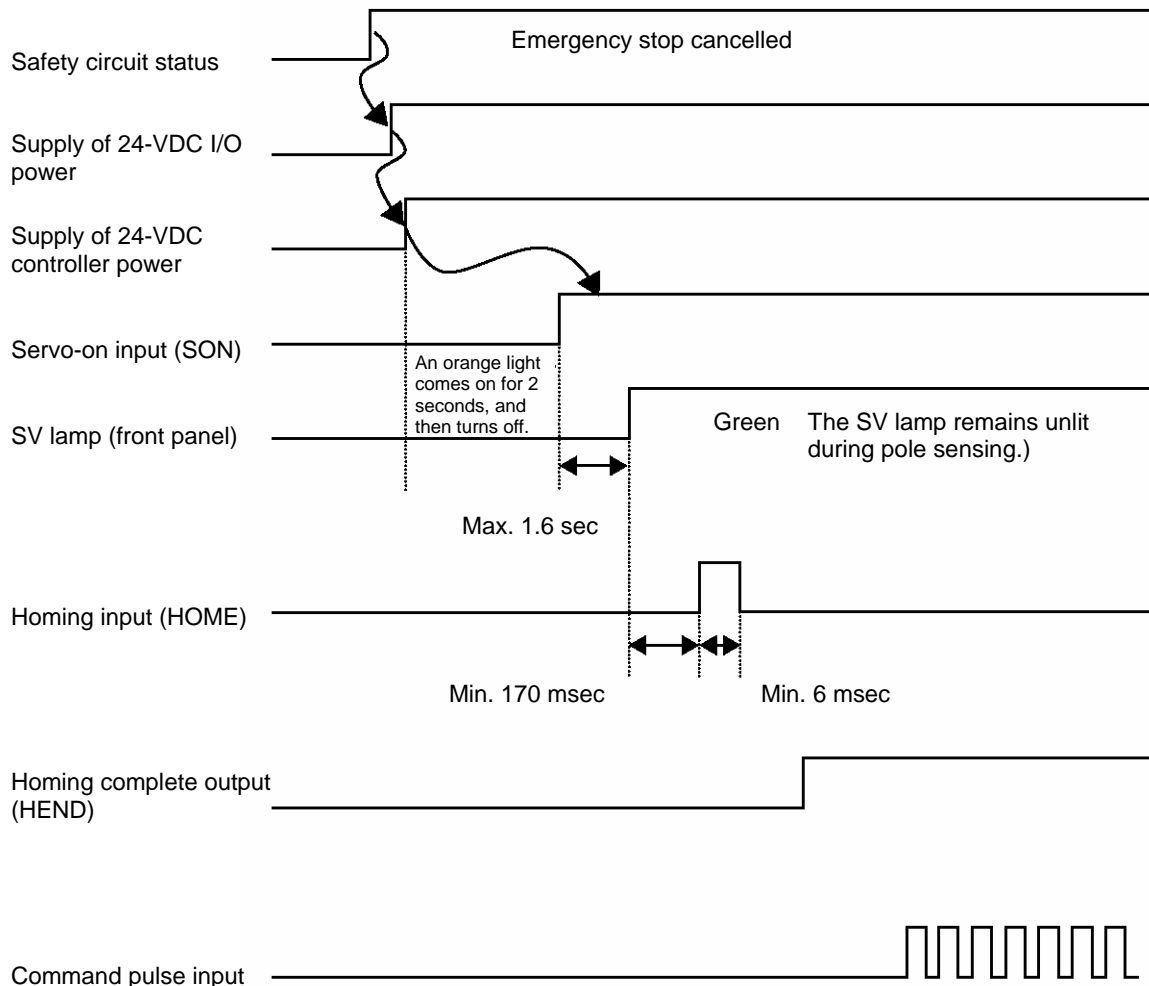

\* If Parameter No. 21 (Servo-on input disable selection) is set to "1," a servo-on signal need not be input.

⚠ Caution: In the "Emergency stop actuated → Turn on the power → Servo-on input → Cancel the emergency stop" sequence, the servo will turn on up to 1542 msec after the emergency stop is cancelled.

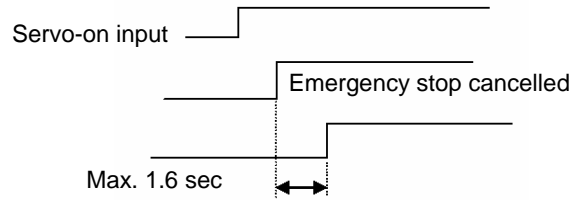

## 5. Parameter Settings

### 5.1 Parameter List

The parameters are classified into the following four types depending on their function:

Types:

- a: Parameter relating to actuator stroke range
- b: Parameter relating to actuator operating characteristics
- c: Parameter relating to external interface
- d: Servo gain adjustment

No.	Type	Symbol	Name	Unit	Factory default
3	a	LIMM	Soft limit + side	mm	Effective length of the actuator
4	a	LIML	Soft limit – side	mm	Effective length of the actuator
5	a	ORG	Home direction [0: Reverse / 1: Forward]	-	(As specified at the time of order)
7	d	PLGO	Servo gain number	-	6
9	b	ACMD	Default acceleration/deceleration	G	Set individually in accordance with the actuator characteristics.
10	b	INP	Default positioning band (in-position)	mm	Set individually in accordance with the actuator characteristics.
13	b	ODPW	Current-limiting value during homing	%	100
16	c	BRSL	SIO communication speed	bps	38400
17	c	RTIM	Minimum delay time for slave transmitter activation	msec	5
18	c	LS	Home sensor input polarity [0: None / 1: Contact a / 2: Contact b]	-	0
21	c	SON	Servo-on input [0: Enable / 1: Disable]	-	0
22	a	OFST	Home offset	mm	Set individually in accordance with the actuator characteristics.
25	c	IOPN	PIO pattern selection	-	0 [Standard type]
28	b	PHSP	Default direction of excited phase signal detection [0: Reverse / 1: Forward]	-	0
29	b	PHSP	Excited phase signal detection time	msec	128
30	b	PHSP	Pole sensing type [0: Current suppression / 1: Distance suppression]	-	1
31	d	VLPG	Speed loop proportional gain	-	Set individually in accordance with the actuator characteristics.
32	d	VLPT	Speed loop integral gain	-	Set individually in accordance with the actuator characteristics.
33	d	TRQF	Torque filter time constant	-	Set individually in accordance with the actuator characteristics.
35	b	SAFV	Safety speed	mm/sec	100
40	c	HOME	Homing input [0: Enable / 1: Disable]	-	0 [Enable]
42	b	ENBL	Enable function [0: Enable / 1: Disable]	-	1 [Disable]
43	b	HMC	Home check sensor input polarity [1: Contact a / 2: Contact b]	-	Set individually in accordance with the actuator characteristics.
45	c	SIVM	Silent interval multiplication factor	-	0 [Multiplication factor disabled]
52	c	HSTP	Default acceleration/deceleration mode	-	0 [Trapezoid]
54	d	CLPF	Current control band number	-	4
55	b	PLPF	Primary filter time constant for position command	msec	0
57	b	TQLM	Torque limit	%	70
58	c	SDCR	Clear deviation at servo off/alarm stop [0: Disable / 1: Enable]	-	1 [Enable]
59	b	FSTP	Monitor error while limiting torque [0: Disable / 1: Enable]	-	1 [Enable]
60	c	DCLR	Deviation-counter clear input [0: Enable / 1: Disable]	-	0 [Enable]

No.	Type	Symbol	Name	Unit	Factory default
61	c	TL	Torque-limit command input [0: Enable / 1: Disable]	-	0 [Enable]
62	b	CPR	Pulse count direction [0: Forward / 1: Reverse]	-	Set individually in accordance with the actuator characteristics.
63	c	MOD	Command-pulse input mode	-	1 [Pulse train + Sign]
64	c	POLE	Polarity in command-pulse input mode [0: Positive / 1: Negative]	-	0 [Positive logic]
65	b	CNUM	Electronic gear numerator	-	4096 [Numerator of command pulse multiplier]
66	b	CDEN	Electronic gear denominator	-	4096 [Denominator of command pulse multiplier]
71	d	PLFG	Position feed-forward gain	-	0
77	b	LEAD	Ball screw lead [mm]	-	Set individually in accordance with the actuator characteristics.

## 5.2 Detail Explanation of Parameters

If you have changed any parameter, be sure to restart the controller via a software reset or reconnect the controller power.

### 5.2.1 Parameters Relating to Actuator Stroke Range

- Soft Limits (No. 3 LIMM) (No.4 LIML)

Set the + soft limit in parameter No. 3 and – soft limit in parameter No. 4.

Both parameters have been set to the effective actuator length at the factory. Change the parameter settings if necessary, such as when an obstacle is present and collision between the actuator and obstacle must be prevented or when the actuator must be operated beyond the effective length.

Exercise due caution when setting these parameters, as wrong settings will cause collision with the mechanical end.

The minimum setting unit is 0.01 mm.

(Note) To change these parameters, set values corresponding to positions that are 0.3 mm wider than the desired effective range.

Example) Set the effective range to between 0 and 80 mm  
 Parameter No. 3 (+ side): 80.3  
 Parameter No. 4 (– side): -0.3

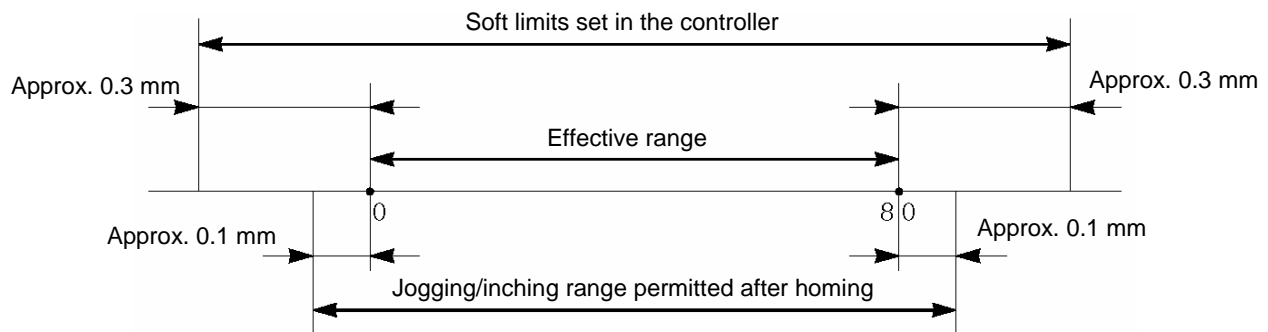

- Home Direction (No.5 ORG)

If not specified by the user, the home direction is set to the motor side before shipment.

If you must change the home direction after the actuator has been assembled to your equipment, change the setting of parameter No. 5.

Also change the parameters for home offset, soft limits and default direction of excited phase signal detection, if necessary.

⚠ Caution: Rod-type actuators do not permit reversing of the home direction.  
 Note that if the home direction is reversed, all the entered position data will be cleared.

- Home Offset (No. 22 OFST)

Parameter No. 22 has been set to an optimal value at the factory so that the distance from the mechanical end to home will remain constant.

The minimum setting unit is 0.01 mm.

This parameter can be adjusted in the following conditions:

- [1] Align the actuator's home with the mechanical home on the equipment after the actuator has been assembled to the equipment.
- [2] Set the home position again after reversing the factory-set home direction.
- [3] Correct the minor position deviation that has generated after the actuator was replaced.



Caution: If you have changed the home offset, the soft limit parameters must also be reviewed.

## 5.2.2 Parameters Relating to Actuator Operating Characteristics

- **Default Acceleration/Deceleration (No. 9 ACMD)**

The factory setting is the rated acceleration/deceleration of the actuator.

The value of this parameter sets the acceleration/deceleration to be applied in jogging operation performed on the teaching pendant or using the PC software.

To decrease the default acceleration/deceleration from the rated acceleration/deceleration, change the value set in Parameter No. 9.

- **Default Positioning Band (In-position) (No. 10 INP)**

The factory setting is "0.01" mm, which is set in Parameter No. 10.

This value is used to determine if positioning has completed. With a controller of pulse-train input type, the positioning complete signal (INP) will turn ON when the deviation in the deviation counter (standing pulses) is within the range set in this parameter. Increasing the value of this parameter excessively may cause the positioning complete signal (INP) to be output before positioning is completed.

- **Current-limiting Value during Homing (No. 13 ODPW)**

Before shipment, this parameter is set to a current level appropriate for the standard specification of the actuator.

Since the default setting need not be changed in normal conditions of use, the customer is advised not to change the parameter.

## ● Default Direction of Excited Phase Signal Detection

The excited phase is detected when the servo is turned on for the first time after turning on the power. This parameter defines the direction of this detection.

This parameter need not be changed in normal conditions of use. However, if the actuator is contacting a mechanical end or any obstacle when the power is turned on and cannot be moved by hand, change the direction of detection to one in which the motor can be driven easily.

To do this, set the value of Parameter No. 28 to either "0" or "1." If the direction of detection is to be the same as the home direction, specify the same value currently set in Parameter No. 5, "Home direction."

To set the direction opposite to the home direction, specify the value different from the one currently set in Parameter No. 5, "Home direction."

(Example 1) The power is turned on when the slider is contacting the bottom mechanical end in a configuration where the motor is positioned at the top.

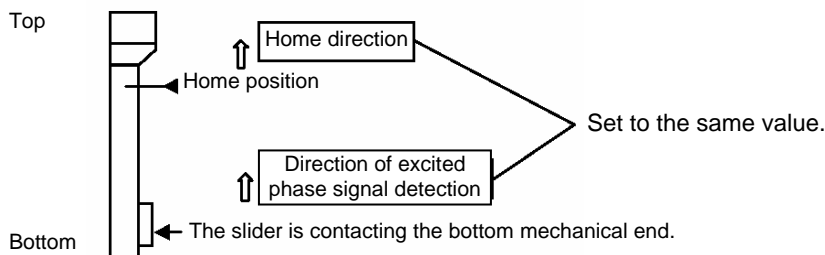

(Example 2) The power is turned on when the slider is contacting the bottom mechanical end in a configuration where the motor is positioned at the bottom.

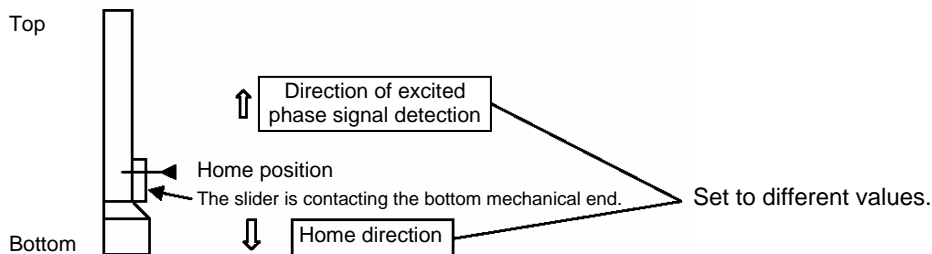

## ● Excited Phase Signal Detection Time

The excited phase is detected when the servo is turned on for the first time after turning on the power. This parameter defines the time of this detection.

Before shipment, this parameter is set to a detection time appropriate for the standard specification of the actuator, and thus the setting need not be changed in normal conditions of use.

Should an excitation detection error or abnormal operation occur when the servo is turned on for the first time after turning on the power, you can try changing the detection time set in Parameter No. 29 as a possible countermeasure.

Before changing this parameter, contact IAI.

## ● Pole Sensing Type

The magnetic-pole phase is detected when the servo is turned on for the first time after turning on the power. The mode of this detection operation is defined in Parameter No. 30.

Since the default setting need not be changed in normal conditions of use, the customer is advised not to change the parameter.

Definition of settings: 0 (Current suppression mode)  
1 (Distance suppression mode)

The factory setting is "1" [Distance suppression mode].

- **Safety Speed (No. 35 SAFV)**

This parameter defines the feed speed to be applied in jogging operation performed on the teaching pendant or using the PC software.

The factory setting is "100" [mm/sec].

To change the speed, set an optimal value in Parameter No. 35.

Since the maximum speed is limited to 250 mm/sec, set the safety speed to below this level.

\* This parameter is invalid during pulse train control.

- **Torque Limit (No. 57 TQLM)**

The torque limit to be applied when the torque-limit selection signal (TL) is input is set in Parameter No. 57.

Setting unit: %

The maximum limit is 70% of the rating.

- **Error Monitor while Limiting Torque (No. 59 TRER)**

Whether to disable or enable error monitor when deviation pulses exceed the value set in the applicable internal parameter while torque is limited (the TL signal is ON), is set in Parameter No. 59.

	Setting
Disable (Do not monitor)	0
Enable (Monitor)	1

The factory setting is "1" [Enable].

- **Pulse Count Direction (No. 62 CPR)**

The motor direction with respect to the command pulse is set in Parameter No. 62.

	Setting
Count pulses in forward direction	0
Count pulses in reverse direction	1

The factory setting is different for each actuator.

- **Electronic Gear (No. 65 CNUM) (No. 66 CDEN)**

The electronic gear numerator and denominator are set in Parameter Nos. 65 and 66.

	Setting
Electronic gear numerator	200
Electronic gear denominator	15

These parameters are used to determine the unit travel distance of the actuator per one pulse in input command pulse train.

Unit travel distance of linear-motion axis = Minimum travel unit (1, 0.1, 0.01 mm, etc.)/pulse

Unit travel distance of rotational axis = Minimum travel unit (1, 0.1, 0.01 deg, etc.)/pulse

- **Enable Function (No. 42 ENBL)**

Whether to enable or disable the deadman switch function of an ANSI teaching pendant is defined in Parameter No. 42.

\* An ANSI teaching pendant is still to be developed.

	Setting
Enable (Use)	0
Disable (Do not use)	1

The factory setting is "1" [Disable].

- Home Check Sensor Input Polarity [No. 43 HMC]

Although standard actuators do not come with a home check sensor, this sensor can be installed as an option. This parameter need not be changed in normal conditions of use. If the customer wishes to change the home check mode after shipment, change the value set in Parameter No. 43.

Definition of settings: 0 (Standard specification; no sensor)  
 1 (Use the home check sensor, and the sensor polarity conforms to “contact a” logic)  
 2 (Use the home check sensor, and the sensor polarity conforms to “contact b” logic)

[Explanation of operation]

- [1] When a homing command is issued, the actuator moves until contacting the mechanical end, after which it reverses the direction and stops at the home position.
- [2] If a home check sensor signal has been detected by the time the actuator is stopped, the controller determines that the homing was completed successfully. If a home check sensor signal is not detected before the actuator stops, the controller recognizes “position deviation.” Accordingly, the controller generates a “home sensor not yet detected” error and outputs an alarm signal.

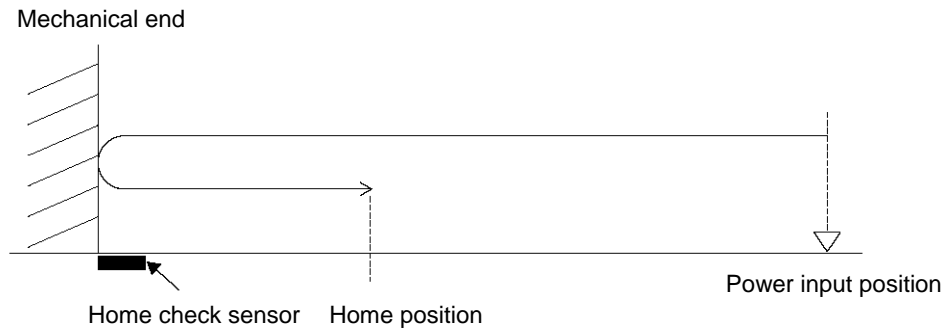

- Home Sensor Input Polarity (No. 18 AIOF)

The input polarity of the home sensor is defined in Parameter No. 18.

Since the current RCA actuators do not adopt the home sensor mode, the factory setting is “0” [No sensor].

This parameter is provided to support future extension of actuator function. The customer is advised not to change the setting.

Definition of settings: 0 (No sensor)  
 1 (Use the home sensor, and the sensor polarity conforms to “contact a” logic)  
 2 (Use the home sensor, and the sensor polarity conforms to “contact b” logic)

- Primary Filter Time Constant for Position Command (No. 55 PLPF)

Parameter No.	Unit	Input range	Default
55	msec	0 ~ 100	0

This parameter sets the time constant to be applied when the primary filter for position command is enabled by the acceleration/deceleration mode setting.

The setting unit for travel is “0.1” msec.

The greater the value set in this parameter, the longer the primary delay becomes.

\* If “0” is set, acceleration and deceleration do not reflect any primary delay.

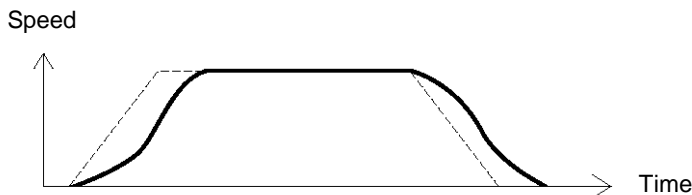

## 5.2.3 Parameters Relating to External Interface

- **PIO Pattern Selection (No. 25 IOPN)**

Parameter No. 25 is used to select a desired PIO operation pattern.

This is a basic operation parameter, so be sure to set it at the beginning.

Setting of Parameter No. 25	Features of PIO pattern
0	Standard type Use the PIO pattern of this type if you wish to perform position control using pulse train input from a PLC.
1	Push type Use the PIO pattern of this type if you wish to perform position control and push-motion control using pulse train input from a PLC.

The factory setting is "0" [Standard type].

- **Servo-on Input Disable Selection (No.21 SON)**

Parameter No. 21 is used to set whether enable or disable the servo-on input signal.

	Setting
Enable (Use)	0
Disable (Do not use)	1

The factory setting is "0" [Enable].

- **SIO Communication Speed (No. 16 BRSL)**

This parameter is not used with this controller. It applies to controllers of serial communication type.

If this parameter is set, it sets the communication speed to be used when the controller implements serial communication control via the PLC's communication module.

Set Parameter No. 16 to a value appropriate for the specification of the communication module.

9600, 19200, 38400 or 115200 bps can be selected as the communication speed.

The factory setting is "38400" bps.

- **Minimum Delay Time for Slave Transmitter Activation (No. 17 RTIM)**

This parameter is not used with this controller. It applies to controllers of serial communication type.

If this parameter is set, it defines the minimum delay before the controller's transmitter is activated following the completion of command reception, when the controller implements serial communication control via the PLC's communication module.

The factory setting is "5" msec. If the communication module specification exceeds 5 msec, set the required time in Parameter No. 17.

- **Silent Interval Multiplication Factor (No.45 SIVM)**

This parameter is not used with this controller. It applies to RS485 serial communication commands.

If this parameter is set, it defines the multiplication factor of silent interval time to be used for delimiter judgment in the RTU mode.

The factory setting is the communication time corresponding to 3.5 characters in accordance with the Modbus specification.

This parameter need not be changed in normal conditions of use where the actuator is operated using a PC or teaching pendant.

If the character sending interval exceeds the silent interval because the scan time of the PLC is not ideal, however, you can extend the silent interval time through Parameter No. 45.

The minimum setting unit is 1 (times), and the input range is 0 to 10. If "0" is set, it means that the silent interval multiplication factor is disabled.

- Default Acceleration/Deceleration Mode (No. 52 HSTP)

Parameter No.	Unit	Input range	Default
52	-	0 ~ 2	0

This parameter sets the acceleration/deceleration mode.

When "0" is set: Trapezoid

When "1" is set: Primary filter for position command

A primary delay is always reflected during movement. The travel corresponds to the specified pulses. Smooth acceleration and deceleration can be implemented even when the host controller has no acceleration/deceleration function or the number of command pulses changes suddenly.

The time constant is set in Parameter No. 55 (Filter time constant for position command).

If "0" is set, acceleration and deceleration do not reflect any primary delay.

Image diagram

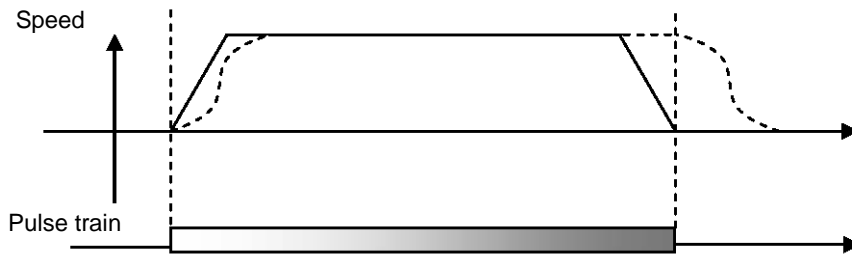

- Homing Input (No. 40 HOME)

Whether to disable or enable the homing input signal is set in Parameter No. 40.

	Setting
Enable (Use)	0
Disable (Do not use)	1

The factory setting is "0" [Enable].

- Clear Deviation at Servo Off/Alarm Stop (No. 58 SDCR)

Whether to disable or enable the deviation clear function when the servo is turned off or an alarm generates is set in Parameter No. 58.

	Setting
Disable (Do not clear)	0
Enable (Clear)	1

The factory setting is "1" [Enable].

- Deviation-counter Clear Input (No. 60 DCLR)

Whether to disable or enable the deviation-counter clear input is set in Parameter No. 60.

	Setting
Enable (Use)	0
Disable (Do not use)	1

The factory setting is "0" [Enable].

- Torque-limit Command Input (No. 61 TL)

Whether to disable or enable the torque-limit command input is set in Parameter No. 61.

	Setting
Enable (Use)	0
Disable (Do not use)	1

The factory setting is "0" [Enable].

- Command-pulse Input Mode (No. 63 MOD)

The command pulse pattern, selectable from six types, is set in Parameter No. 63.

	Command-pulse input pattern	Input terminal	Forward	Reverse	Setting
Negative logic	Forward pulse train	PP • /PP			2
	Reverse pulse train	NP • /NP			
	Forward pulse trains indicate motor revolutions in the positive direction, while reverse pulse trains indicate motor revolutions in the reverse direction.				
	Pulse train	PP • /PP			1
	Sign	NP • /NP	Low	High	
	Command pulses indicate motor revolutions, while the sign of the command indicates the rotating direction.				
	Phase-A/B pulse train	PP • /PP NP • /NP			0
Phase-A/B x4 pulses of 90° phase difference indicate both revolutions and rotating direction.					
Positive logic	Forward pulse train	PP • /PP			2
	Reverse pulse train	NP • /NP			
	Pulse train	PP • /PP			1
	Sign	NP • /NP	High	Low	
	Phase-A/B pulse train	PP • /PP NP • /NP			0

The factory setting is "1" [Pulse train + Sign].

- Polarity in Command-pulse Input Mode (No. 64 POLE)

The input polarity of command pulses is set in Parameter No. 64.

	Setting
Positive logic	0
Negative logic	1

The factory setting is "0" [Positive logic].

## 5.2.4 Servo Gain Adjustment

Since the servo has been adjusted at the factory in accordance with the standard specification of the actuator, the servo gain need not be changed in normal conditions of use.

However, vibration or noise may occur depending on how the actuator is affixed, specific load condition, and so on, and therefore the parameters relating to servo adjustment are disclosed to allow the customer to take quick actions should adjustment become necessary.

Particularly with custom models (whose ball screw lead or stroke is longer than the that of the standard model), vibration/noise may occur due to external conditions.

In this case, the parameters shown below must be changed. Contact IAI for details.

- Servo Gain Number (No. 7 PLGO)

Parameter number	Unit	Input range	Default
7	5 rad/sec	0 ~ 15	6

This parameter determines the level of response with respect to a position control loop.

Increasing the setting improves compliance with the position command.

However, increasing the setting too much increases the tendency of the actuator to overshoot.

If the setting is low, compliance with the position command drops and the positioning time increases as a result.

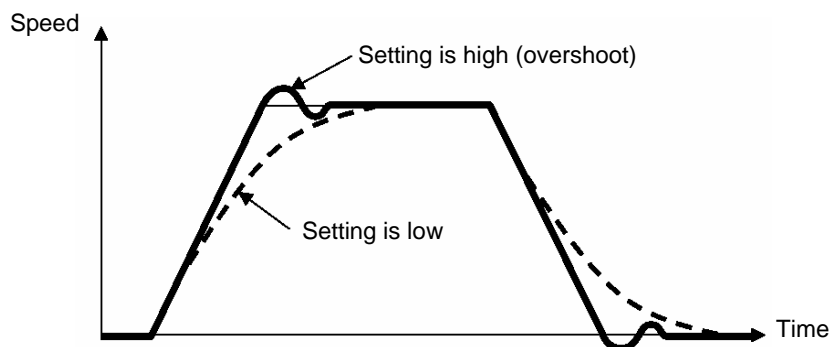

- Speed Loop Proportional Gain (No. 31 VLPG)

Parameter number	Unit	Input range	Default
31	---	1 ~ 27661	Set individually in accordance with the actuator characteristics.

This parameter determines the level of response with respect to a speed control loop.

Increasing the setting improves compliance with the speed command (i.e., servo rigidity increases).

The greater the load inertia, the higher the setting should be.

However, increasing the setting too much increases the tendency of the actuator to overshoot or oscillate, resulting in increased mechanical vibration.

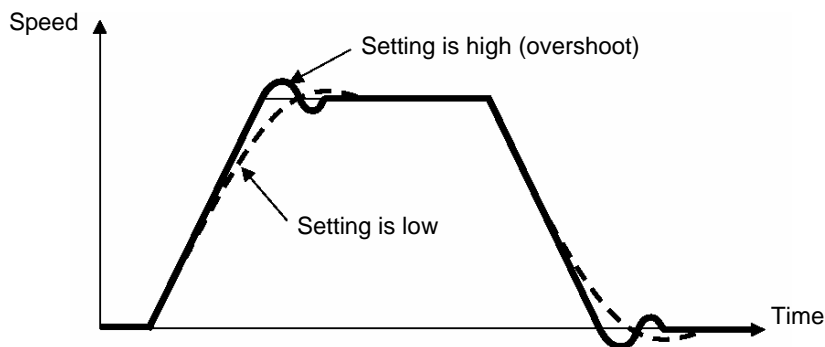

- Speed Loop Integral Gain (No. 32 VLPT)

Parameter number	Unit	Input range	Default
32	---	1 ~ 217270	Set individually in accordance with the actuator characteristics.

This parameter determines the level of response with respect to a speed control loop. Increasing the setting results in lower response with the speed command and decreases the reactive force upon load change. Decreasing the setting too much increases the tendency of the actuator to overshoot or oscillate, resulting in increased mechanical vibration. If the setting is low, compliance with the position command drops and the positioning time increases as a result.

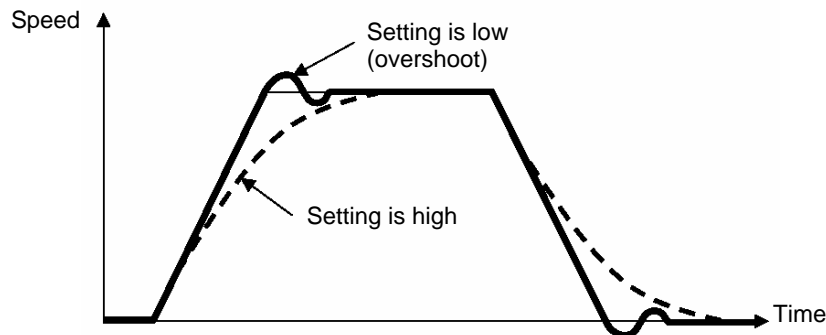

- Torque Filter Time Constant (No. 33 TRQF)

Parameter number	Unit	Input range	Default
33	---	1 ~ 2500	Set individually in accordance with the actuator characteristics.

This parameter determines the filter time constant applicable to the torque command. If the mechanical resonance frequency is equal to or lower than the servo loop response frequency, the motor will vibrate. This mechanical resonance can be suppressed by increasing the setting of this parameter. It should be noted, however, that increasing the setting too much may affect the stability of the control system.

- Current Control Band Number (No. 54 CLPF)

Parameter number	Unit	Input range	Default
54	---	0 ~ 4	Set individually in accordance with the actuator characteristics.

This parameter is used to change the current control band. A value corresponding to the applicable actuator is set at the factory. Never change this parameter. If the parameter is changed, stability of the control system may be affected and a very dangerous situation may occur.

- Feed-forward Gain (No. 71 PLFG)

Parameter number	Unit	Input range	Default
71	---	0 ~ 100	Set individually in accordance with the actuator characteristics.

Set the amount of feed-forward gain of the position control system.

Setting this parameter increases the servo gain and improves the response of operation that uses a position control loop.

Use this parameter to improve the response of a mechanical system whose rigidity is low or load inertia ratio is high.

As a rough guide, set a value between "10" and "80." Increasing the value set in this parameter reduces the deviation and improves the response.

Take note, however, that setting an excessively large value may generate vibration or noise.

## 6. Troubleshooting

### 6.1 What to Do When A Problem Occurs

If you encountered a problem, follow the steps below to conduct the specified checks to gather information needed to implement quick recovery and prevent recurrence of the problem.

- a. Check the status indicator lamps  
 SV (green) --- The servo is on.  
 ALM (red) --- An alarm is present or emergency stop has been actuated, or the motor drive power is cut off.
- b. Check the host controller for abnormality.
- c. Check the voltage of the 24-VDC main power supply.
- d. Check the voltage of the 24-VDC power supply for I/O signals.
- e. Check for alarms.  
 Check the details of each alarm on the PC or teaching pendant.
- f. Check the cables for miswiring, disconnection and pinching.  
 Before checking the continuity of cables, turn off the power (to prevent a runaway actuator) and disconnect all wirings (to prevent the power from being supplied unexpectedly due to a sneak path).
- g. Check the I/O signals.
- h. Check the noise elimination measure (ground connection, surge killer installation, etc.).
- i. Identify how the problem occurred and the operating condition when the problem occurred.
- j. Check the serial numbers of the controller and actuator.
- k. Analyze the cause.
- l. Take an action.

Before contacting IAI, please check the items in a through j above. Provide the information to our technical staff.

(Reference) Changes in indicators and \*ALM output signal in each status

	Servo off	Servo on	Emergency stop actuated	Motor drive power cut off
SV (lamp)	Unlit	Lit	Unlit	Unlit
ALM (lamp)	Unlit	Unlit	Lit	Lit
*ALM (signal)	OFF	OFF	ON	ON

(Note 2) The \*ALM output signal is a contact-b signal.

After the power is input, these signals remain ON while the controller is normal. They turn OFF when the power is cut off.

These signals cannot be used for providing a contact-b interlock when the power is not supplied to the controller.

## 6.2 Alarm Level Classification

The alarms are classified into three levels based on the corresponding symptoms.

Alarm level	ALM lamp	*ALM signal	Condition at occurrence of alarm	How to reset
Operation cancellation	Lit	Output	The actuator decelerates to a stop, and then the servo turns off.	Execute reset using the PC/teaching pendant.
Cold start	Lit	Output	The actuator decelerates to a stop, and then the servo turns off.	Reconnect the power.

Note: Whatever the alarm, always investigate the cause of the alarm and remove the cause before resetting the alarm. If the cause of the alarm cannot be removed, or when the alarm cannot be reset even after the cause has been removed, please contact IAI.  
If the same error occurs again after a reset, the cause of the alarm still exists.

## 6.3 Alarms, Causes and Actions

### (1) Operation Cancellation Alarms

Code	Error	Cause/action
0A1	Parameter data error	<p>Cause: The parameter data does not meet the specified input range. (Example) This alarm generates when a pair of values clearly has an inappropriate magnitude relationship, such as when the soft limit + setting is 200.3 mm, while the soft limit – setting is 300</p> <p>Action: Change the settings to appropriate values.</p>
0A4	Command counter overflow	<p>Cause: This alarm generates when the value in the command pulse counter deviates from the range of –134217728 to 134217728.</p> <p>Action: Check the setting of command pulses.</p>
0BA	Home sensor not yet detected	<p>This alarm indicates that the actuator equipped with a home sensor reached the mechanical end before a home sensor detection signal was output. (This alarm also generates when the actuator cannot move because the load is too heavy.)</p> <p>Cause: [1] The home sensor is not installed in an appropriate position and thus cannot be detected. [2] Open cable or inappropriately installed connector [3] The work is receiving an external force.</p> <p>Action: [1] Readjust the sensor installation position. [2] Perform electrical continuity check to see if the cable is open. Also check if the connector is installed properly. [3] Check the mechanisms around the work and make sure the work does not receive any strong external force. If the cause cannot be identified, contact IAI.</p>
0BE	Homing timeout	<p>Cause: After the start of homing, homing does not complete after elapse of the time set by the manufacturer's parameter. (This alarm does not generate during normal operation.)</p> <p>Action: As one possible cause, the controller and actuator combination may be incorrect. Contact IAI.</p>
0C0	Excessive actual speed	<p>Cause: The motor speed exceeds the maximum speed set by the manufacturer's parameter. This alarm does not generate during normal operation, but it may occur if the load decreased before a servo error was detected and the motor speed has increased as a result. This condition occurs due to the following reasons: [1] The slide resistance of the actuator is large in some areas. [2] The load increased due to momentary application of external force.</p> <p>Action: Check the assembly condition of mechanical parts for any abnormality. If the actuator itself is suspected as the cause, contact IAI.</p>
0C8	Overcurrent	<p>Cause: The output current of the power-supply circuit became abnormally high. This alarm should not generate in normal conditions of use. If it generates, the insulation of motor coil may have deteriorated.</p> <p>Action: Measure the inter-phase resistances among motor connection wires U, V and W, as well as the insulation resistance between the motor connection wires and ground, to check for deterioration of insulation.</p>

Code	Error	Cause/action
0C9	Overvoltage	<p>Cause: The regenerative energy produced could not be fully absorbed during deceleration and consequently the voltage of the power-supply circuit became abnormally high. Particularly when the actuator is installed vertically, this alarm often generates as the actuator decelerates to a stop following a move command in the downward direction.</p> <p>Action: Decrease the specified speed and acceleration/deceleration. If the error cannot be reset, contact IAI.</p>
0CA	Overheat	<p>Cause: [1] The temperature around the power transistor in the controller is excessively high (95°C or above). [2] When the actuator is installed vertically, regenerative resistance energy is insufficient during downward movement because of a high deceleration setting. [3] Defective part in the controller</p> <p>Action: [1] Lower the temperature around the controller. [2] Revise the specified conditions to make the deceleration curve more gradual. If neither [1] nor [2] applies, contact IAI.</p>
0CB	Current-sensor offset adjustment error	<p>The status of the current detection sensor in the controller is checked during the initialization process. This alarm indicates that the sensor was found abnormal as a result of this check.</p> <p>Cause: [1] Faulty current detection sensor or peripheral component</p> <p>Action: The board must be replaced. Contact IAI.</p>
0CC	Abnormal control power-supply voltage	<p>The voltage of the 24-V input power supply is excessive (24 V + 20%: 28.8 V or above).</p> <p>Cause: [1] The voltage of the 24-V input power supply is high. [2] Faulty part in the controller</p> <p>Action: Check the input power-supply voltage. If the voltage is normal, contact IAI.</p>
0CD	Blown emergency-stop relay	<p>Cause: The emergency-stop relay in the controller blew.</p> <p>Action: The relay or controller must be replaced. Contact IAI.</p>
0D8	Deviation overflow	<p>The position deviation counter has overflowed.</p> <p>Cause: [1] The work hit a surrounding object during movement and the impact caused the speed to drop. [2] The specified acceleration is too high for the transferred mass. [3] The brake is improperly engaged and cannot be released correctly.</p> <p>Action: [1] Check the mechanisms around the work and make sure the work does not receive any strong external force. If [3] is suspected as the cause, contact IAI.</p>
0D9	Software limit over	This alarm indicates that a soft limit was reached.

## (2) Cold Start Alarms

Code	Error	Cause/action
0B7	Indeterminable magnetic pole	<p>When the controller is started, the magnetic pole is detected during the first two seconds. This alarm generates if the magnetic pole could not be detected successfully during this period.</p> <p>Cause: [1] The connector of the motor relay cable is loose or its circuit is open.            [2] If the actuator is equipped with a brake, the brake has not been released.            [3] The motor load increased due to application of external force.            [4] The slide resistance of the actuator itself is high.</p> <p>Action: [1] Check the wiring condition of the motor relay cable.            [2] Check the wiring condition of the brake cable, and also turn on/off the brake release switch to check if "click" sound is heard.            [3] Check the assembly condition of mechanical parts for any abnormality.            [4] If the load is normal, cut off the power and move the actuator by hand to check the slide resistance.</p> <p>If the actuator itself is suspected as the cause, contact IAI.</p>
0E0	Overload	<p>Cause: [1] The load increased due to application of external force.            [2] If the actuator is equipped with a brake, the brake cannot be released.            [3] The slide resistance of the actuator is large in some areas.</p> <p>Action: [1] Check the work and its surroundings. If the work is receiving any abnormal external force, make the necessary corrections to remove the force.            [2] Turn on the brake release switch to see if the brake is released. If the brake is not released, the brake itself may be faulty, or an open cable or faulty brake circuit component in the controller is suspected, among others.            [3] If the work can be moved by hand, do so to check for any area where the slide resistance increases.</p> <p>If [2] or [3] is the case, contact IAI.</p> <p>Note: Be sure to remove the cause of the alarm before resuming the operation. If the power has been cut off, wait for at least 30 minutes before reconnecting the power to prevent the motor coil from being burned.</p>
0E8	Open phase A/B	<p>Encoder signals cannot be detected correctly.</p> <p>Cause: [1] The connector of the encoder relay cable is loose or its circuit is open.            [2] The connector of the actuator relay cable is loose or its circuit is open.</p> <p>Action: Check the connection condition of the encoder relay cable and perform continuity check. If no abnormality is found, contact IAI.</p>
0FA	CPU error	<p>The CPU is not operating correctly.</p> <p>Cause: [1] Malfunction due to the effect of noise, etc.            [2] The CPU itself is faulty.            [3] Faulty circuit component around the CPU</p> <p>Action: Reconnect the power.            If the problem still persists after the power has been reconnected, check for effect of noise.            If a spare controller is available, replace the problem controller with the spare controller. If the problem still persists after the controller has been replaced, noise is suspected as the cause.            If the cause cannot be identified, contact IAI.</p>

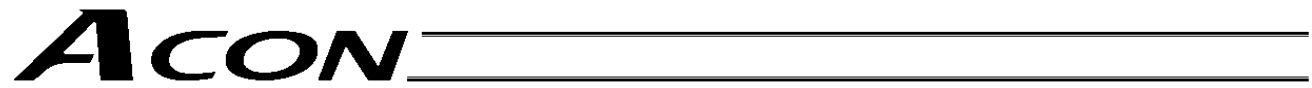

(3) Non-alarm Message

Code	Error	Cause/action
FFF	Power on log	This is not an error. (It simply means that a rise of controller power has been detected.)

## 6.4 Messages Displayed during Teaching Pendant Operation

This section explains the warning messages that may be displayed while operating the teaching pendant or PC software.

Code	Message	Description
112	Input data error	An inappropriate value was input as a user parameter setting. (Example) "9601" was input as the serial communication speed by mistake. Input an appropriate value again.
113 114	Input value too small Input value too large	The input value is under the setting range. The input value is over the setting range. Input an appropriate value again by referring to the actuator specifications and parameter list.
115	Homing not yet complete	The current position was written before homing was complete. Perform homing first.
116	Last position data available	Data was stored in the last position fields when an attempt was made to add data to the position table. Clear or delete the data for the last position.
117	No movement data	No target position is set under the selected position number. Input a target position first.
11E	Inconsistent data pair	The magnitude relationship of a pair of data is inappropriate. (Example) The same value is set in both the + and – soft limit parameters. Input appropriate values again.
11F	Absolute value too small	The minimum travel toward a target position is determined by the lead of the drive system and encoder resolution. This message indicates that the input target position is less than this minimum travel. (Example) If the lead is 20 mm, the encoder resolution is 800 pulses and therefore the minimum travel is calculated as 0.025 mm/pulse (20 ÷ 800). If 0.02 mm is input as the target position, this message will be displayed.
121	Push search end over	The final position in push-motion operation exceeds a soft limit. No harm is done as long as the actuator contacts the work. If it misses the work, however, the actuator will reach the soft limit and this message will be displayed. Change either the target position or positioning band.
122	Multiple axes connected at assignment	An axis number was assigned when multiple axes were connected. Always assign an axis number when only one axis is connected.
180 181 182	Axis number change OK Controller initialization OK Home change all clear	This is an operation check message. (It does not indicate misoperation or error.)
201	Emergency stop	An emergency stop status was detected. (This is not an error.)
20A	Servo OFF during movement	The servo ON signal (SON) was turned OFF by the PLC while the actuator was moving. As a result, the servo turned OFF and the actuator stopped.

Code	Message	Description
20C	CSTR-ON during movement	The start signal (CSTR) was turned ON from the PLC while the actuator was moving, resulting in redundant move commands.
20d	STOP-OFF during movement	The pause signal (*STP) was turned OFF from the PLC while the actuator was moving, disabling the actuator movement.
20E	Soft limit over	A soft limit was reached.
20F	Missed work detected	The actuator passed the work without contacting it in push-motion operation. Review the work condition as well as the target position/positioning band settings.
210	HOME-ON during movement	The homing signal (HOME) was turned ON from the PLC while the actuator was moving, resulting in redundant move commands.
211	JOG-ON during movement	The jog signal (JOG) was turned ON from the PLC while the actuator was moving, resulting in redundant move commands.
301 302 304 305 306 308 30A 30B	Overrun error (M) Framing error (M) SCIR-QUE OV (M) SCIS-QUE OV (M) R-BF OV Response timeout (M) Packet R-QUE OV Packet S-QUE OV	An error occurred in serial communication with the controller. Cause: [1] Garbage data due to noise [2] Duplicate slave numbers when multiple actuators are controlled via serial communication Action: [1] Revise the wiring, equipment layout, etc., to eliminate noise. [2] Change the slave numbers to eliminate duplication. If the message persists, please contact IAI.
307 309	Memory command denied Write address error	A command was denied in serial communication with the controller. An indeterminable write address error occurred in serial communication with the controller. These messages do not generate during normal operation. Should either of them occur, record the entire error list before turning off the power. The recorded error list will help us identify the cause of the problem. Also contact IAI.
30C	No connected axis	The controller axis number cannot be recognized. Cause: [1] The controller is not operating properly. [2] Only the communication line of the supplied cable (SGA/SGB) is open. [3] If the SIO converter is used, the link cable is not connected although the converter is receiving 24 V. [4] When multiple controllers are linked, the ADRS switch is set to the same number by mistake on two or more controllers. Action: [1] Check if the RDY LED on the controller is lit. If this LED is not lit, the controller is faulty. [2] If you have a spare teaching pendant, change to the spare teaching pendant. Or, switch to the PC software mode and see if the message will disappear. [3] Connect all pairs of converter and controller using link cables, and then supply the power. [4] Set each ADRS switch to a unique number. If the message persists, please contact IAI.

## 6.5 Common Problems and Recommended Actions

- I/O Signals Cannot Be Sent or Received to/from the PLC.  
Cause: [1] The 24-V I/O power supply is connected in reverse polarities.  
(In this case, input circuits are not affected, but output circuits will be damaged.)  
[2] If an output circuit presents this problem, electrical current exceeding the maximum current flowed due to a large load and a circuit component was damaged.  
[3] Poor contact at the connector or relay terminal block on the PLC side.  
[4] The female pins on the flat cable connector are bent outward, thus causing contact failure with the male pins on the controller connector.  
Action: Check the connection condition of the power supply and connector, as well as the load on the output side. If [1] or [2] is suspected, the controller must be replaced. If [4] is likely, the flat cable must be replaced. Either way, contact IAI.

 Caution: When checking the continuity of the shield cable, exercise due caution not to bend the female pins on the connector outward. It may cause contact failure, resulting in malfunction.
---

- The ALM Lamp Illuminates after the Power Is Turned On.  
(An alarm is present, emergency stop is actuated, or the motor power is cut off.)
  - \* If the ALM output signal is OFF, an alarm is present. Connect a PC or teaching pendant to check the nature of the error and remove the cause.
  - \* If the ALM output signal is ON, the emergency stop circuit is actuated.Check the following items:
  - [1] Is the emergency stop switch on the operation panel pressed by mistake? Is the necessary interlock canceled?
  - [2] Is the emergency stop switch on the teaching pendant pressed by mistake?
  - [3] If multiple controllers are linked together, are they wired correctly?
- After Turning On the Power, the SV Lamp Does Not Illuminate upon Servo-on Signal Input.  
(The Servo Does Not Turn On.)  
Cause: [1] Inappropriate contact of the shield cable  
[2] Faulty controller  
Check the servo-on signal (SON) in the I/O monitor screen on the PC or teaching pendant.  
If the signal is input, the controller may be faulty. Contact IAI.

- The Actuator does not Operate when a Pulse Train is Input.  
Cause: [1] The I/O I/F signal issued with the pulse train is invalid.  
[2] The command-pulse train pattern is not set properly in the parameters.  
Action: [1] Check the input signal.  
[2] Check User Parameter No. 63 (Command-pulse input mode) and No. 64 (Polarity in command-pulse input mode).

 Caution: With certain third-party host controllers, the positive and negative logic settings of pulse train patterns are opposite to those of IAI's controllers. Reverse the positive and negative logic settings to see if the problem is resolved.

- With an Actuator Installed in Vertical Orientation, Noise Generates during Downward Movement.  
Cause: The load exceeds the rated load capacity.  
Action: [1] Decrease the speed.  
[2] Decrease the value set in User Parameter No. 7 (Servo gain number). As a guide, do not decrease the setting to below 3.
- Stopped Position Sometime Deviates from the Home Position or Target Position.  
Cause: [1] Encoder waveforms are disturbed due to noise.  
[2] If the actuator is of rod type, non-rotational error increased due to application of rotational moment to the  
Action: [1] Check if the grounding is provided correctly, and also check for any equipment that may be generating  
[2] Depending on the condition, the actuator may have to be replaced. Contact IAI.
- The Actuator Moves Only a Half, or as Much as Twice, the Specified Travel.  
Cause: [1] The controller and actuator combination is incorrect.  
[2] The ball screw lead varies according to the actuator type. If the actuator is not combined with an appropriate controller, the travel and speed will change.  
[3] Wrong electronic gear setting  
[4] Pre-shipment setting error at IAI  
Action: [1] If multiple actuators of different types are used, check the label on each actuator or use other means to see if they are connected to correct controllers.  
[2] Recalculate for electronic gear.  
[3] Contact IAI.
- The Actuator Installed in the Vertical Orientation Completes Homing before the Home Is Reached.  
Cause: [1] The ball screw is receiving torsional stress due to the affixing method of the actuator, unevenly tightened bolts, etc.  
[2] The slide resistance of the actuator itself is high.  
Action: [1] Loosen the affixing bolts to check if the slider moves smoothly.  
[2] If the slide resistance of the actuator itself is high, contact IAI.

- The Actuator Malfunctions when the Servo Is Turned On after Turning On the Power.

Cause: Excited phase detection is not performed properly when the servo is turned on, because one of the following conditions exists when the power was turned on:

- [1] The slider or rod was contacting a mechanical end.
- [2] The work was pushed by a strong external force.

Action: [1] Check if the slider or rod is not contacting a mechanical end. If the slider/rod is contacting a mechanical end, separate the slider/rod from the mechanical end.

If the actuator is equipped with a brake, turn on the brake release switch to forcibly release the brake before moving the actuator. At this time, be careful not to pinch your hand or damage the robot hand or work by the slider/rod, as the slider/rod may drop unexpectedly by its dead weight.

If the actuator cannot be moved by hand, one measure is to check the direction of excited phase signal detection and change the direction of detection as necessary. If you wish to change the direction, contact IAI beforehand.

For details, refer to the applicable parameter explained in 6.2.2, "Parameters Relating to Actuator Operating Characteristics."

[2] Check if the work is not contacting any peripheral equipment.

If the work is contacting peripheral equipment, separate the work from the equipment by providing a minimum clearance of 1 mm in between.

If neither [1] nor [2] applies, contact IAI.

## \* Appendix

### Specification List of Supported Actuators

#### ● Slider Type

Model	Stroke (mm), maximum speed (mm/sec) *1																Maximum loading capacity		Rated acceleration		
																	Horizontal	Vertical	Horizontal	Vertical	
	50	100	150	200	250	300	350	400	450	500	550	600	700	800	900	1000	1100	1200	(kg)	(kg)	(G)
RCA-SA4C-I-20-10-***	665																4	1	0.3	0.3	
RCA-SA4C-I-20-5-***	330																6	2.5	0.3	0.3	
RCA-SA4C-I-20-2.5-***	165																8	4.5	0.2	0.2	
RCA-SA5C-□-20-12-***	800																4	1	0.3	0.3	
RCA-SA5C-□-20-6-***	400																8	2	0.3	0.3	
RCA-SA5C-□-20-3-***	200																12	4	0.2	0.2	
RCA-SA6C-□-30-12-***	800																6	1.5	0.3	0.3	
RCA-SA6C-□-30-6-***	400																12	3	0.3	0.3	
RCA-SA6C-□-30-3-***	200																18	6	0.2	0.2	

#### ● Rod Type

Model	Stroke (mm), maximum speed (mm/sec) *1										Rated thrust	Maximum push force	Maximum loading capacity		Rated acceleration		
													Horizontal	Vertical	Horizontal	Vertical	
	50	100	150	200	250	300	350	400	450	500	550	600	(N)	(N)	(kg)	(kg)	(G)
RCA-RA3C-I-20-10-***	500										36.2	—	4	1.5	0.3	0.3	
RCA-RA3C-I-20-5-***	250										72.4	—	9	3	0.3	0.3	
RCA-RA3C-I-20-2.5-***	125										144.8	—	18	6.5	0.2	0.2	
RCA-RA4C-□-20-12-***	600										18.9	—	3	1	0.3	0.3	
RCA-RA4C-□-20-6-***	300										37.7	—	6	2	0.3	0.3	
RCA-RA4C-□-20-3-***	150										75.4	—	12	4	0.2	0.2	
RCA-RA4C-□-30-12-***	600										28.3	—	4	1.5	0.3	0.3	
RCA-RA4C-□-30-6-***	300										56.6	—	9	3	0.3	0.3	
RCA-RA4C-□-30-3-***	150										113.1	—	18	6.5	0.2	0.2	

#### ● Arm Type

Model	Stroke (mm), maximum speed (mm/sec) *1												Thrust	Maximum loading capacity		Rated acceleration	
														Horizontal	Vertical	Horizontal	Vertical
	50	100	150	200	250	300	350	400	450	500	550	600	(N)	(kg)	(kg)	(G)	(G)
RCA-A4R-□-20-10-***	300												39.2	—	2.5	—	0.2
RCA-A4R-□-20-5-***	165												78.4	—	4.5	—	0.2
RCA-A6R-□-20-12-***	400												33.3	—	2	—	0.2
RCA-A6R-□-20-6-***	200												65.7	—	4	—	0.2
RCA-A6R-□-30-12-***	400												48.4	—	3	—	0.2
RCA-A6R-□-30-6-***	200												96.8	—	6	—	0.2

#### ● Dustproof/Splash-proof Type

Model	Stroke (mm), maximum speed (mm/sec) *1																Maximum push force	Maximum loading capacity		Rated acceleration	
																		Horizontal	Vertical	Horizontal	Vertical
	50	100	150	200	250	300	350	400	450	500	550	600	650	700	750	800	(N)	(kg)	(kg)	(G)	(G)
RCA-RA3C-I-20-10-***	500																—	4	1.5	0.3	0.3
RCA-RA3C-I-20-5-***	250																—	9	3	0.3	0.3
RCA-RA3C-I-20-2.5-***	125																—	8	6.5	0.2	0.2

\*1 The elongated circle represents applicable strokes, and the value in the elongated circle indicates the maximum speed corresponding to each applicable stroke.

## Parameter Record

Recorded date: \_\_\_\_\_

- Types: a: Parameter relating to actuator stroke range  
 b: Parameter relating to actuator operating characteristics  
 c: Parameter relating to external interface  
 d: Servo gain adjustment

No.	Type	Symbol	Name	Unit	Recorded data
3	a	LIMM	Soft limit + side	mm	
4	a	LIML	Soft limit – side	mm	
5	a	ORG	Home direction [0: Reverse / 1: Forward]	-	
7	d	PLGO	Servo gain number	-	
9	b	ACMD	Default acceleration/deceleration	G	
10	b	INP	Default positioning band (in-position)	mm	
13	b	ODPW	Current-limiting value during homing	%	
16	c	BRSL	SIO communication speed	bps	
17	c	RTIM	Minimum delay time for slave transmitter activation	msec	
18	c	LS	Home sensor input polarity [0: None / 1: Contact a / 2: Contact b]	-	
21	c	SON	Servo-on input [0: Enable / 1: Disable]		
22	a	OFST	Home offset	mm	
25	c	IOPN	PIO pattern selection	-	
28	b	PHSP	Default direction of excited phase signal detection [0: Reverse / 1: Forward]		
29	b	PHSP	Excited phase signal detection time	msec	
30	b	PHSP	Pole sensing type [0: Current suppression / 1: Distance suppression]	-	
31	d	VLPG	Speed loop proportional gain	-	
32	d	VLPT	Speed loop integral gain	-	
33	d	TRQF	Torque filter time constant	-	
35	b	SAFV	Safety speed	mm/sec	
40	c	HOME	Homing input [0: Enable / 1: Disable]	-	
42	b	ENBL	Enable function [0: Enable / 1: Disable]	-	
43	b	HMC	Home check sensor input polarity [1: Contact a / 2: Contact b]	-	
45	c	SIVM	Silent interval multiplication factor	-	
52	c	HSTP	Default acceleration/deceleration mode	-	
54	d	CLPF	Current control band number	-	
55	b	PLPF	Primary filter time constant for position command	msec	
57	b	TQLM	Torque limit	%	
58	c	SDCR	Clear deviation at servo off/alarm stop [0: Disable / 1: Enable]	-	
59	b	FSTP	Monitor error while limiting torque [0: Disable / 1: Enable]	-	
60	c	DCLR	Deviation-counter clear input [0: Enable / 1: Disable]	-	

No.	Type	Symbol	Name	Unit	Recorded data
61	c	TL	Torque-limit command input [0: Enable / 1: Disable]	-	
62	b	CPR	Pulse count direction [0: Forward / 1: Reverse]	-	
63	c	MOD	Command-pulse input mode	-	
64	c	POLE	Polarity in command-pulse input mode [0: Positive / 1: Negative]	-	
65	b	CNUM	Electronic gear numerator	-	
66	b	CDEN	Electronic gear denominator	-	
71	d	PLFG	Position feed-forward gain	-	
77	b	LEAD	Ball screw lead [mm]	mm	



---

---

MEMO

---

---





## ***IAI America, Inc.***

Head Office: 2690 W. 237th Street, Torrance, CA 90505

TEL (310) 891-6015 FAX (310) 891-0815

Chicago Office: 1261 Hamilton Parkway, Itasca, IL 60143

TEL (630) 467-9900 FAX (630) 467-9912

Atlanta Office: 1220 E. Kennestone Circle, Marietta, GA 30066

TEL (678) 354-9470 FAX (678) 354-9471

Website: [www.intelligentactuator.com](http://www.intelligentactuator.com)

## ***IAI Industrieroboter GmbH***

Ober der Röth 4, D-65824 Schwalbach am Taunus, Germany

TEL 06196-88950 FAX 06196-889524