

P-Driver

PULSE DRIVE

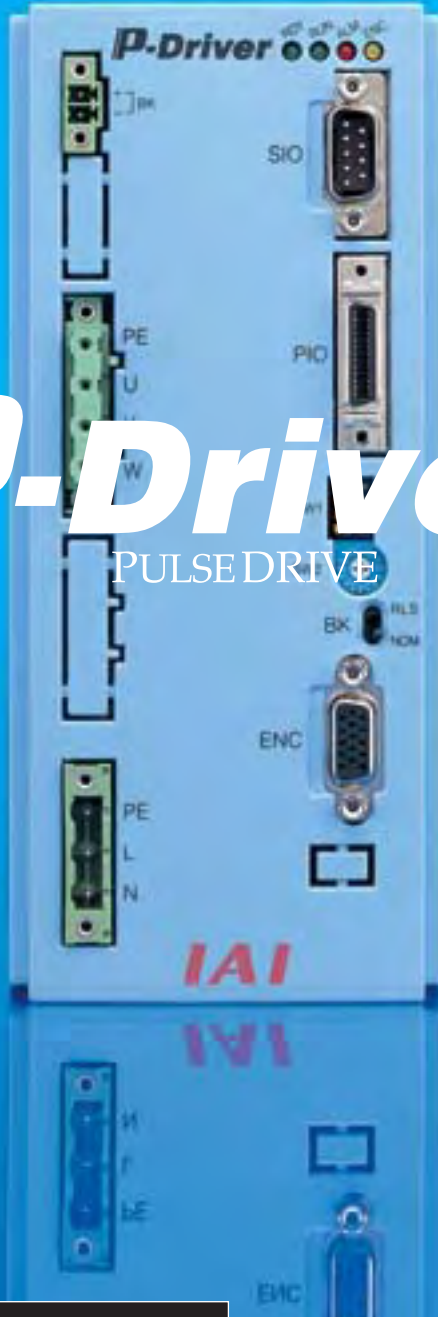

AGENT

IAI America, Inc.





Pulse-Train Input Driver for Positioning

P-Driver

P-Driver is a pulse-train input driver that enables flexible operation of IAI's ROBO CYLINDER and single-axis robots. (Note 1)



(Note 1) Certain types of ROBO CYLINDER cannot be operated by P-Driver. See the table below for the compatible actuator types.

Controller		P-Driver 	E-Con 	RCS-C 	RCP-C 
Positioning command		Pulse train (Sequence control)	PIO (Position number)		
Number of positioning points		No limitation	64 points	16 points	16 points
Input power supply		100VAC 200VAC	100VAC 200VAC	100VAC 200VAC 24VDC	24VDC
Compatible actuators	RCP				○
	RCS- SA4/SA5/SA6				○
	RCS- RA35/RA45				○
	RCS- RB7525				○
	RCS- SS/SM	○	○	○	
	RCS- SSR/SMR	○	○	○	
	RCS- RA55/F55	○	○	○	
	RCS- RB7530 RB7535	○		○	
	DS (T1 specification)	○			
	SS IS/ISP ISD ISD-CR ISPD-CR IF FS (All T1 specification)	○	○		
	12RS (T1 type)	○			
	RCS-R10I RCS-R20I RCS-R30I RCS-G20I	○	○		

Flexible Control of IAI's ROBO CYLINDER and Single-Axis Robots Using Pulse Train

- The P-Driver can control a wide range of ROBO CYLINDERS and single-axis robots in desired manners. (Motor wattage: 20W to 750W, Strokes: 50mm to 3,000mm)
- The P-Driver comes fully assembled and pre-formatted to the specific actuator ordered. Cost, assembly time and design time can be reduced as compared to integrating a system in-house by assembling the ballscrew, motor, linear guides and various other parts.
- Pulse-train control puts no limitation on the number of positioning points.

Dedicated Homing Signal

The dedicated homing input enables automatic homing without programming a complex sequence.

Torque Limiting Function

Torque can be limited using external signal (via parameter setting). Signal is output when the specified torque is reached. Push operation and press-fitting become possible with the use of this function.

Brake Control Function

- The actuator's brake (optional) is controlled via a dedicated circuit inside the controller. There is no need to program a special sequence.
- With the use of a dedicated power supply (24 VDC), the brake can be forcibly released while the driver's main power is off.

Feedback Function

- Position detection data can be output in pulse trains (differential output). This enables reading of the current position in real time from the host controller.

Feed-Forward Control Function

- Response can be improved under certain conditions when the load inertia ratio is high. Increasing the parameter setting decreases the deviation, thus resulting in improved response. (Deviation is the difference between the position command and the position feedback.)

Position-Command Primary Filter Function

- Soft start and stop are possible even with command pulse inputs for which acceleration/deceleration is not specified.

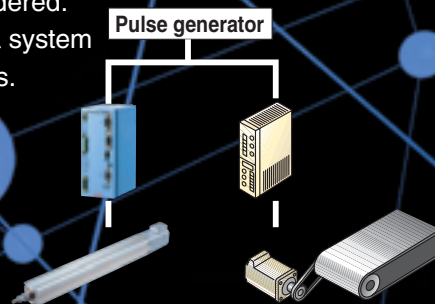

Model

PDR-I-100 B-1-P

- ① Series PDR: P-Driver
- ② Encoder type I: Incremental
- ③ Motor capacity 20: 20W / 30: 30W / 60: 60W / 100: 100W / 150: 150W / 200: 200W / 400: 400W / 600: 600W / 750: 750W
- ④ Options (Blank): None / B: Brake / C: Creep sensor / L: Limit switch
- ⑤ Power-supply voltage 1: 100V / 2: 200V
- ⑥ I/O method (Blank): NPN specification / P: PNP specification

System Configuration

Compatible Actuators:

- Ballscrew Drive Type DS/SS/IS/ISP/ISD
- Belt Drive Type IF/FS
- Clean Room Type ISD-CR/ISPD-CR
- ROBO CYLINDER Slider Type RCS-SS/SSR/SM/SMR
- ROBO CYLINDER Rod Type RCS-RA55/RB7530/RB7535
- ROBO CYLINDER Flat Type RCS-F55
- ROBO Rotary RCS-R10I/20I/30I
- ROBO Gripper RCS-G20I

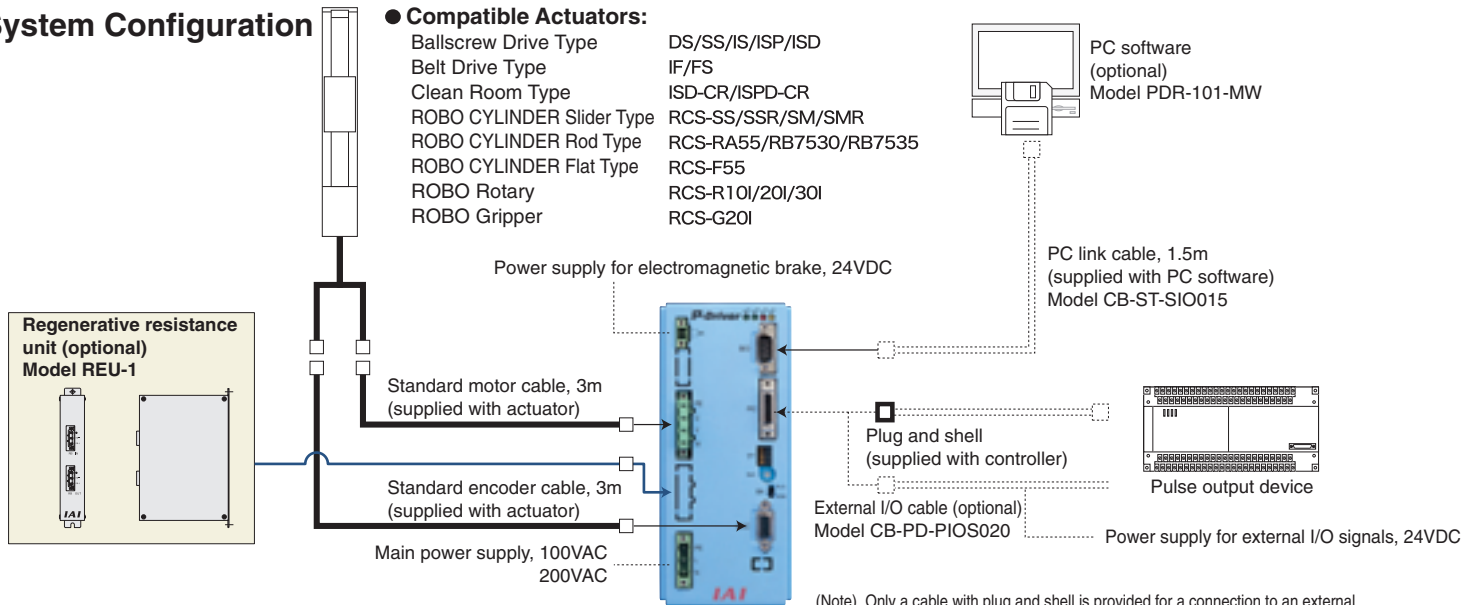

(Note) Only a cable with plug and shell is provided for a connection to an external device. Solder the cable or use an optional external I/O cable.

Options

PC software Model PDR-101-MW

Content: Floppy disks, PC link cable 1.5m (Unit model CB-ST-SIO015)

Used to set P-Driver parameters, monitor jogging operation during debugging, check various signals, and so on.

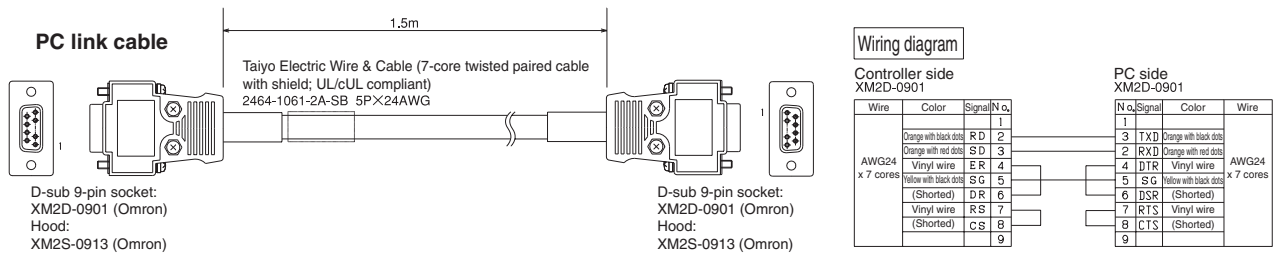

External I/O cable Model CB-PD-PIOS020

Content: Plug, shell and 2-m shielded cable (no connector at end)
Use this cable for connection with a pulse output device.

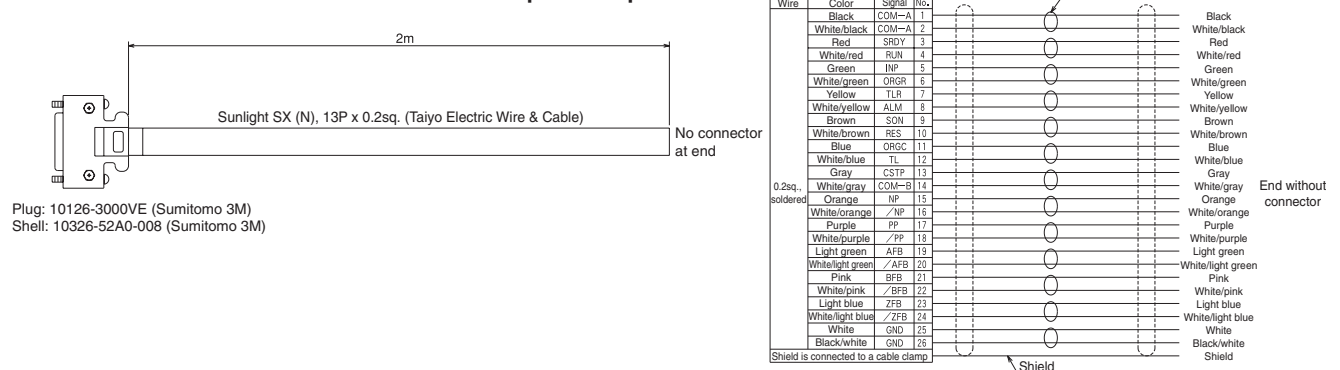

Name of Each Part

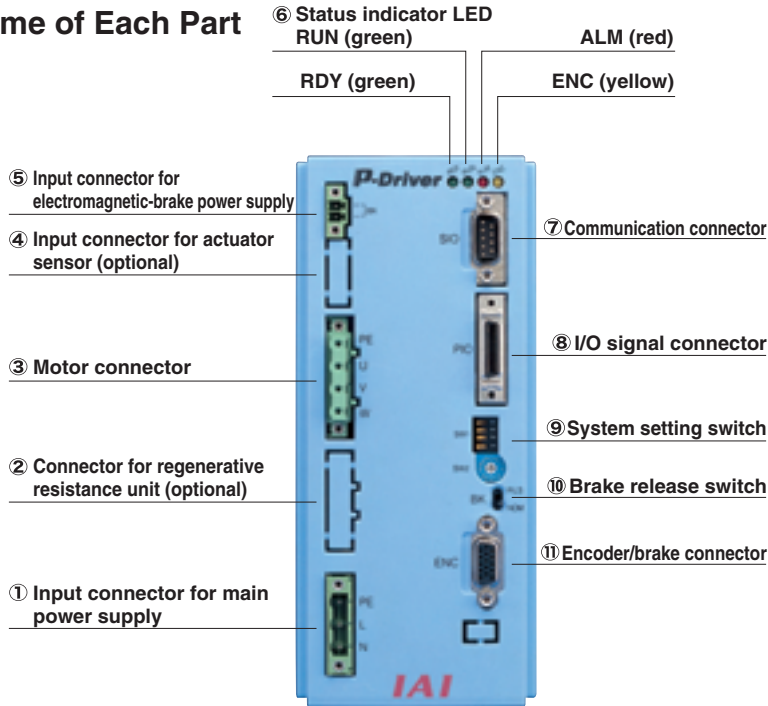

- ① Input connector for main power supply ... Connects the power supply.
- ② Connector for regenerative resistance unit ... Connects a regenerative resistance unit (optional).
- ③ Motor connector ... Connects the actuator's motor cable.
- ④ Input connector for actuator sensor ... Connects cables from the actuator's sensors such as LS, CREEP and OT (optional).
- ⑤ Input connector for electromagnetic-brake power supply ... Connects the power supply for electromagnetic brake.
(An electromagnetic brake requires an external power supply.)
- ⑥ Status indicator (LED) ... Used to monitor the controller's operating condition.
- ⑦ Communication connector ... Connects the PC software cable.
- ⑧ I/O signal connector ... Connects the control I/O signals.
- ⑨ System setting switch ... This switch is used to change the encoder voltage and for remote start operation. (The rotary switch is used for adjustment by the manufacturer.)
- ⑩ Brake release switch ... This switch is used to forcibly release the brake.
- ⑪ Encoder/brake connector ... Connects the actuator's encoder/brake cable.

Specification Table

Actuator motor capacity (W)	20	30	60	100	150	200	400	600	750	
Power capacity	(W)	34	42	100	150	210	270	520	770	1000
	(VA)	57	70	160	240	350	450	870	1300	1600
Input power supply	100V specification: single-phase, 100 to 115VAC ±10%, 50/60Hz									
	200V specification: single-phase, 200 to 230VAC ±10%, 50/60Hz									
Control method	Sine wave PWM, vector current control									
Position detection method	Incremental encoder									
Braking method	Regenerative resistance									
Function/performance	Control mode	Position control via pulse-train input								
	Maximum input pulse frequency	Max. 500kpps (differential) / Max. 200kpps (open-collector)								
	Command pulse magnification (electronic gear: A/B)	A, B = 1 to 4096 1/50 < A/B < 50/1 (parameter setting)								
	Positioning completion width	1 to 4096 pulses (parameter setting)								
Power supply for I/O signal I/F	24VDC ±20%, 0.8A (supplied externally)									
Power supply for electromagnetic brake	24VDC ±20%, 1A (peak value) (supplied externally)									
Communication function	RS232C (for dedicated PC software)									
Protection functions	Motor overvoltage, overcurrent, abnormal driver temperature, encoder error, motor overload, etc.									
Environmental conditions	Operating temperature/humidity	0 to 40°C, 85%RH or less (non-condensing)								
	Storage temperature	-20 to 70°C (non-condensing)								
	Operating ambience	Free from corrosive or flammable gases, oil mist or dust.								
	Durability/vibration	4.9m/s ²								
Insulation resistance	1500VAC for 1 minute (1000VAC for 1 minute with actuator connected)									
Protection structure	Open, forced air cooling (IP20)									
Weight	1.2kg									

Regenerative Resistance Unit

Model REU-1

Features • This unit converts the regenerative current that generates when the motor decelerates into heat. A regenerative resistor is installed in the controller, but its capacity may not be sufficient if a large load is supported on a vertical axis. In this case, a separate regenerative resistance unit is required.

Specifications

Item	Specification
Unit dimensions	W34mm×H195mm×D126mm
Unit weight	0.9kg
Ratings of built-in regenerative resistance	220Ω 80W
Accessory	Controller link cable (Model CB-ST-REU010), 1m

Installation Standards

Motor wattage	Horizontal application
20~150W	Not required.
200~600W	
750W	

*The above table shows reference values when the driver is used in the rated conditions (load capacity, speed and acceleration).

Dimensions

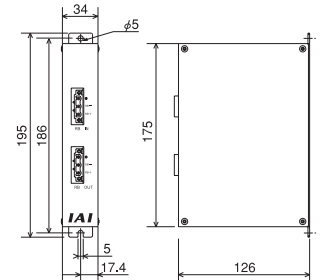

Interface Circuit

Sequence input part

Item	Description
Number of input signal points	5 points
Input voltage	24VDC \pm 20%
Input current	7mA/point
Operating voltage	ON voltage ... Min. 16V (4.5mA) OFF voltage ... Max. 6V (1.4mA)
Insulation method	Photo-coupler

NPN specification

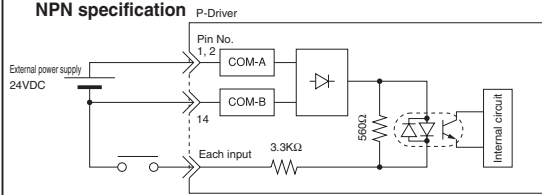

PNP specification

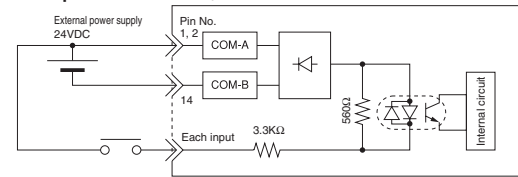

Sequence output part

Item	Description
Number of output signal points	6 points
Rated load voltage	24/60VDC (peak; without flywheel diode)
Maximum load current	100mA/point
Residual voltage	1.8V/100mA
Insulation method	Photo-coupler
Overcurrent protection	Fuse resistance: 10Ω, 0.1W

NPN specification

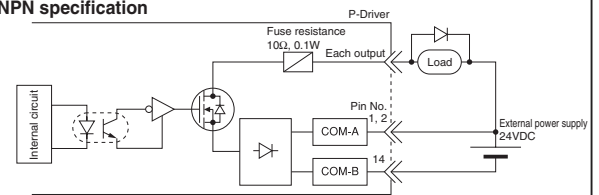

PNP specification

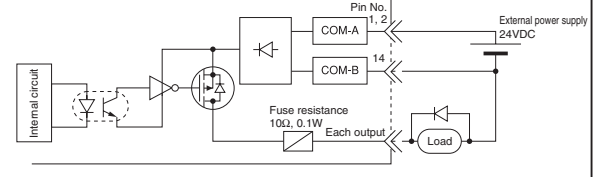

Command Pulse-Train Input Part

Differential line-driver input

Applicable line driver: 26C31 or equivalent

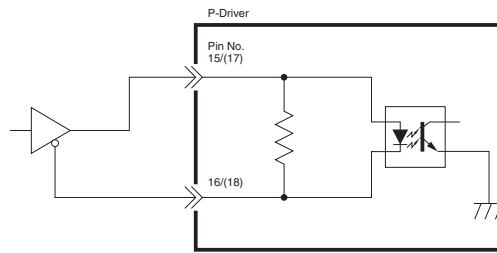

Open-collector input

Pull-up resistance: 2.2kΩ

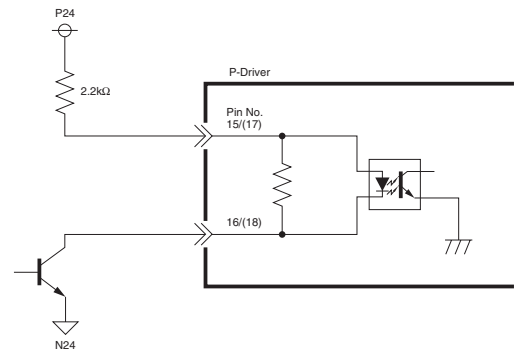

Feedback pulse output

Applicable line receiver: 26C32 or equivalent

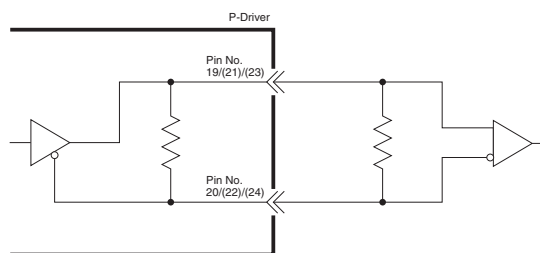

Standard Connection Diagram

A connection diagram of P-Driver proper is provided.

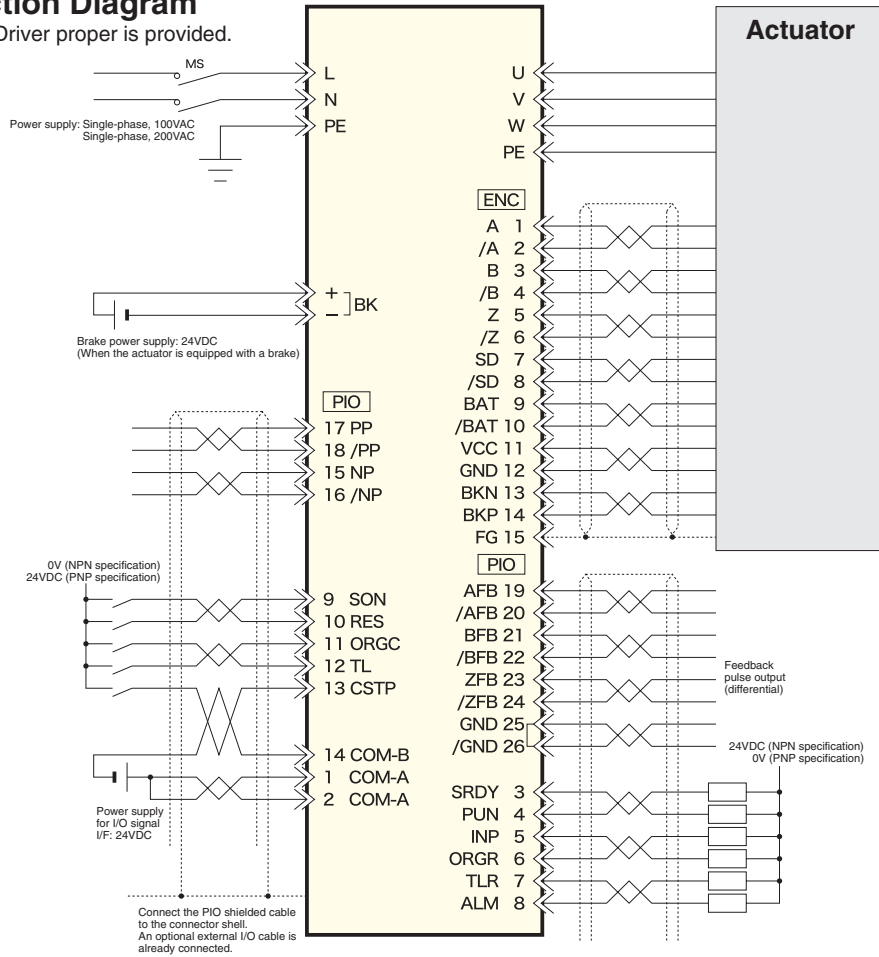

External I/O Signals

Pin No.	I/O category	Code	Signal name	Function
1	Power supply for I/O	COM-A	Power-supply common (+)	Power-supply common for external I/O signals, 24VDC, connected to the + side (Pins 1 and 2 are connected internally.)
2		COM-A		
3	Sequence signal output	SRDY	System ready	Turns ON when control is enabled following a power input. Synchronized with ON/OFF of the corresponding LED located on the front side of the enclosure.
4		RUN	Operation ready	Turns ON when the servo is turned ON (operation is enabled). Synchronized with ON/OFF of the corresponding LED located on the front side of the enclosure.
5		INP	Positioning completion	Turns ON when the robot enters the in-position range set by parameter.
6		ORGR	Homing completion	Turns ON when homing is complete.
7		TLR	Torque limiting	Turns ON when the actuator output reaches the parameter-set torque limit while TL is ON.
8	Sequence signal input	ALM	Alarm	Turns OFF when a protection circuit (function) is actuated and the base current is interrupted (this signal is normally ON).
9		SON	Servo ON	Motor is turned on when input is on. Required for movement.
10		RES	Alarm reset	Alarm is reset when this signal turns ON.
11		ORGC	Homing command	Homing starts when this signal turns ON.
12		TL	Torque limit selection	Limiting of actuator torque starts when this signal turns ON. (Torque limiting is cancelled when the signal turns OFF.)
13	Power supply for I/O	CSTP	Forced stop	When this signal turns ON, the robot decelerates to a stop at the forced stopping torque and the servo is turned OFF.
14		COM-B	Power-supply common (-)	Power-supply common for external I/O signals, 24VDC, connected to the - side
15	Command pulse input	NP	Pulse-train input	Command pulse-train input:
16		/NP		Open-collector method (Max. 200kpps)
17		PP		Differential receiver method (Max. 500kpps)
18		/PP		Command pulse mode is specified (from 6 modes) using parameter.
19	Feedback pulse differential output	AFB	+A	Position detection data is converted to pulses and output (phases A, B and Z). Pulse output mode is specified (from 6 modes) using parameter.
20		/AFB	-A	
21		BFB	+B	
22		/BFB	-B	
23		ZFB	+Z	
24		/ZFB	-Z	
25	Reference potential	GND	Reference potential	For feedback pulse output
26		GND		Line driver ground line (Pins 25 and 26 are connected internally.)

Command Pulse Input Modes

Command pulse-train mode		Input terminal	Forward	Reverse
Negative logic	Forward pulse train	PP· /PP		
	Reverse pulse train	NP· /NP		
	A forward pulse train indicates motor revolutions in the forward direction, while a reverse pulse train indicates motor revolutions in the reverse direction.			
	Pulse train	PP· /PP		
	Sign	NP· /NP	Low	High
	A command pulse indicates motor revolutions and its sign indicates the rotating direction of the motor.			
Positive logic	Forward pulse train	PP· /PP		
	Reverse pulse train	NP· /NP		
	Motor revolutions and rotating direction are specified by phases A/B (4 multiplications) with a 90-degree phase difference.			
	Pulse train	PP· /PP		
	Sign	NP· /NP	High	Low
	Phase A/B pulse train	PP· /PP		
		NP· /NP		

* Output modes of feedback pulse follow the same classification.

External Dimensions

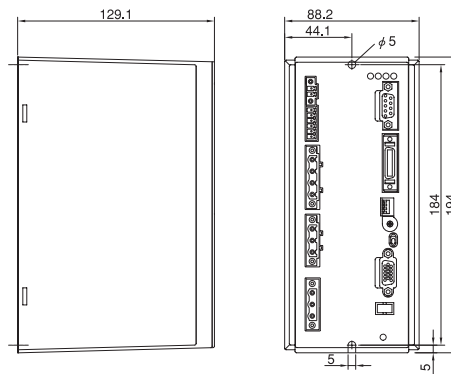

IAI America, Inc.

Head Office: 2690 W 237th Street, Torrance, CA 90505
 TEL: 1-800-736-1712
 Chicago Office: 1261 Hamilton Parkway, Itasca, IL 60143
 TEL: 1-800-944-0333
 New Jersey Office: 7 South Main Street, Suite-F, Marlboro, NJ 07746
 TEL: 732-683-9101

IAI Industrieroboter GmbH

Ober der Röth 4, D-65824 Schwalbach am Taunus, Germany

