

IAI

Quality and Innovation

ROBO Cylinder Position Controller SCON Series, 6-axis Type

MScON

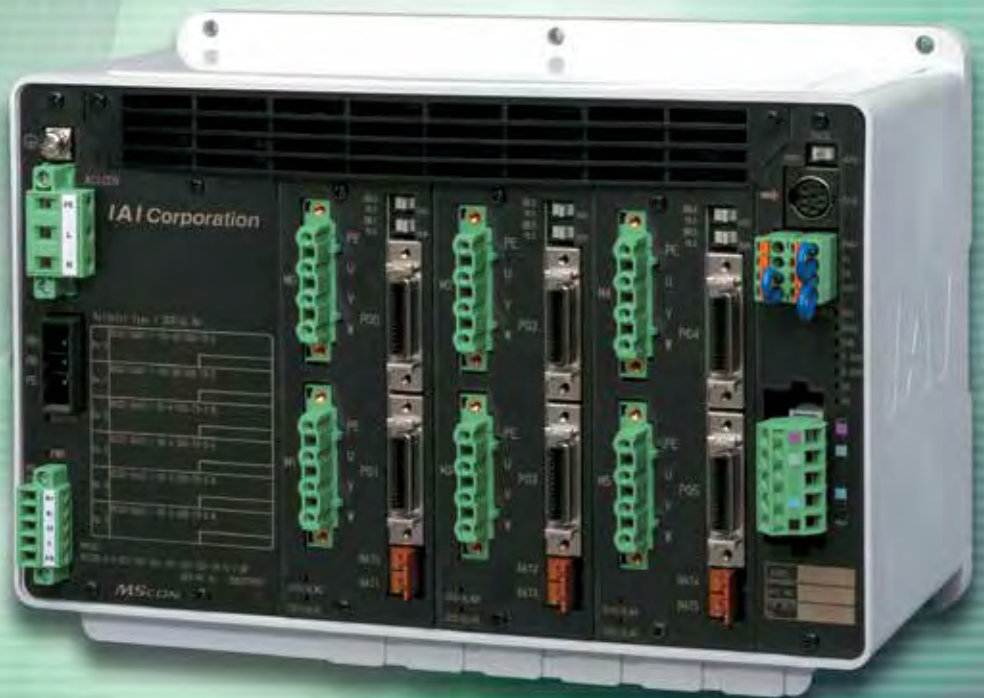

www.intelligentactuator.com

Combining six RCS2/RCS3 position controllers into one unit

Space-saving, low-cost dedicated network multi-axis controller



1 Space-saving, low-cost, and easy to use

Six RCS2/RCS3 (SCON-CA) controllers are combined into one unit to save the installation space and achieve significant reduction in total cost.



In implementations where many SCON controllers are used, switching to M5CON controllers will save the controller installation space to a half or even less. As the controller panel size becomes smaller, cost drops significantly.

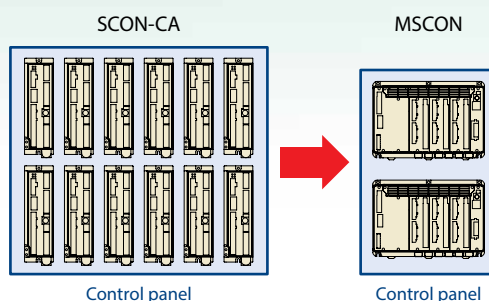

<Easy Teaching>

When teaching the moving position of each axis, the SCON controller requires that the teaching tool (cable) be disconnected from/connected to each controller one by one. With the M5CON controller, all you need is to switch the screen to change the data input axis, which saves the adjustment time.

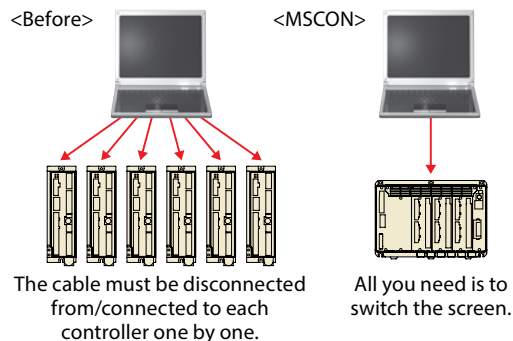

<Actuators Supported by M5CON>

	ROBO Cylinder <RCS2 series>	ROBO Cylinder <RCS3 series>	Single-axis robot <ISA/ISB series, NS series, RS series, etc.>
12W			
20W			
30W			
60W			
100W			
150W			
200W			

* Linear servo actuators are not supported.

2 Movement by numerical specification via Field network Substantially shorter transmission time

MSCON controllers can be connected directly to key field networks such as DeviceNet, CC-Link, PROFIBUS-DP, MECHATROLINK(*), CompoNet, EtherCAT(*) and EtherNet/IP.

Specifications supporting the networks indicated by (*) will be available soon.

Features of Network Specification

- 256 positioning points per axis
- Moving the actuator after numerically specifying the position to move to, and the speed
- Checking the current position in real time
- Significantly shorter communication time within the controller (approx. one-sixth compared to conventional controllers)



3 Offboard tuning function to enhance actuator payload capacity

The offboard tuning function increases the acceleration/deceleration speed when the load is small, and decreases the acceleration/deceleration when the load is large, to ensure optimal operation settings according to the load.

4 Vibration control function for shorter cycle time

The vibration control function has been added to prevent the work from shaking (vibrating) on the actuator slider as the slider moves. The wait time for vibration to stabilize is shorter and the cycle time can also be shortened.

5 Calculating the total number of moves and total distance travelled to alert when maintenance is due









The total number of times the actuator has moved, and total distance travelled, are calculated and recorded in the controller, and a signal will be output to an external device once the preset count or distance is exceeded. This function lets you know when to add grease or carry out periodic inspection.

6 Calendar function to save alarm generation times

The additional clock function makes it easy to analyze alarms as the alarm history is based on time of generation. (Time data will be retained for 10 days after the power is turned off.)

MSCON Controller

Model List/Standard Price

Model		MSCON-C							
External view									
I/O type		DeviceNet connection specification	CC-Link connection specification	PROFIBUS-DP connection specification	CompoNet connection specification	MECHATROLINK II connection specification (Note)	EtherCAT connection specification (Note)	EtherNet/IP connection specification	
									
I/O type model code		DV	CC	PR	CN	ML	EC	EP	
Standard price	Number of axes	Encoder	Standard price						
Standard price	1 axis	Incremental	—	—	—	—	—	—	—
		Absolute	—	—	—	—	—	—	—
	2 axis	Incremental	—	—	—	—	—	—	—
		Absolute	—	—	—	—	—	—	—
	3 axis	Incremental	—	—	—	—	—	—	—
		Absolute	—	—	—	—	—	—	—
	4 axis	Incremental	—	—	—	—	—	—	—
		Absolute	—	—	—	—	—	—	—
	5 axis	Incremental	—	—	—	—	—	—	—
		Absolute	—	—	—	—	—	—	—
	6 axis	Incremental	—	—	—	—	—	—	—
		Absolute	—	—	—	—	—	—	—

Available soon (Note)

Model Description

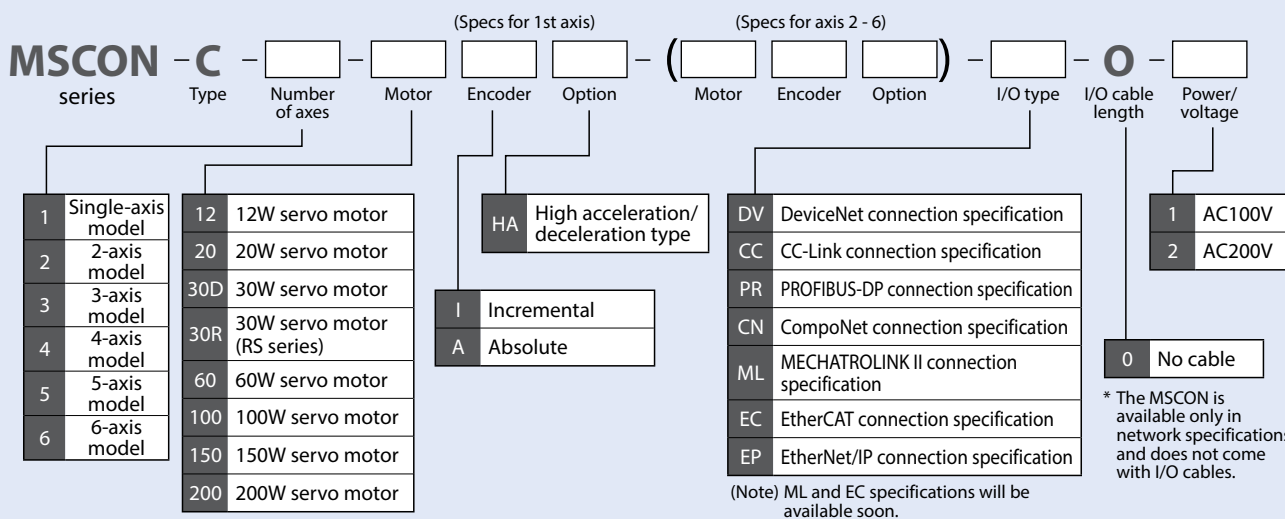

System Configuration

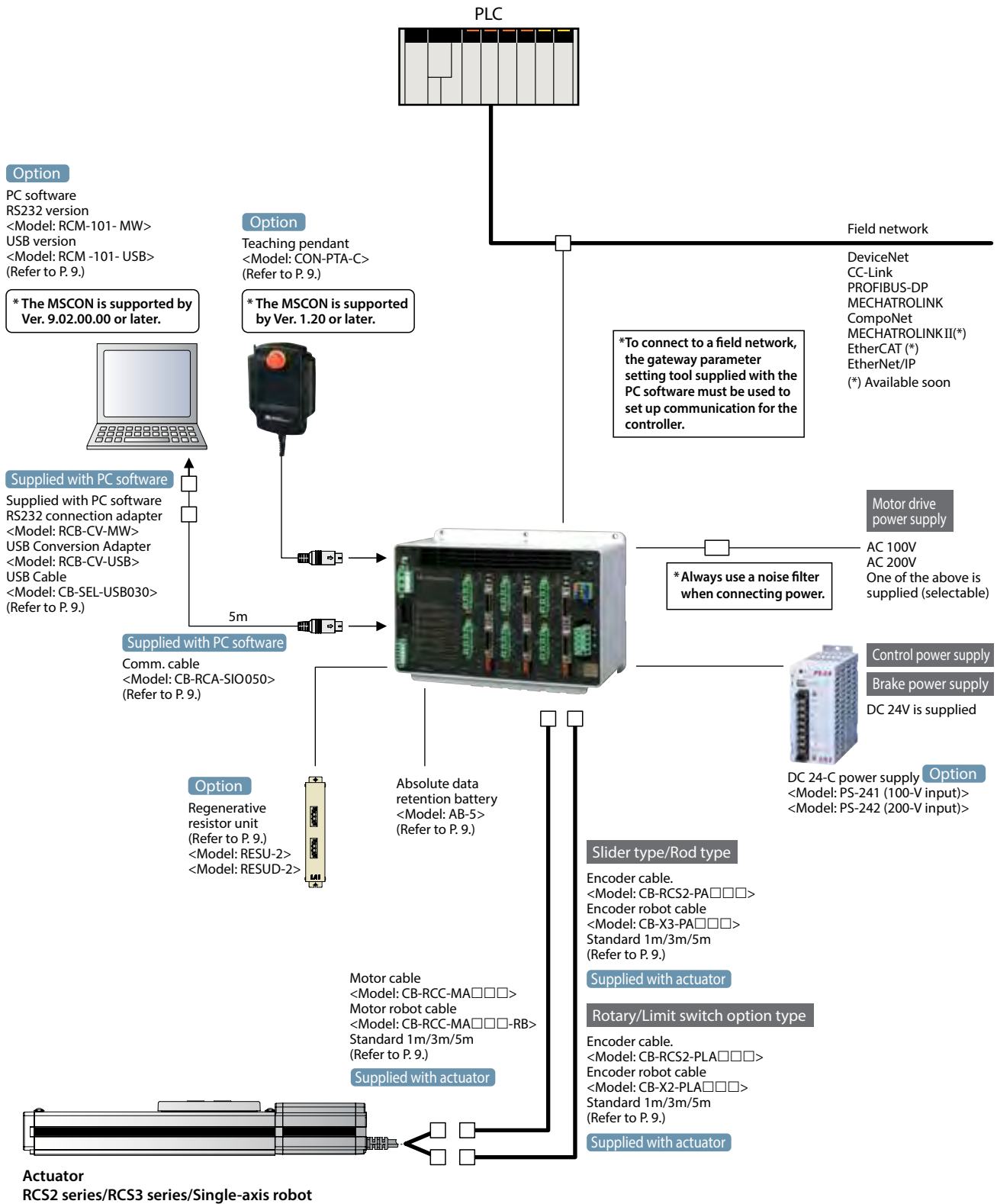

Note Take note that the following models are not supported by the MSCON:
All linear servo acuator models, RCS2-RN5N/RP5N/GS5N/GD5N/SD5N/TCA5N/TWA5N/TFA5N/SRA7BD/SRGS7BD/SRGD7BD,
NS-SXM□/SZM□ (both incremental specifications only)

MSCON Controller

Operation Mode

When the MSCON is controlled via a field network, one of the following seven operation modes can be used. The necessary data areas on the PLC side vary depending on the mode, so please consult the MSCON controller manual or contact IAI before use.

Mode	Description
Simple direct input mode	The target position is specified by directly entering a value, while other operating conditions (speed, acceleration, etc.) are set by specifying the desired position number corresponding to the desired operating conditions already input to the position data table.
Positioner 1 mode	The target position, speed, acceleration/deceleration, etc., are input to the position data table of the controller and input position numbers are specified to operate the actuator (maximum 256 points). The current position can be read, as well.
Direct input mode	The actuator is operated by specifying the target position, speed, acceleration/deceleration, push current control value, etc., by directly entering values. The current position, current speed, command current, etc., can also be read.
Direct input mode 2	Same as the direct input mode, except that jog operation is not supported and vibration control is added.
Positioner 2 mode	Same as the positioner 1 mode, except that the target position is not specified and reading of current position not supported, in order to reduce the amount of data to be transmitted/received.
Positioner 3 mode	Same as the positioner 2 mode, with the amount of data to be transmitted/received reduced further to allow for actuator operation with minimum input/output signals.
Remote I/O mode (*)	In this mode, the actuator is operated by controlling the ON/OFF of bits via the network, just like with the PIO specification. The number of positioning points and functions vary with each of the operation patterns (PIO patterns) that can be set by the controller's parameter.

(*) Take note that if the remote I/O mode is selected, all axes will operate in the remote I/O mode.

List of Functions for Operation Mode

	Simple direct input mode	Positioner 1 mode	Direct input mode	Direct input mode 2	Positioner 2 mode	Positioner 3 mode
Number of positions	Unlimited	256 points	Unlimited	Unlimited	256 points	256 points
Home return operation	○	○	○	○	○	○
Positioning operation	○	△	○	○	△	△
Speed & acceleration/deceleration setting	△	△	○	○	△	△
Pitch feed (inching)	△	△	○	○	△	△
Push-motion operation	△	△	○	○	△	△
Speed change during movement	△	△	○	○	△	△
Pause	○	○	○	○	○	○
Zone signal output	△	△	△	△	△	△
Vibration control	△	△	×	○	△	△
Reading of current value	○	○	○	○	×	×
Selection of PIO pattern	×	×	×	×	×	×

*○ indicates that direct setting is possible; △ indicates that position data or parameter must be input; and X indicates that the function is not supported.

	Remote I/O mode				
	Positioning mode	Teaching mode	256-point mode	Solenoid valve mode 1	Solenoid valve mode 2
Number of positions	64 points	64 points	256 points	7 points	3 points
Home return operation	○	○	○	○	×
Positioning operation	△	△	△	△	△
Speed & acceleration/deceleration setting	△	△	△	△	△
Pitch feed (inching)	△	△	△	△	×
Push-motion operation	△	△	△	△	×
Speed change during movement	△	△	△	△	×
Pause	○	○	○	○	×
Zone signal output	△	△	△	△	△
Vibration control	△	△	△	△	△
Reading of current value	×	×	×	×	×
Selection of PIO pattern	○	○	○	○	○

*○ indicates that direct setting is possible; △ indicates that position data or parameter must be input; and X indicates that the function is not supported.

Explanation of I/O Signal Functions

The table below explains the functions assigned to the controller's I/O signals.

The controller can be operated by setting the remote I/O mode, selecting one of modes 0 to 5, and then turning each port number ON/OFF via the network.

Classification		Setting of MSCON Parameter No. 25									
		Positioning mode		Teaching mode		256-point mode		Solenoid valve mode 1		Solenoid valve mode 2	
		0		1		2		4		5	
Port No.	Code	Signal name	Code	Signal name	Code	Signal name	Code	Signal name	Code	Signal name	
PLC output ↓ MSCON input	0	PC1	Command position number	PC1	Command position number	PC1	Command position number	ST0	Start position 0	ST0	Start position 0
	1	PC2		PC2		PC2		ST1	Start position 1	ST1	Start position 1
	2	PC4		PC4		PC4		ST2	Start position 2	ST2	Start position 2
	3	PC8		PC8		PC8		ST3	Start position 3	—	Cannot be used
	4	PC16		PC16		PC16		ST4	Start position 4	—	
	5	PC32		PC32		PC32		ST5	Start position 5	—	
	6	—	MODE	Teaching mode command	PC64	ST6	Start position 6	—			
	7	—	Cannot be used	JISL	Jog/inch switching	PC128	—	Cannot be used	—		
	8	—	—	JOG+	Jogging in + direction	—	Cannot be used	—	Cannot be used	—	
	9	BKRL	Forced brake release	JOG-	Jogging in - direction	BKRL	Forced brake release	BKRL	Forced brake release	BKRL	Forced brake release
	10	—	Cannot be used	—	Cannot be used	—	Cannot be used	—	Cannot be used	—	Cannot be used
	11	HOME	Home return	HOME	Home return	HOME	Home return	HOME	Home return	—	
	12	*STP	Pause	*STP	Pause	*STP	Pause	*STP	Pause	—	
	13	CSTR	Positioning start	CSTR/PWRT	Positioning start/position data load command	CSTR	Positioning start	—	Cannot be used	—	Cannot be used
	14	RES	Reset	RES	Reset	RES	Reset	RES	Reset	RES	
15	SON	Servo ON command	SON	Servo ON command	SON	Servo ON command	SON	Servo ON command	SON	Servo ON command	
MSCON output ↓ PLC input	0	PM1	Complete position number	PM1	Complete position number	PM1	Complete position number	PE0	Position complete 0	LS0	Rear end movement command 0
	1	PM2		PM2		PM2		PE1	Position complete 1	LS1	Rear end movement command 1
	2	PM4		PM4		PM4		PE2	Position complete 2	LS2	Rear end movement command 2
	3	PM8		PM8		PM8		PE3	Position complete 3	—	Cannot be used
	4	PM16		PM16		PM16		PE4	Position complete 4	—	
	5	PM32		PM32		PM32		PE5	Position complete 5	—	
	6	MOVE	Moving signal	MOVE	Moving signal	PM64	PE6	Position complete 6	—		
	7	ZONE1	Zone 1	MODES	Teaching mode signal	PM128	ZONE1	ZONE1	ZONE1	ZONE1	
	8	PZONE/ZONE2	Position zone/Zone 2	PZONE/ZONE1	Position zone/Zone 1	PZONE/ZONE1	Position zone	PZONE/ZONE2	Position zone/Zone 2	PZONE/ZONE2	Position zone/Zone 2
	9	—	Cannot be used	—	Cannot be used	—	Cannot be used	—	Cannot be used	—	Cannot be used
	10	HEND	Home return complete	HEND	Home return complete	HEND	Home return complete	HEND	Home return complete	HEND	Home return complete
	11	PEND	Positioning complete signal	PEND/WEND	Positioning complete signal/position data load complete	PEND	Positioning complete signal	PEND	Positioning complete signal	—	Cannot be used
	12	SV	Ready	SV	Ready	SV	Ready	SV	Ready	SV	Ready
	13	*EMGS	Emergency stop	*EMGS	Emergency stop	*EMGS	Emergency stop	*EMGS	Emergency stop	*EMGS	Emergency stop
	14	*ALM	Alarm	*ALM	Alarm	*ALM	Alarm	*ALM	Alarm	*ALM	Alarm
15	*BALM	Absolute battery voltage low warning	*BALM	Absolute battery voltage low warning	*BALM	Absolute battery voltage low warning	*BALM	Absolute battery voltage low warning	*BALM	Absolute battery voltage low warning	

In the table above, * accompanying each code indicates a negative logic signal.

MSCON Controller

List of Base Controller Specifications

Item	Specification
Number of controlled axes	1 to 6 axes
Control power-supply voltage	DC 24 V ± 10%
Control power-supply current consumption	2.4 A max.
Control power-supply rush current (Note 1)	7 A max., 5 msec or less
Drive (motor) power-supply voltage	Drive power-supply voltage AC 100 V specification
	Drive power-supply voltage AC 200 V specification
Drive (motor) power-supply rush current (Note 1)	Drive power-supply voltage AC 100 V specification
	Drive power-supply voltage AC 200 V specification
Connectable actuator motor capacity	Drive power-supply voltage AC 100 V specification
	Drive power-supply voltage AC 200 V specification
Electromagnetic brake power-supply voltage (when actuator with brake is connected)	DC 24 V ± 10%
Brake power-supply current	1 A max. per axis (0.5 A per axis in steady state)
Brake power-supply rush current (Note 1)	10 A max., 10 msec or less
Leak current (Note 2)	3.5 mA (motor power supply) ◎ No leak current from the control power supply or brake power supply
Motor control method	Sinusoidal PWM vector current control
Applicable encoder	Incremental serial encoder Absolute serial encoder
Serial communication (SIO port: Teaching only)	RS485: 1 channel (conforming to Modbus protocol) / Speed: 9.6 to 230.4 kbps
External interface	DeviceNet, CC-Link, PROFIBUS-DP, CompoNet, MECHATROLINKII (*), EtherNet/IP, EtherCAT (*) Specifications supporting the interfaces denoted by (*) will be available soon.
Data setting/input method	PC software, touch panel teaching, gateway parameter setting tool
Data retention memory	Saving of position data and parameters to nonvolatile memory (Memory can be rewritten an unlimited number of times)
Number of positioning points	Max. 256 points (Not limited in the simple direct input mode or direct input mode) Note: The number of positioning points varies depending on the operation mode selected by the parameter.
LED display (installed on the front panel)	Driver status LED x 2 Fieldbus status LED x 2 Gateway status LED x 5 Power-supply status LED x 2
Electromagnetic brake forced release switch (installed on the front panel)	Switched between NOM (standard) and RLS (forced releases)
Protective function	Overload, overcurrent, overvoltage, etc.
Electric shock protection mechanism	Class I
Isolation resistance	DC 500 V, 10 MΩ or more
Withstand voltage	AC 1500 V for 1 minute
External dimensions	225W×154H×115D
Weight	Incremental specification (When drivers for 6 axes are installed)
	Absolute specification (When drivers for 6 axes are installed)
Cooling method	Forced air cooling
Environment	Ambient operating temperature
	Ambient operating humidity
	Operating ambience
	Protection degree

Note 1: Take note that the rush current value varies depending on the impedance of the power supply line.

Note 2: Leak current varies depending on the motor capacity to be connected, cable length, and ambient environment. To protect against leak current, measure leak current at locations where the earth leakage breaker is set.

An earth leakage breaker must be selected that serves the specific purpose required, such as fire protection and injury protection.
Use an earth leakage breaker of harmonic wave type (inverter type).

Power Supply Selection

With the MSCON controller, motor driver power (AC 100 V/AC 200 V) and control power (DC 24 V) must be supplied separately. Check the necessary power-supply capacity according to the table below.

RS: Rotational shaft

Motor Drive Power-supply Capacity

Actuator motor W number	Motor power supply capacity [VA]	Momentary maximum motor power-supply capacity [VA]	Heat output [W]
12	41	123	1.7
20	50	150	2.0
30D (other than RS)	47	141	2.0
30R (RS)	138	414	4.0
60	146	438	4.8
100	238	714	7.0
150	328	984	8.3
200	421	1263	9.2

Selecting the Circuit Breaker

Select the circuit breaker as follows:

- Three times the rated current will flow through the controller during acceleration/deceleration. (Refer to "Momentary maximum motor power-supply capacity" above).
Select a circuit breaker that will not trip when this current flows. If the selected circuit breaker trips under this current, select another breaker of the next higher rated current. (Confirm on the operation characteristic curve in the manufacturer's catalog to confirm that the circuit breaker will not trip.)
- Select a circuit breaker that will not trip due to rush current. (Confirm on the operation characteristic curve in the manufacturer's catalog to confirm that the circuit breaker will not trip.)
- Select a rated break current that will break the circuit even when a short-circuit current flows.
Rated break current > Short-circuit current = Primary power-supply capacity of circuit breaker / Power-supply voltage

Consider allowance when selecting the rated current of circuit breaker.

<Rated current of circuit breaker>
Total sum of motor power-supply capacities of all actuators connected [VA] / AC input voltage x Safety factor (Rough guide: 1.2 to 1.3)

Control Power-supply (DC 24-V) Capacity

Calculate the DC 24-V power-supply capacity as follows:

- (1) Current consumption of control power supply: Select the applicable control power-supply current shown in the table below --- ①

Number of controlled axes (Note 1)	1 axis	2 axes	3 axes	4 axes	5 axes	6 axes
Heat generation from control power supply [W]	25.5	31.5	38.2	44.2	50.9	56.9
Control power-supply current [A]	1.1	1.3	1.6	1.8	2.1	2.4

(Note 1): Check the maximum number of controlled axes that can be connected to the MSCON. This information is available on the manufacturer's nameplate.
MSCON-C*-...: * represents the maximum number of axes that can be connected.

- (2) Current consumption of brake power supply: 1 A or 0.5 A (Note 2) x Number of actuators with brakes --- ②

(Note 2): When the brake is released, up to 1 A of current will flow per actuator for a period of approx. 100 ms.

If this maximum current can be accommodated by the DC 24-V power supply used which is capable of handling momentary load fluctuation at the time of peak load, etc., calculate at 0.5 A/unit. If not, calculate at 1 A/unit.

- (3) Rush current of control power supply: 7 A/ --- ③

[Selection of power supply]

Normally a power supply whose rated current is approx. 1.3 times is selected by considering approx. 30% of allowance on top of the load current of ① + ② above. Since the current of ③ will flow for a short period, select a power supply of the "peak load accommodation" specification or having enough allowance. If the selected power supply has no allowance, voltage may drop momentarily. In particular, pay attention to the power supply with remote sensing function.

External Dimensions

Incremental specification

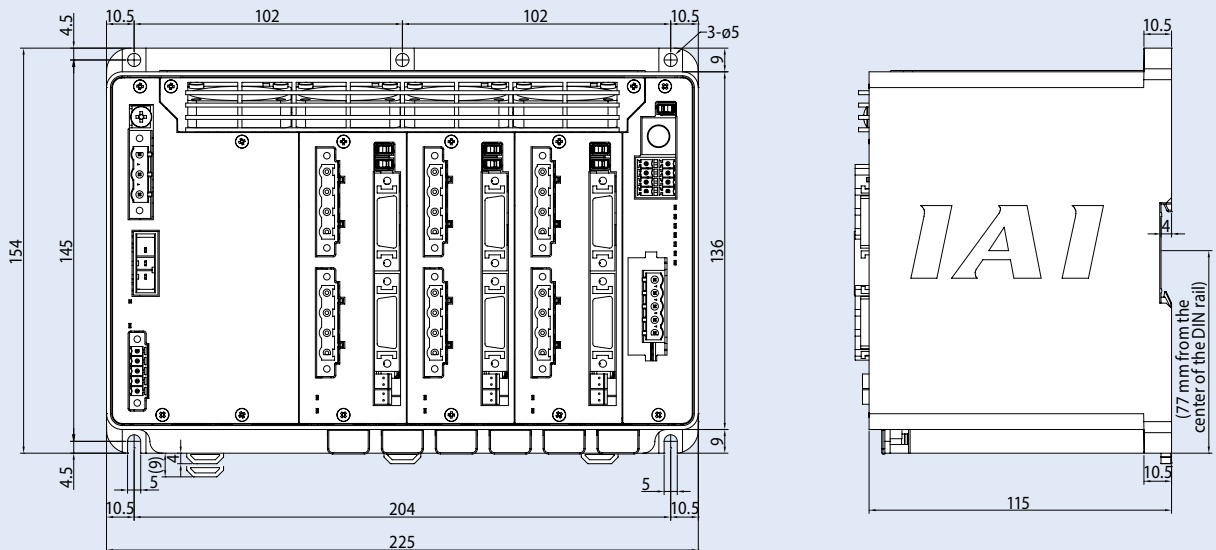

Absolute specification

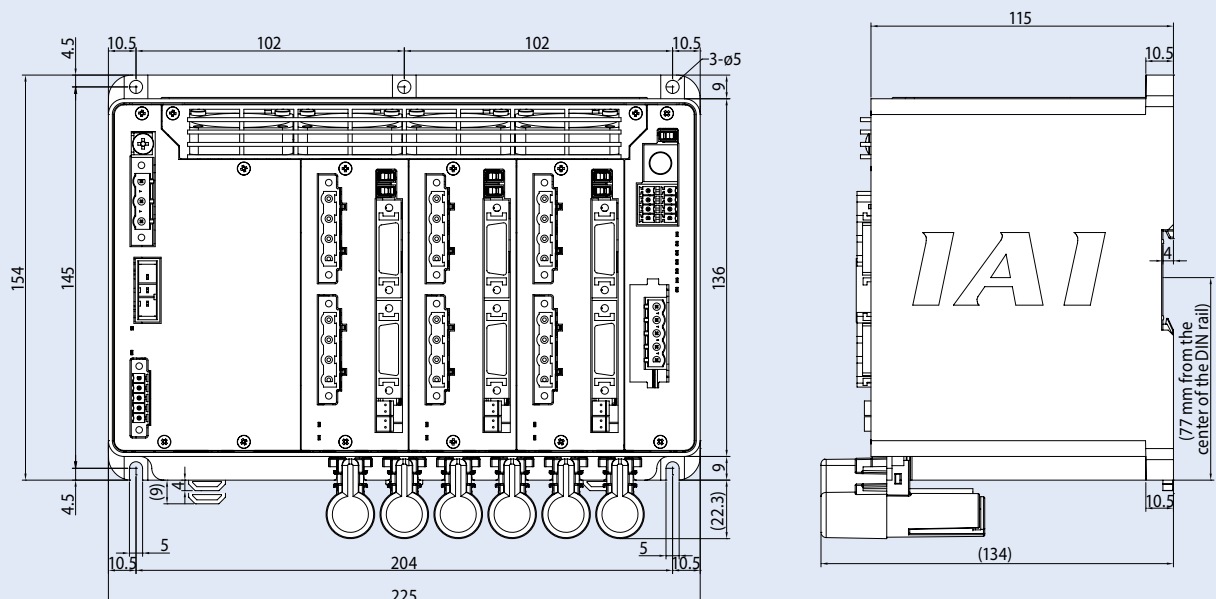

MSCON Controller

Option

Teaching Pendant

- Features Teaching device offering position input, test operation, monitoring and other functions.
- Model **CON-PTA-C** (Touch panel teaching)
- Configuration

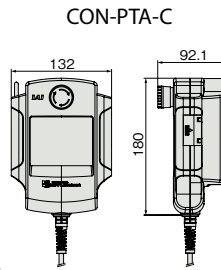
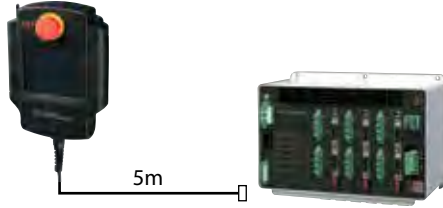

■ Specification

Item	CON-PTA-C
Data input	○
Actuator operation	○
Ambient operating temperature/humidity	Temperature 0 to 40°C Humidity 85%RH or less
Operating ambience	Free from corrosive gases or significant powder dust.
Protection degree	IP40
Weight	Approx. 570 g
Cable length	5m
Display	65,536 colors White LED backlight
Standard price	—

PC Software (Windows dedicated)

- Features This startup support software provides functions to input positions, perform test operations and monitor data, among others. Incorporating all functions needed to make adjustments, this software helps shorten the initial startup time.
- Model **RCM-101-MW** (With external device communication cable + RS232 conversion unit)
- Configuration The MSCON is supported by Ver. 9.02.00.00 or later.

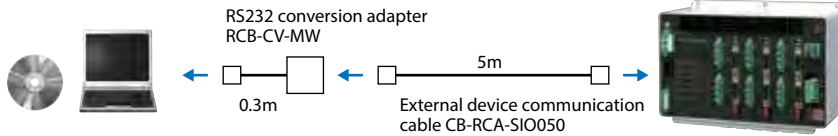

- Model **RCM-101-USB** (With external device communication cable + USB conversion adapter + USB cable)
- Configuration The MSCON is supported by Ver. 9.02.00.00 or later.

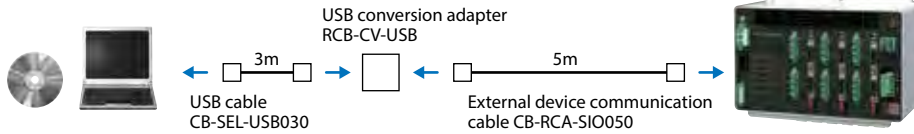

Regenerative Resistor Unit

- Features This unit converts regenerative current that generates when the motor decelerates, to heat. Check the total wattage of the actuators to be operated and provide a regenerative resistance unit or units if required.
- Model **RESU-2** (Standard specification)
RESUD-2 (DIN rail mount specification)
RESU-1 (Standard specification, second or subsequent unit)
RESUD-1 (DIN rail mount specification, second or subsequent unit)

* If two regenerative units are required, arrange one RESU-2/RESUD-2 (1st) and one RESU-1/RESUD-1 (2nd or after).

■ Specification

Model	RESU-2	RESUD-2	RESU-1	RESUD-1
Connected to	MSCON controller		RESU-1/RESUD-1	
Supplied cable	CB-SC-REU010		CB-ST-REU010	
Unit installation method	Screw mount	DIN rail mount	Screw mount	DIN rail mount
Main unit weight	Approx. 0.4g			
Built-in regenerative resistor	220 Ω, 80W			

* The first regenerative resistor unit connected to the MSCON should be the RESU-2/RESUD-2. The regenerative resistor unit connected to this regenerative resistor unit should be the RESU-1/RESUD-1.

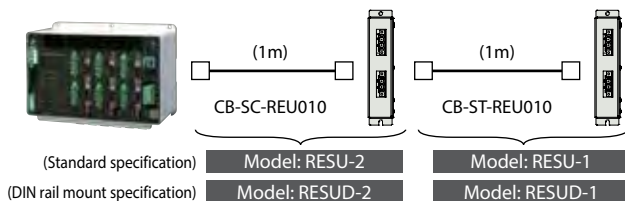

■ Reference Number of Units to Be Connected

Total wattage of 6 motor axes		Number of regenerative resistor units to be connected
Actuators installed horizontally	Actuators installed vertically	
~450	~200	0
~900	~600	1
—	~800	2
—	~900	3

Note:
The numbers of units to be connected are reference values based on the following operating conditions:
[Conditions] Operate the actuator to travel back and forth over 1000 mm at the maximum speed, acceleration/deceleration of 0.3 G, rated load, and operation duty of 50%.
Depending on the operating conditions, an error may generate and regenerative resistance greater than the applicable value shown in the table above may be required. In this case, add a regenerative resistor unit or units. Note that only up to four regenerative resistor units can be connected. If five or more units are connected, a failure may occur.

■ External dimensional drawing

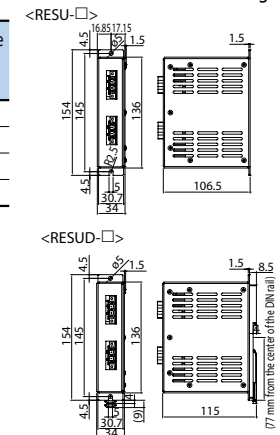

Maintenance Parts

Please refer to the models listed below if a cable needs to be exchanged, etc., after your purchase.

Motor cable/Motor robot cable

Model: **CB-RCC-MA** □□□ / **CB-RCC-MA** □□□ -**RB**

* Enter the cable length (L) into □□□. Compatible to a Maximum of 30 meters.
Ex.: 080 = 8m

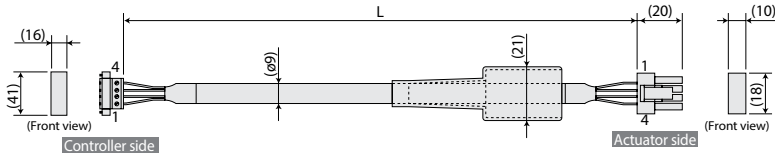

Wire	Color	Signal	No.	No.	Signal	Color	Wire
0.75sq	Green	PE	1	1	U	Red	0.75sq (crimped)
	Red	U	2	2	V	White	
	White	V	3	3	W	Black	
	Black	W	4	4	PE	Green	

Minimum bending R: r = 50 mm or more (when a robot cable is used)
* If the cable must be guided in a cable track, use a robot cable.

Encoder cable / Encoder robot cable

Model: **CB-RCS2-PA** □□□ / **CB-X3-PA** □□□

* Enter the cable length (L) into □□□. Compatible to a Maximum of 30 meters.
Ex.: 080 = 8m

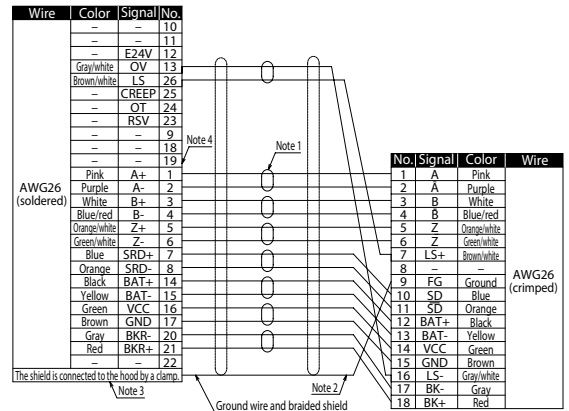
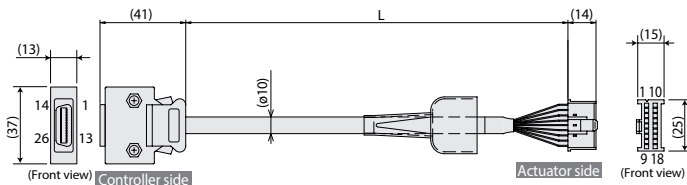

Minimum bending R: r = 50 mm or more (when a robot cable is used)
* If the cable must be guided in a cable track, use a robot cable.

Encoder cable / Encoder robot cable for RCS2-RT6/RT6R/RT7/RA13R

Model: **CB-RCS2-PLA** □□□ / **CB-X2-PLA** □□□

* Enter the cable length (L) into □□□. Compatible to a Maximum of 30 meters.
Ex.: 080 = 8m

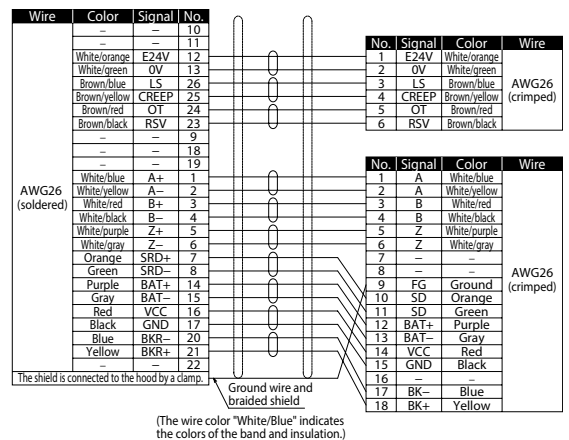
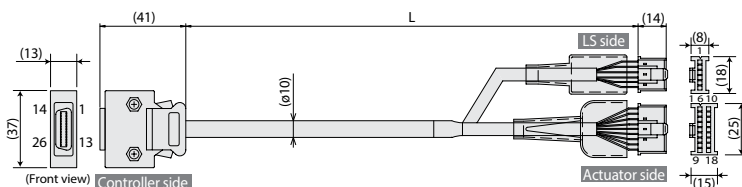

Minimum bending R: r = 50 mm or more (when a robot cable is used)
* If the cable must be guided in a cable track, use a robot cable.

IAI America, Inc.

Headquarters: 2690 W. 237th Street, Torrance, CA 90505 (800) 736-1712

Chicago Office: 1261 Hamilton Parkway, Itasca, IL 60143 (800) 944-0333

Atlanta Office: 1220 Kennestone Circle, Suite 108, Marietta, GA 30066 (888) 354-9470

IAI Industrieroboter GmbH

Ober der Roth 4, D-65824 Schwalbach am Taunus, Germany

www.intelligentactuator.com



The information contained in this product brochure may change without prior notice due to product improvements.