

A Palm-Sized Unit Capable of Driving a Maximum Payload of 1 kg

■ Ultra compact size for installation in a small space

The IX-120/150 assures a maximum work envelope of 300 mm in a small installation space of 47 mm in width and 132 mm in depth, enabling significant size reduction of your production line.

■ Rated load capacity of 0.2 kg and maximum load capacity of 1 kg (*1)

Despite its compact body, the IX-120/150 can transport a 0.2kg load at high speed. It can drive up to 1 kg if the acceleration is reduced.

(*1) The rated load capacity indicates the maximum weight that can be operated at the maximum speed and acceleration. The maximum load capacity indicates the maximum weight that can be transported at lower speed and acceleration.

■ High-speed performance of 0.35 second in cycle time (*2)

Designed for enhanced dynamic performance with a highly rigid body, the IX-120/150 boasts outstanding high-speed performance that is among the best in its class.

(*2) The cycle time is based on reciprocating movements carrying a 0.2-kg load over a horizontal distance of 100 mm and vertical distance of 25 mm.

■ Absolute encoder eliminates the need for home return

The IX-120/150 is equipped with an absolute encoder that retains the current position even after the power is turned off.



Model (Refer to the back cover for the controller model.)

IX	NNN1205	5L	T2	B
Series	Type	Cable length	Applicable controller	Option
IX	NNN1205 : Standard type Arm length 120mm Z-axis 50mm NNN1505 : Standard type Arm length 150mm Z-axis 50mm	5L : 5m	T2 : XSEL-PX/QX	B : Z-axis brake : Z

Note

Even if the power is cut off, the Z-axis will not drop as long as the Z-axis load is within the rated load capacity (0.2 kg). If the Z-axis load exceeds the rating, however, the Z-axis may drop when the power is turned off or an emergency stop is actuated.

Options

■ Flange

Model : IX-FL-4

This flange is used to install a load to the Z-axis shaft of the IX-NNN1205 /IX-NNN1505 (weight: 12 g).

■ Z-Axis Brake

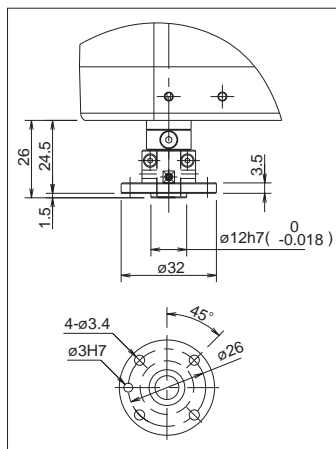

■ Absolute Reset Adjustment Jig

Model : JG-5 (For arm length of 120/150)

This adjustment jig is used when the absolute data in the encoder was lost and an absolute reset must be executed.

■ Teaching Pendant

Model : IA-T-X (Standard)
IA-T-XD (With deadman switch)
IA-T-XA (ANSI/ CE Mark compliant type)

This teaching device supports program/position input, test operation, monitoring, etc.

* IA-T-X/XD of version 1.20 or older and IA-T-XA of version 1.10 or older cannot be used with the PX/QX controllers.

■ Absolute Data Backup Battery

Model : AB-6 (For arm length of 120/150)

This absolute data backup battery allows the current position to be retained even after the power is turned off.

■ PC Software

Model : IA-101-X-MW

With a PC connection cable (D-sub, 9-pin on the PC end): For Windows 95, 98, NT, 2000 and ME.

A startup support tool offering the functions needed to input programs /positions and perform debugging.
* Version 5.0.1.0 or older programs cannot be used with the PX/QX controllers.

IX-NNN1205

Ultra Compact SCARA Robot: Standard Type,
Arm Length 120mm, Vertical Axis 50mm



Type	Standard type	Arm length	120mm	Load capacity	0.2kg rated / 1kg maximum
------	---------------	------------	-------	---------------	---------------------------

Model specification items Series Type Cable Length Applicable controller Options

(Example) IX - NNN1205 - 5L - T2 - B

Models/Specifications

Model	Axis configuration		Arm length (mm)	Motor capacity (W)	Work envelope	Positioning repeatability (mm)	Maximum operating speed (Note 1)	Cycle time (sec) (Note 2)	Load capacity (kg) (Note 3)		Axis 3 Push thrust (N)		Axis 4 Allowable load	
	Axis 1	Axis 2							Rated	Maximum	Push mode (Note 4)	Maximum thrust (Note 4)	Allowable inertial moment (kg*m ²)(Note 5)	Allowable torque (N*m)
IX-NNN1205-5L-T2	Arm 1	45	12	±115°	±0.005 (XY)	2053mm/s (Composite speed)	0.35	0.2	1.0	9.8	17.8	0.000386	0.13	
	Arm 2	75	12	±145°										
	Vertical axis	-	12	50mm	±0.010	720mm/s								
	Rotating axis	-	60	±360°	±0.005	1800°/s								

Common Specifications

Encoder type	Absolute
User wiring	8-core, AWG26 cable with shield / Connector: SMP-08V-NC (JST)
User tubing	Air tube (O.D. ø3, I.D. ø2) x 2 (Normal working pressure 0.7MPa)
Alarm indicator (Note 6)	Small red LED indicator x 1 (24VDC must be supplied.)

Operating temperature/humidity	Temperature 0-40°C, humidity 20-85% RH or less (non-condensing)
Robot weight	2.7 kg
Cable length	5L : 5m

Dimensions

You can download CAD drawings from IAI's website.

2D CAD

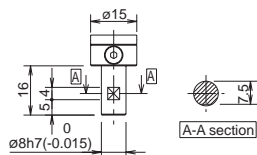

Detail view of vertical axis tip (*3)

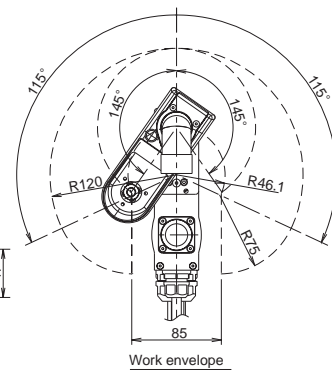
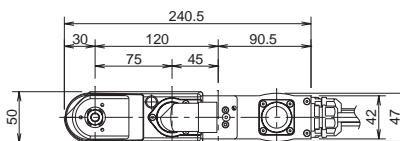

Work envelope

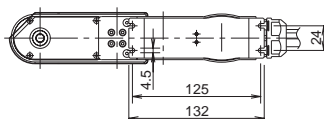
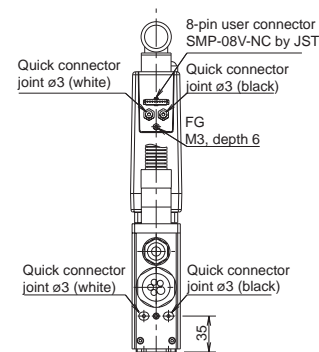
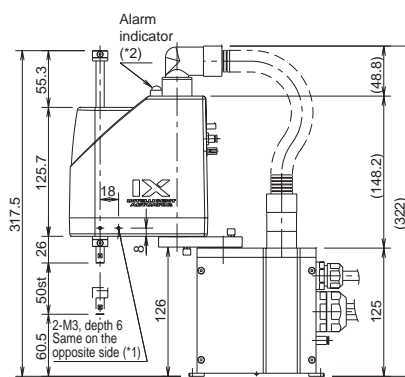
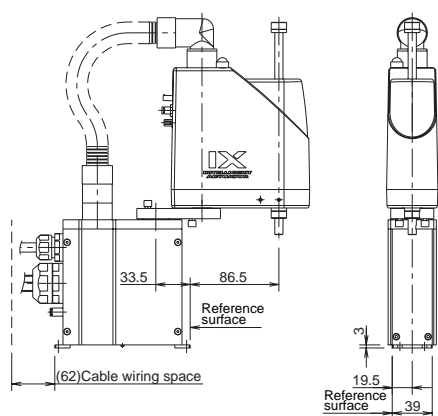

*1: The 2-M3 hole (depth 6) passes through the arm. If the mounting screw is too long, the screw will contact the internal mechanical parts. Exercise caution.

*2: To illuminate the alarm indicator, the user must provide a wiring that uses an I/O output signal from the controller to apply 24 VDC to the LED terminal in the user wiring connector.

*3: The vertical axis does not come with a brake. If the power or servo is turned off, the vertical axis may drop. Exercise caution.

Applicable Controller Specifications

Applicable controller	Feature	Maximum I/O points (input/output)	Power-supply voltage	Page
XSEL-PX	SCARA + 2 robot axes can be controlled.	192 points /192 points	Three-phase 200VAC	→Back cover
XSEL-QX	Conform to safety category 4.			



Caution

- (Note 1) Based on PTP operation. In CP operation, the maximum speed is limited.
- (Note 2) The cycle time is based on reciprocating movements carrying a 0.2-kg load over a horizontal distance of 100 mm and vertical distance of 25 mm.
- (Note 3) The rated load capacity indicates the maximum weight that can be operated at the maximum speed and acceleration. The maximum load capacity indicates the maximum weight that can be transported at lower speed and acceleration.
- (Note 4) The thrust in the push mode indicates the force generated when a push command is executed from the program. The maximum thrust corresponds to the maximum force generated during normal positioning operation.
- (Note 5) The allowable inertial moment indicates an equivalent value measured at the rotational center of axis 4. The offset between the rotational center of axis 4 and the gravity center of the tool must not exceed 17.5 mm.
- (Note 6) To use the alarm indicator, the user must provide a circuit that uses an I/O output or other signal to apply 24 VDC to the LED terminal in the user wiring connector.

IX-NNN1505

Ultra Compact SCARA Robot: Standard Type,
Arm Length 150mm, Vertical Axis 50mm



Type	Standard type	Arm length	150mm	Load capacity	0.2kg rated / 1kg maximum
------	---------------	------------	-------	---------------	---------------------------

Model specification items	Series	Type	Cable Length	Applicable controller	Options
(Example)	IX	NNN1505	5L	T2	B

Models/Specifications

Model	Axis configuration		Arm length (mm)	Motor capacity (W)	Work envelope	Positioning repeatability (mm)	Maximum operating speed (Note 1)	Cycle time (sec) (Note 2)	Load capacity (kg) (Note 3)		Axis 3 Push thrust (N)		Axis 4 Allowable load	
	Axis 1	Axis 2							Rated	Maximum	Push mode (Note 4)	Maximum thrust (Note 4)	Allowable inertial moment (kg·m ² /Note 5)	Allowable torque (N·m)
IX-NNN1505-5L-T2	Arm 1	Arm 2	75	12	-125j	-0.005 (XY)	2304mm/ s (Composite speed)	0.35	0.2	1.0	9.8	17.8	0.000386	0.13
	Axis 2	Axis 3	75	12	-145j	-0.010	720mm/ s							
	Vertical axis	Axis 4	-	60	-360j	-0.005	1800j/ s							
	Rotating axis													

Common Specifications

Encoder type	Absolute
User wiring	8-core, AWG26 cable with shield / Connector: SMP-08V-NC (JST)
User tubing	Air tube (O.D. \varnothing 3, I.D. \varnothing 2) x 2 (Normal working pressure 0.7MPa)
Alarm indicator (Note 6)	Small red LED indicator x 1 (24VDC must be supplied.)

Operating temperature/humidity	Temperature 0-40°C, humidity 20-85% RH or less (non-condensing)
Robot weight	2.7 kg
Cable length	5L : 5m

Dimensions

You can download CAD drawings from IAI's website.

2D CAD

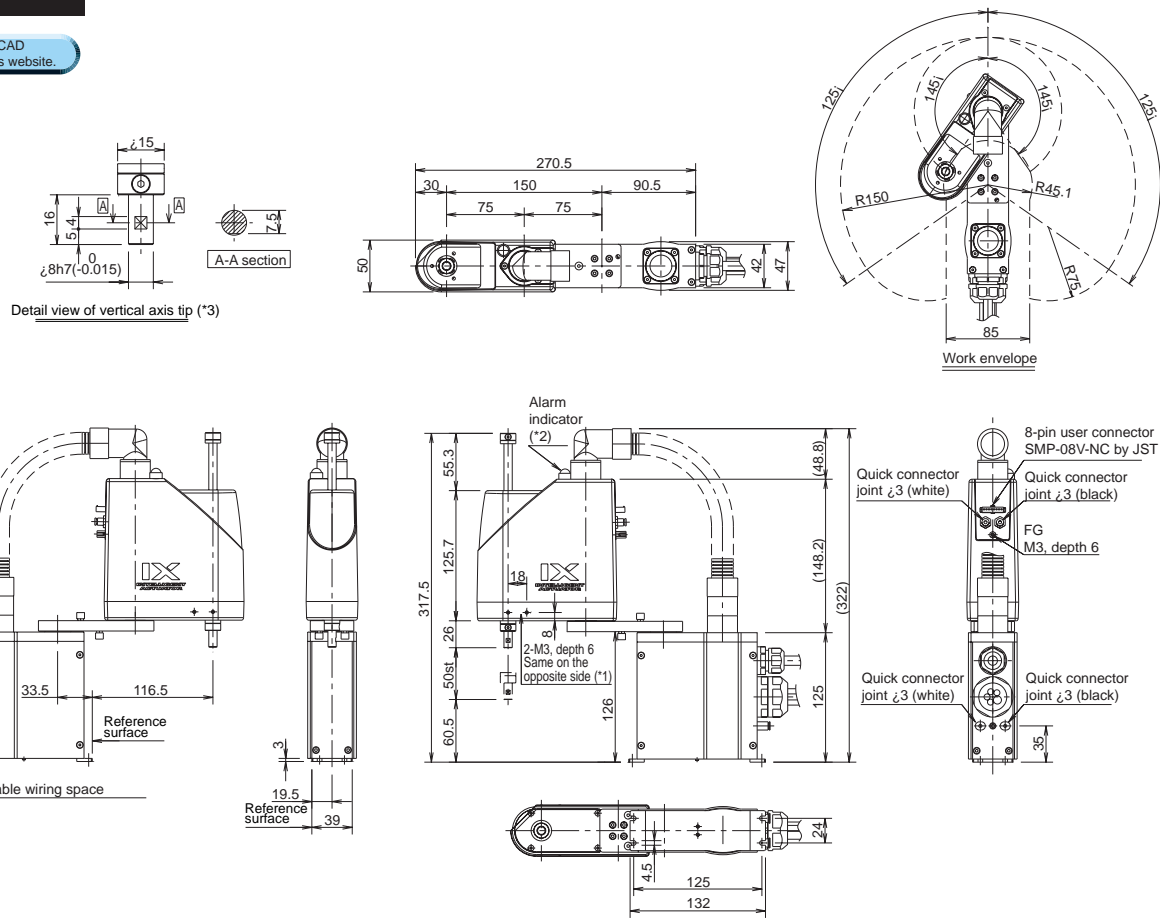

*1: The 2-M3 hole (depth 6) passes through the arm. If the mounting screw is too long, the screw will contact the internal mechanical parts. Exercise caution.
 *2: To illuminate the alarm indicator, the user must provide a wiring that uses an I/O output signal from the controller to apply 24 VDC to the LED terminal in the user wiring connector.
 *3: The vertical axis does not come with a brake. If the power or servo is turned off, the vertical axis may drop. Exercise caution.

Applicable Controller Specifications

Applicable controller	Feature	Maximum I/O points (input/output)	Power-supply voltage	Page
XSEL-PX	SCARA + 2 robot axes can be controlled.	192 points /192 points	Three-phase 200VAC	→Back cover
XSEL-QX	Conform to safety category 4.			

Caution

(Note 1) Based on PTP operation. In CP operation, the maximum speed is limited.
 (Note 2) The cycle time is based on reciprocating movements carrying a 0.2-kg load over a horizontal distance of 100 mm and vertical distance of 25 mm.
 (Note 3) The rated load capacity indicates the maximum weight that can be operated at the maximum speed and acceleration. The maximum load capacity indicates the maximum weight that can be transported at lower speed and acceleration.
 (Note 4) The thrust in the push mode indicates the force generated when a push command is executed from the program. The maximum thrust corresponds to the maximum force generated during normal positioning operation.
 (Note 5) The allowable inertial moment indicates an equivalent value measured at the rotational center of axis 4. The offset between the rotational center of axis 4 and the gravity center of the tool must not exceed 17.5 mm.
 (Note 6) To use the alarm indicator, the user must provide a circuit that uses an I/O output or other signal to apply 24 VDC to the LED terminal in the user wiring connector.

