

# ERC3CR-SA7C

Cleanroom ROBO Cylinder, Slider Type, Coupled, Actuator Width 73mm, Pulse Motor, Controller-Integrated

Model Specification Items	<b>ERC3CR-SA7C</b>	<b>I</b>	<b>56P</b>							
Series	Type	Encoder type	Motor type	Lead	Stroke	I/O type	Cable length	Controller type	Options	
		I: Incremental specification	56□: Pulse motor	24: 24mm 16: 16mm 8: 8mm 4: 4mm	50: 50mm ? 800: 800mm (50mm pitch increments)	NP: PIO (NPN) type PN: PIO (PNP) type SE: SIO type PLN: Pulse-train (NPN) type PLP: Pulse-train (PNP) type	N: None P: 1m S: 3m M: 5m X□□: Custom Length	CN: CON type MC: MEC type	See Options below.	

\* See page Pre-47 for details on the model descriptions.



Technical References Appendix P.5



- (1) If the high-output setting is enabled (factory default), the duty must be limited. (Refer to page A-95.) If the high-output setting is disabled, the payload and maximum speed become lower, but the actuator can be used at a duty of 100%. Refer to the operation manual for information on how to change the high-output setting.
- (2) Refer to page A-99 for the payload at each speed/acceleration when the high-output setting is enabled.

### Speed vs. Load Capacity

Due to the characteristics of the pulse motor, the ERC3 series' load capacity decreases at high speeds. In the table below, check if your desired speed and load capacity are supported.

The values below are based on operation at 0.3 G.

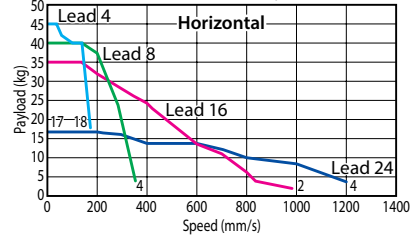

The values below are based on operation at 0.3 G.

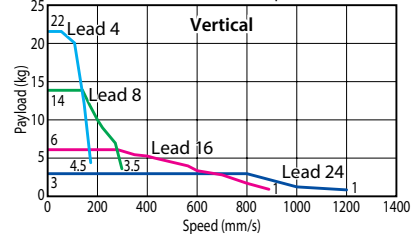

High-output setting enabled (Factory default)

### Actuator Specifications (High-output Setting Enabled)

#### Lead and Payload

(Note 1) Take caution that the maximum payload decreases as the speed increases.

Model number	Lead (mm)	Maximum payload (Note 1)		Stroke (mm)
		Horizontal (kg)	Vertical (kg)	
ERC3CR-SA7C-I-56P-24-①-②-③-④	24	17	3	50~800 (every 50mm)
ERC3CR-SA7C-I-56P-16-①-②-③-④	16	35	6	
ERC3CR-SA7C-I-56P-8-①-②-③-④	8	40	14	
ERC3CR-SA7C-I-56P-4-①-②-③-④	4	45	22	

Code explanation ① Stroke ② I/O type ③ Cable length ④ Options

#### Stroke and Max. Speed/Suction Volume by Lead

(Unit: mm/s)

Stroke Lead	50~550 (everymm)	600 (mm)	650 (mm)	700 (mm)	750 (mm)	800 (mm)	Suction amount (Nℓ/min)
24	1200	1155	1010	890	790	90	
16	980 <840>	865 <840>	750	655	580	515	70
8	490	430	375	325	290	255	40
4	210	185	160	145	125	30	

\* The values enclosed in < > apply to vertical settings.

\* The values of lead 8 and lead 4 apply when acceleration is at 0.1G.

#### ① Stroke

Stroke (mm)	Standard price	Stroke (mm)	Standard price
50	—	450	—
100	—	500	—
150	—	550	—
200	—	600	—
250	—	650	—
300	—	700	—
350	—	750	—
400	—	800	—

#### ④ Options

Name	Option code	See page	Standard price
Brake	<b>B</b>	→ A-42	—
Non-motor end specification	<b>NM</b>	→ A-52	—
Vacuum port on opposite side	<b>VR</b>	→ A-58	—
Simple absolute specification	<b>ABU</b>	→ A-42	— (*)

(\*) If the simple absolute specification is selected, the separately sold PIO converter of simple absolute specification (with battery) is required and the SIO type of ERC3 must be selected.

#### ③ Cable Length

Type	Cable symbol	Standard price	
		PIO type	SIO type
Standard (Robot Cables)	<b>P</b> (1m)	—	—
	<b>S</b> (3m)	—	—
	<b>M</b> (5m)	—	—
Special length	<b>X06</b> (6m) ~ <b>X10</b> (10m)	—	—

\* See page 586 for cables for maintenance.

### Actuator Specifications

Item	Description
Drive system	Ball screw, ø12mm, rolled C10
Positioning repeatability (*1)	± 0.02mm [± 0.03mm]
Lost motion	0.1mm or less
Allowable static load moment	Ma: 50.4 N·m, Mb: 71.9 N·m, Mc: 138.0 N·m
Allowable dynamic load moment (*2)	Ma: 13.9 N·m, Mb: 19.9 N·m, Mc: 38.3 N·m
Overhang load length	Ma direction: 230mm or less Mb/Mc directions: 230mm or less
Cleanliness	Class 10 (0.1µm)
Ambient operating temperature/humidity	0 to 40°C, 85% RH max. (Non-condensing)

(\*1) The specification in [ ] applies when the lead is 24mm.

(\*2) Based on 5,000 km of traveling life.

Direction of allowable load moment.

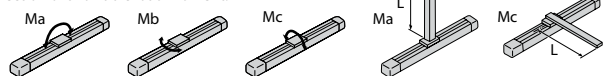

Dimensional Drawings

CAD drawings can be downloaded from the website. [www.intelligentactuator.com](http://www.intelligentactuator.com)



For Special Orders Appendix P.15

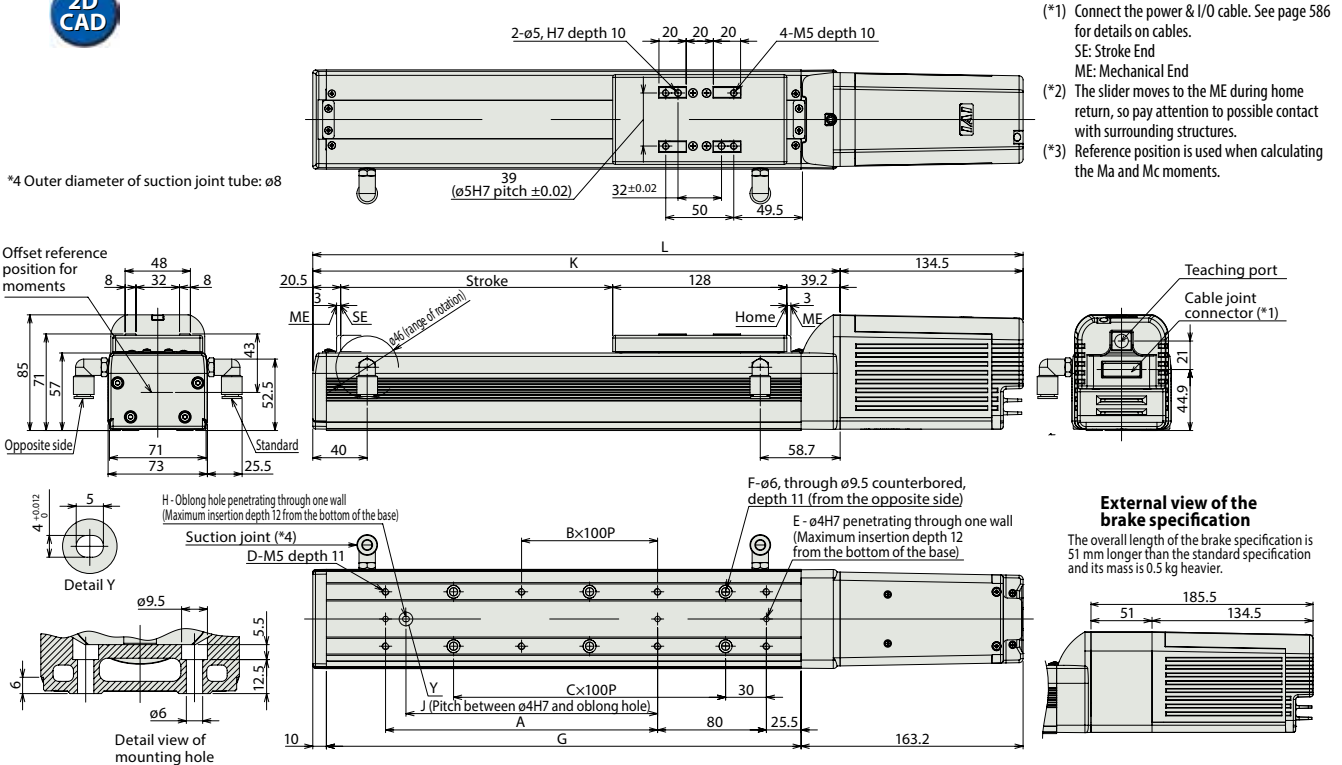

Dimensions and Weight by Stroke

Stroke	50	100	150	200	250	300	350	400	450	500	550	600	650	700	750	800
L	372.2	422.2	472.2	522.2	572.2	622.2	672.2	722.2	772.2	822.2	872.2	922.2	972.2	1022.2	1072.2	1122.2
A	0	100	100	200	200	300	300	400	400	500	500	600	600	700	700	800
B	0	0	0	1	1	2	2	3	3	4	4	5	5	6	6	7
C	1	1	2	2	3	3	4	4	5	5	6	6	7	7	8	8
D	4	6	6	8	8	10	10	12	12	14	14	16	16	18	18	20
E	2	3	3	3	3	3	3	3	3	3	3	3	3	3	3	3
F	4	4	6	6	8	8	10	10	12	12	14	14	16	16	18	18
G	199	249	299	349	399	449	499	549	599	649	699	749	799	849	899	949
H	0	1	1	1	1	1	1	1	1	1	1	1	1	1	1	1
J	0	85	85	185	185	285	285	385	385	485	485	585	585	685	685	785
K	237.7	287.7	337.7	387.7	437.7	487.7	537.7	587.7	637.7	687.7	737.7	787.7	837.7	887.7	937.7	987.7
Weight (kg)	3.6	3.9	4.1	4.4	4.7	4.9	5.2	5.5	6.0	6.0	6.3	6.5	6.8	7.1	7.3	7.6

Controllers (Built into the Actuator)

I/O type

With the ERC3 series, one of the following five types of built-in controllers can be selected depending on the external input/output (I/O) type. Select the type that meets your purpose.

Name	External view	Model number	Features	Maximum number of positioning points	Input power	Power-supply capacity	Standard price	Reference page
PIO type (NPN specification)		ERC3CR-SA7C-I-56P-□-□-NP-□-□	Simple control type accommodating up to 16 positioning points	16 points	DC24V	High-output setting enabled: 3.5A rated 4.2A max. High-output setting disabled: 2.2A	—	→ P577
PIO type (PNP specification)		ERC3CR-SA7C-I-56P-□-□-PN-□-□	I/O type supporting inputs/outputs of the PNP specification often used overseas	16 points				
SIO type		ERC3CR-SA7C-I-56P-□-□-SE-□-□	High-function type accommodating up to 512 positioning points (PIO converter is used)	512 points				
Pulse-train type (NPN specification)		ERC3CR-SA7C-I-56P-□-□-PLN-□-□	Pulse-train input type supporting the NPN specification	—				
Pulse-train type (PNP specification)		ERC3CR-SA7C-I-56P-□-□-PLP-□-□	Pulse-train input type supporting the PNP specification	—				