

RCS2-RA4R

Robo Cylinder, Rod Type, ø37mm Diameter, 200V Servo Motor, Side-mounted Motor

Model Specification Items	RCS2 — RA4R —	Encoder type	Motor type	Lead	Stroke	Applicable controller	Cable length	Options
	Series — Type	1: Incremental A: Absolute	20: 20W Servo motor 30: 30W Servo motor	12: 12mm 6: 6mm 3: 3mm	50: 50mm 300: 300mm (50mm pitch increments)	T1: XSEL-J/K T2: SCON MSCON SSEL XSEL-P/Q XSEL-R/S	N: None P: 1m S: 3m M: 5m X□□: Custom Length R□□: Robot Cable	See options below.

* See page Pre-47 for details on the model descriptions.



*CE compliance is optional.



Technical References Appendix P.5

- POINT**
Notes on selection
- (1) When the stroke increases, the maximum speed will drop to prevent the ball screw from reaching the critical rotational speed. Use the actuator specification table below to check the maximum speed at the stroke you desire.
 - (2) The load capacity is based on operation at an acceleration of 0.3G (0.2G for 3mm-lead model). This is the upper limit of the acceleration.
 - (3) The values for the horizontal load capacity assume the use of an external guide, so that there is no external force from any direction other than the forward/backward direction of the rod.
 - (4) See page A-71 for details on push motion.

Actuator Specifications

Leads and Payloads

Model number	Motor output (W)	Lead (mm)	Max. Load Capacity		Rated thrust (N)	Stroke (mm)
			Horizontal (kg)	Vertical (kg)		
RCS2-RA4R-①-20-12-②-③-④-⑤	20	12	3.0	1.0	18.9	50~300 (every 50mm)
RCS2-RA4R-①-20-6-②-③-④-⑤		6	6.0	2.0	37.7	
RCS2-RA4R-①-20-3-②-③-④-⑤		3	12.0	4.0	75.4	
RCS2-RA4R-①-30-12-②-③-④-⑤	30	12	4.0	1.5	28.3	
RCS2-RA4R-①-30-6-②-③-④-⑤		6	9.0	3.0	56.6	
RCS2-RA4R-①-30-3-②-③-④-⑤		3	18.0	6.5	113.1	

Stroke and Maximum Speed

Lead	Stroke	50~300 (every 50mm)
	12	600
6	300	
3	150	

(Unit: mm/s)

Code explanation ① Encoder ② Stroke ③ Applicable controller ④ Cable length ⑤ Options *See page A-71 for details on push motion.

① Encoder Type/② Stroke

② Stroke (mm)	Standard price			
	① Encoder Type			
	Incremental		Absolute	
	Motor Output (W)		Motor Output (W)	
	20W	30W	20W	30W
50	—	—	—	—
100	—	—	—	—
150	—	—	—	—
200	—	—	—	—
250	—	—	—	—
300	—	—	—	—

⑤ Options

Name	Option code	See page	Standard price
Brake	B	→ A-42	—
CE compliance	CE	→ A-42	—
Foot bracket	FT	→ A-49	—
Flange bracket (front)	FL	→ A-45	—
Flange bracket (back)	FLR	→ A-46	—
Home sensor	HS	→ A-50	—
Knuckle joint	NJ	→ A-53	—
Non-motor end specification	NM	→ A-52	—
Clevis bracket	QR	→ A-53	—
Back-mounting plate	RP	→ A-54	—
Trunnion bracket (front)	TRF	→ A-57	—

*The home sensor (HS) cannot be used on the non-motor end models.

④ Cable Length

Type	Cable symbol	Standard Price
Standard	P (1m)	—
	S (3m)	—
	M (5m)	—
Special length	X06 (6m) ~ X10 (10m)	—
	X11 (11m) ~ X15 (15m)	—
	X16 (16m) ~ X20 (20m)	—
	R01 (1m) ~ R03 (3m)	—
Robot Cable	R04 (4m) ~ R05 (5m)	—
	R06 (6m) ~ R10 (10m)	—
	R11 (11m) ~ R15 (15m)	—
	R16 (16m) ~ R20 (20m)	—

* See page A-59 for cables for maintenance.

Actuator Specifications

Item	Description
Drive System	Ball screw, ø10mm, rolled C10
Positioning Repeatability	±0.02mm
Lost Motion	0.1mm or less
Base	Material: Aluminum, white alumite treated
Rod diameter	ø20mm
Non-rotating accuracy of rod	±1.0 deg
Ambient operating temperature, humidity	0 to 40°C, 85% RH or less (Non-condensing)

- Slider Type
- Mini
- Standard
- Controllers Integrated
- Rod Type
- Mini
- Standard
- Controllers Integrated
- Table/ Arm/ Flat Type
- Mini
- Standard
- Gripper/ Rotary Type
- Linear Servo Type
- Clean-room Type
- Splash-Proof Type
- Pulse Motor
- Servo Motor (24V)
- Servo Motor (200V)
- Linear Servo Motor

Dimensional Drawings

CAD drawings can be downloaded from the website. www.intelligentactuator.com

For Special Orders Appendix P.15



[No Brake]

Note:
Do not apply any external force on the rod from any direction other than the direction of the rod's motion. If a force is exerted on the rod in a perpendicular or rotational direction, the detent may become damaged.

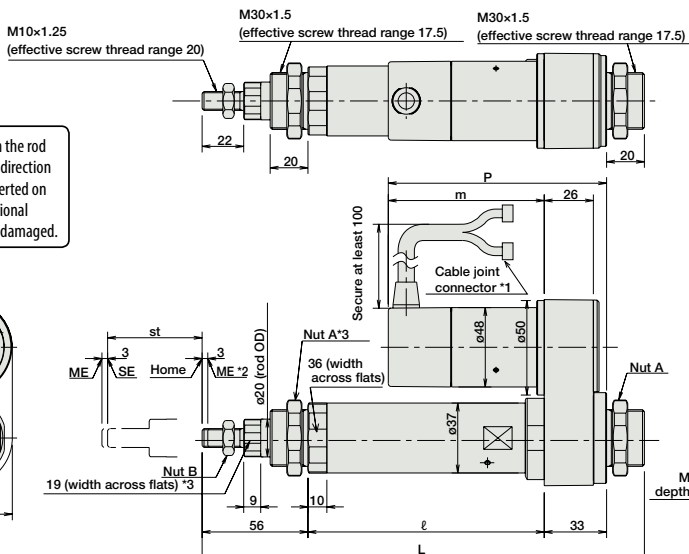

- (*1) Connect the motor and encoder cables here. See page A-59 for details on cables.
- (*2) After homing, the slider moves to the ME, therefore, please watch for any interference with surrounding objects.
ME: Mechanical end SE: Stroke end
- (*3) The orientation of the bolt varies depending on the product.

[Brake-Equipped]

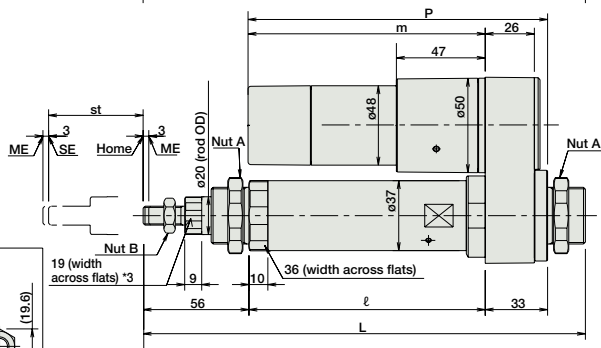
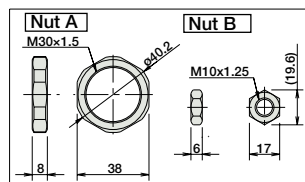

Dimensions and Weight by Stroke

RCS2-RA4R (without brake)

Stroke	50	100	150	200	250	300	
L	20W	234	284	334	384	434	484
	30W	234	284	334	384	434	484
	ℓ	125	175	225	275	325	375
m	20W	80.5					
	30W	95.5					
p	20W	113.5					
	30W	128.5					
Weight (kg)	1.2	1.4	1.5	1.7	1.8	2.0	

RCS2-RA4R (with brake)

Stroke	50	100	150	200	250	300	
L	20W	234	284	334	384	434	484
	30W	234	284	334	384	434	484
	ℓ	125	175	225	275	325	375
m	20W	123.5					
	30W	138.5					
p	20W	156.5					
	30W	171.5					
Weight (kg)	1.4	1.6	1.7	1.9	2.0	2.2	

Applicable Controllers

RCS2-series actuators can be operated with the following controllers. Select an appropriate controller type according to your application.

Name	External view	Model number	Features	Maximum number of positioning points	Input power	Power supply capacity	Standard price	Reference page	
Positioner mode		SCON-CA-20①-NP-2-② SCON-CA-30D①-NP-2-②	Up to 512 positioning points are supported.	512 points	Single-phase 100VAC Single-phase 200VAC 3-phase 200VAC (XSEL-P/Q/R/S ONLY)	126 VA max. *Power supply capacity will vary depending on the controller, so please refer to the instruction manual for details.	—	→ P643	
Solenoid valve mode			Actuators can be operated through the same control used for solenoid valves.	7 points					
Field network type			Movement by numerical specification is supported.	768 points					
Pulse-train input control type			Dedicated pulse-train input type	(—)					
Positioner multi-axis, network type		MSCON-C-1-20①-④-0-② MSCON-C-1-30D①-④-0-②	Up to 6 axes can be operated. Movement by numerical specification is supported.	256 points	—	—	→ P655		
Program control type, 1 to 2 axes		SSEL-CS-1-20①-NP-2-② SSEL-CS-1-30D①-NP-2-②	Program operation is supported. Up to 2 axes can be operated.	20,000 points				—	→ P685
Program control type, 1 to 8 axes		XSEL-③-1-20①-N1-EEE-2-④ XSEL-③-1-30D①-N1-EEE-2-④	Program operation is supported. Up to 8 axes can be operated.	Varies depending on the number of axes connected					

* This is for the single-axis MSCON, SSEL, and XSEL.
 ① indicates the power-supply voltage type (1: 100V / 2: Single-phase 200V).
 ② indicates the power-supply voltage type (1: 100V / 2: Single-phase 200V / 3: Three-phase 200V).
 ③ indicates the encoder type (I: Incremental / A: Absolute).
 ④ indicates the XSEL type (J / K / P / Q / R / S).
 * indicates field network specification symbol.