

RCA-RGD3C

Robo Cylinder, Rod Type with Double Guide, ø32mm Diameter, 24V Servo Motor, Coupled

Model Specification Items	RCA — RGD3C — I — 20 — <input type="checkbox"/> — <input type="checkbox"/> — <input type="checkbox"/> — <input type="checkbox"/> — <input type="checkbox"/>	Series	Type	Encoder type	Motor type	Lead	Stroke	Applicable controller	Cable length	Options
	I: Incremental * The Simple absolute encoder is also considered type "I".	20: 20W Servo motor	10: 10mm 5: 5mm 2.5: 2.5mm	50: 50mm { 200: 200mm (50mm pitch increments)	A1: ACON ASEL A3: AMEC ASEP MSEP	N: None P: 1m S: 3m M: 5m X <input type="checkbox"/> : Custom Length R <input type="checkbox"/> : Robot Cable	See Options below.			

* See page Pre-47 for details on the model descriptions.



For High Acceleration/Deceleration

Power-saving

(excluding the 2.5mm-lead model)

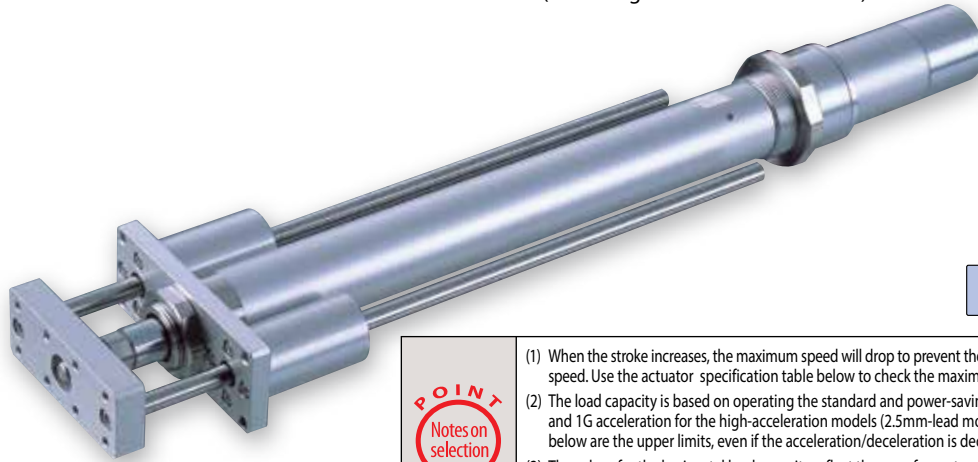

Technical References Appendix P.5



- (1) When the stroke increases, the maximum speed will drop to prevent the ball screw from reaching the critical rotational speed. Use the actuator specification table below to check the maximum speed at the stroke you desire.
- (2) The load capacity is based on operating the standard and power-saving models at 0.3G (0.2G for 2.5mm-lead), and 1G acceleration for the high-acceleration models (2.5mm-lead model excluded). The values in the table below are the upper limits, even if the acceleration/deceleration is decreased.
- (3) The values for the horizontal load capacity reflect the use of an external guide. See the technical resources (page A-112) for the allowable weight using the supplied guide alone.
- (4) See page A-71 for details on push motion.

Actuator Specifications

Leads and Payloads

Model number	Motor output (W)	Lead (mm)	Max. Load Capacity		Rated thrust (N)	Stroke (mm)
			Horizontal (kg)	Vertical (kg)		
RCA-RGD3C-I-20-10- <input type="checkbox"/> - <input type="checkbox"/> - <input type="checkbox"/> - <input type="checkbox"/>	20	10	4.0	1.2	36.2	50~200 (every 50mm)
RCA-RGD3C-I-20-5- <input type="checkbox"/> - <input type="checkbox"/> - <input type="checkbox"/> - <input type="checkbox"/>		5	9.0	2.7	72.4	
RCA-RGD3C-I-20-2.5- <input type="checkbox"/> - <input type="checkbox"/> - <input type="checkbox"/> - <input type="checkbox"/>		2.5	18.0	6.2	144.8	

Stroke and Maximum Speed

Lead	Stroke	50~200 (every 50mm)
	10	500
5	250	250
2.5	125	125

Code explanation Stroke Applicable controller Cable length Options *See page A-71 for details on push motion. (Unit: mm/s)

① Stroke

① Stroke (mm)	Standard price
50	—
100	—
150	—
200	—

③ Cable Length

Type	Cable symbol	Standard Price
Standard	P (1m)	—
	S (3m)	—
	M (5m)	—
Special length	X06 (6m) ~ X10 (10m)	—
	X11 (11m) ~ X15 (15m)	—
	X16 (16m) ~ X20 (20m)	—
Robot Cable	R01 (1m) ~ R03 (3m)	—
	R04 (4m) ~ R05 (5m)	—
	R06 (6m) ~ R10 (10m)	—
	R11 (11m) ~ R15 (15m)	—
	R16 (16m) ~ R20 (20m)	—
	R20 (20m)	—

* See page A-59 for cables for maintenance.

④ Options

Name	Option code	See page	Standard price
Brake	B	→ A-42	—
Foot bracket	FT	→ A-49	—
High-acceleration/deceleration (*1)	HA	→ A-50	—
Home sensor (*2)	HS	→ A-50	—
Power-saving (*3)	LA	→ A-52	—
Non-motor end specification	NM	→ A-52	—
Trunnion bracket (back)	TRR	→ A-58	—

(*1) The high-acceleration/deceleration option is not available for 2.5mm-lead model.

(*2) The home sensor (HS) cannot be used on the non-motor end models.

(*3) The high-acceleration/deceleration option and the power-saving option cannot be used simultaneously.

Actuator Specifications

Item	Description
Drive System	Ball screw, ø8mm, rolled C10
Positioning Repeatability	±0.02mm
Lost Motion	0.1mm or less
Guide	Single guide (guide rod diameter ø8mm, Ball bush type)
Rod diameter	ø16mm
Non-rotating accuracy of rod	±0.05 deg
Ambient operating temperature, humidity	0 to 40°C, 85% RH or less (Non-condensing)

Dimensional Drawings

CAD drawings can be downloaded from the website.

www.intelligentactuator.com

For Special Orders

Appendix P.15



- (*1) Connect the motor and encoder cables here. See page A-59 for details on cables.
- (*2) After homing, the slider moves to the ME, therefore, please watch for any interference with surrounding objects.

ME : Mechanical end SE : Stroke end

[No Brake]

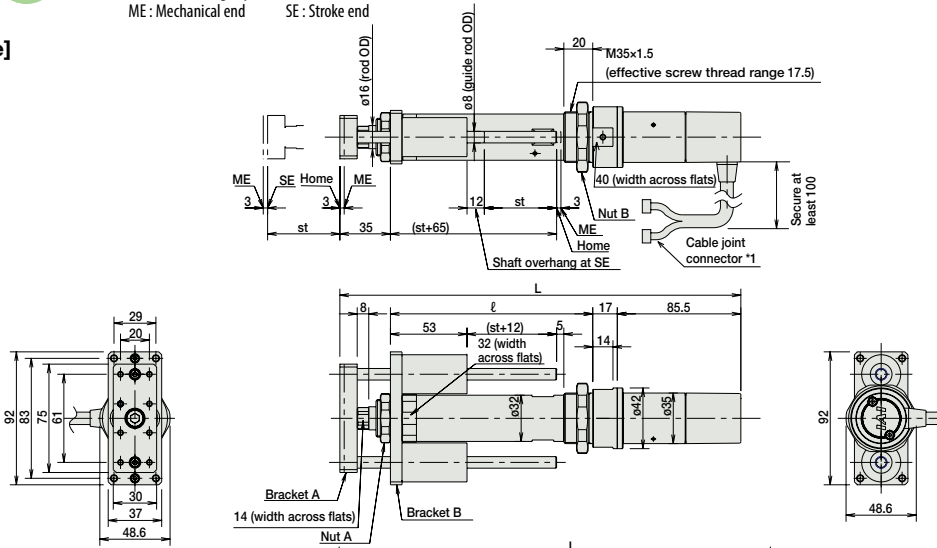

[Brake-Equipped]

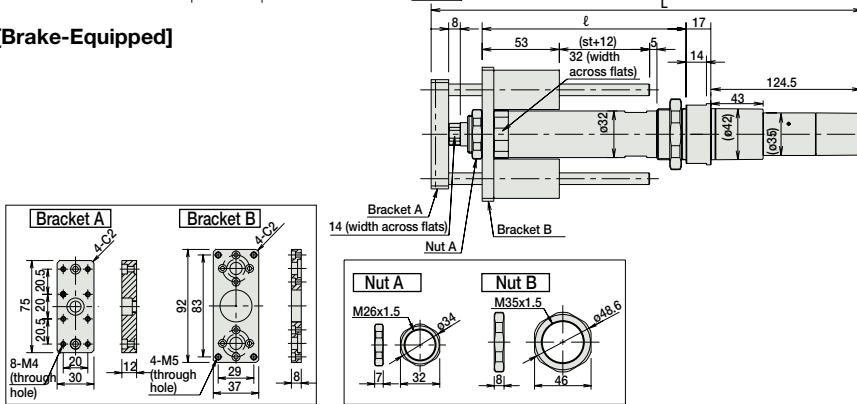

Dimensions and Weight by Stroke
RCA-RGD3C (without brake)

Stroke	50	100	150	200
L	277.5	327.5	377.5	427.5
ℓ	140	190	240	290
Weight (kg)	1.1	1.2	1.4	1.5

RCA-RGD3C (with brake)

Stroke	50	100	150	200
L	316.5	366.5	416.5	466.5
ℓ	140	190	240	290
Weight (kg)	1.3	1.4	1.6	1.7

Applicable Controllers

RCA series actuators can be operated with the controllers indicated below. Select the type according to your intended application. * ACON-CY also can be used.

Name	External view	Model number	Features	Maximum number of positioning points	Input power	Power-supply capacity	Standard price	Reference page
Solenoid Valve Type		AMEC-C-20SI①-②-2-1	Easy-to-use controller, even for beginners	3 points	AC100V	2.4A rated	—	→ P537
		ASEP-C-20SI①-②-2-0	Simple controller operable with the same signal as a solenoid valve					→ P547
Solenoid valve multi-axis type PIO specification		MSEP-C-③-④-⑤-2-0	Positioner type based on PIO control, allowing up to 8 axes to be connected	256 points	DC24V	(Standard) 1.7A rated 5.1A max.	—	→ P563
Solenoid valve multi-axis type Network specification		MSEP-C-③-④-⑤-0-0	Field network-ready positioner type, allowing up to 8 axes to be connected					
Positioner type		ACON-C-20SI①-②-2-0	Positioning is possible for up to 512 points	512 points	DC24V	(Power-saving) 1.7A rated 3.4A max.	—	→ P631
Safety-Compliant Positioner Type		ACON-CG-20SI①-②-2-0						
Pulse Train Input Type (Differential Line Driver)		ACON-PL-20SI①-②-2-0	Pulse train input type with differential line driver support	(—)	DC24V	(Power-saving) 1.7A rated 3.4A max.	—	→ P631
Pulse Train Input Type (Open Collector)		ACON-PO-20SI①-②-2-0	Pulse train input type with open collector support					
Serial Communication Type		ACON-SE-20SI①-N-0-0	Dedicated Serial Communication	64 points	DC24V	(Power-saving) 1.7A rated 3.4A max.	—	→ P675
Program Control Type		ASEL-CS-1-20SI①-②-2-0	Programmed operation is possible. Can operate up to 2 axes	1,500 points	DC24V	(Power-saving) 1.7A rated 3.4A max.	—	→ P675

* This is for the single-axis ASEL. * Enter the code "HA" or "LA" in ① when the high-acceleration/deceleration option or the power-saving option is specified.
 * ① indicates I/O type (NP/PN). * ② indicates number of axes (1 to 8). * ④ indicates field network specification symbol.

Slider Type

Mini

Standard

Controllers Integrated

Rod Type

Mini

Standard

Controllers Integrated

Table/ Arm/ Flat Type

Mini

Standard

Gripper/ Rotary Type

Linear Servo Type

Clean-room Type

Splash-Proof Type

Pulse Motor

Servo Motor (24V)

Servo Motor (200V)

Linear Servo Motor