

RCA-RGS4D

Robo Cylinder, Rod Type with Single Guide, ø37mm Diameter, 24V Servo Motor, Built-In Model

Model Specification Items	RCA	-RGS4D-							
	Series	Type	Encoder type	Motor type	Lead	Stroke	Applicable controller	Cable length	Options
			I: Incremental A: Absolute <small>* Absolute encoder models can only use ASEL. When the actuator is used with the simple absolute encoder, the model is considered an incremental model.</small>	20: 20W Servo motor 30: 30W Servo motor	12: 12mm 6: 6mm 3: 3mm	50: 50mm 300: 300mm (50mm pitch increments)	A1: ACON ASEL A3: AMEC ASEP MSEP	N: None P: 1m S: 3m M: 5m X□□: Custom Length R□□: Robot Cable	See Options below.

* See page Pre-47 for details on the model descriptions.

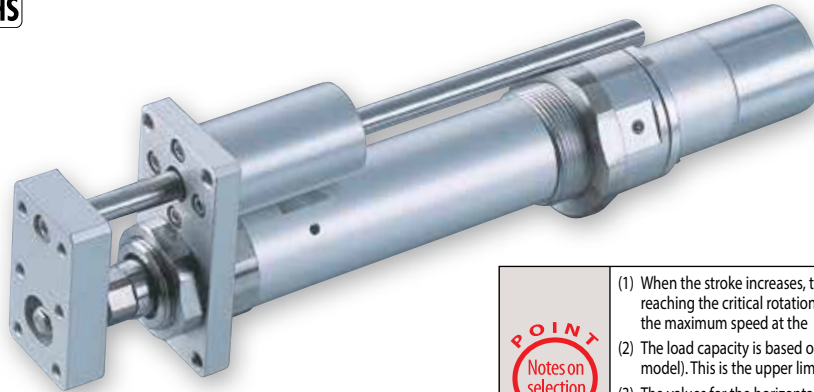

Power-saving

Technical References Appendix P.5

- POINT**
Notes on selection
- When the stroke increases, the maximum speed will drop to prevent the ball screw from reaching the critical rotational speed. Use the actuator specification table below to check the maximum speed at the stroke you desire.
 - The load capacity is based on operation at an acceleration of 0.3G (0.2G for the 3mm-lead model). This is the upper limit of the acceleration.
 - The values for the horizontal load capacity reflect the use of an external guide. See the technical resources (page A-111) for the allowable weight using the supplied guide alone.
 - See page A-71 for details on push motion.

Actuator Specifications

Leads and Payloads

Model number	Motor output (W)	Lead (mm)	Max. Load Capacity		Rated thrust (N)	Stroke (mm)
			Horizontal (kg)	Vertical (kg)		
RCA-RGS4D-①-20-12-②-③-④-⑤	20	12	3.0	0.5	18.9	50~300 (every 50mm)
RCA-RGS4D-①-20-6-②-③-④-⑤		6	6.0	1.5	37.7	
RCA-RGS4D-①-20-3-②-③-④-⑤		3	12.0	3.5	75.4	
RCA-RGS4D-①-30-12-②-③-④-⑤	30	12	4.0	1.0	28.3	
RCA-RGS4D-①-30-6-②-③-④-⑤		6	9.0	2.5	56.6	
RCA-RGS4D-①-30-3-②-③-④-⑤		3	18.0	6.0	113.1	

Stroke and Maximum Speed

Lead	Stroke	50~300 (every 50mm)
	12	
6		300
3		150

(Unit: mm/s)

Code explanation ① Encoder ② Stroke ③ Applicable controller ④ Cable length ⑤ Options *See page A-71 for details on push motion.

① Stroke

② Stroke (mm)	Standard price			
	① Encoder Type			
	Incremental		Absolute	
	Motor Output (W)		Motor Output (W)	
	20W	30W	20W	30W
50	—	—	—	—
100	—	—	—	—
150	—	—	—	—
200	—	—	—	—
250	—	—	—	—
300	—	—	—	—

④ Cable Length

Type	Cable symbol	Standard Price
Standard	P (1m)	—
	S (3m)	—
	M (5m)	—
Special length	X06 (6m) ~ X10 (10m)	—
	X11 (11m) ~ X15 (15m)	—
	X16 (16m) ~ X20 (20m)	—
Robot Cable	R01 (1m) ~ R03 (3m)	—
	R04 (4m) ~ R05 (5m)	—
	R06 (6m) ~ R10 (10m)	—
	R11 (11m) ~ R15 (15m)	—
	R16 (16m) ~ R20 (20m)	—

* See page A-59 for cables for maintenance.

⑤ Options

Name	Option code	See page	Standard price
Foot bracket	FT	→ A-49	—
Home sensor	HS	→ A-50	—
Power-saving	LA	→ A-52	—
Non-motor end specification	NM	→ A-52	—
Trunnion bracket (back)	TRR	→ A-58	—

*The home sensor (HS) cannot be used on the non-motor end models.

Actuator Specifications

Item	Description
Drive System	Ball screw, ø10mm, rolled C10
Positioning Repeatability	±0.02mm
Lost Motion	0.1mm or less
Guide	Single guide (guide rod diameter ø10mm, Ball bush type)
Rod diameter	ø20mm
Non-rotating accuracy of rod	±0.05 deg
Ambient operating temperature, humidity	0 to 40°C, 85% RH or less (Non-condensing)

Dimensional Drawings

CAD drawings can be downloaded from the website. www.intelligentactuator.com

For Special Orders Appendix P.15



[No Brake]

- (*1) Connect the motor and encoder cables here. See page A-59 for details on cables.
- (*2) After homing, the slider moves to the ME, therefore, please watch for any interference with surrounding objects.
ME : Mechanical end SE : Stroke end

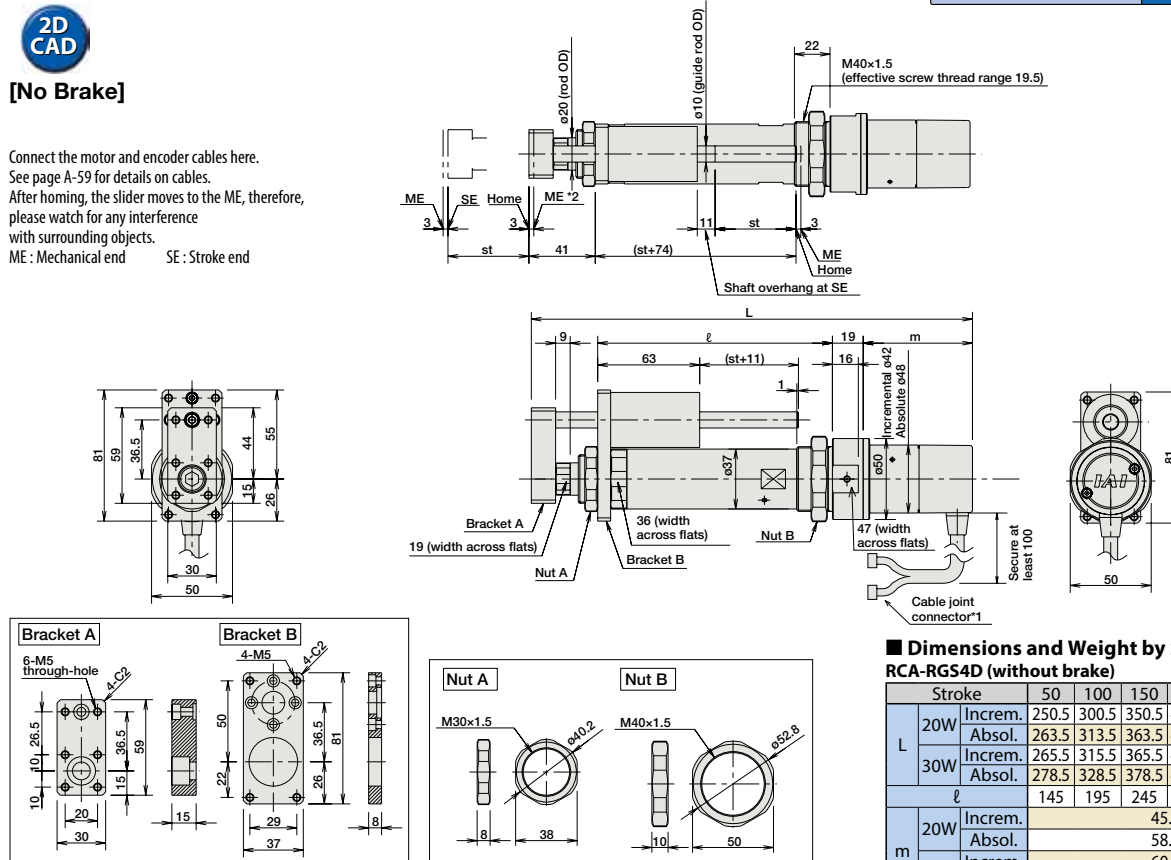

■ Dimensions and Weight by Stroke
RCA-RGS4D (without brake)

Stroke	Weight (kg)							
	50	100	150	200	250	300		
L	20W	Increm.	250.5	300.5	350.5	400.5	450.5	500.5
		Absol.	263.5	313.5	363.5	413.5	463.5	513.5
	30W	Increm.	265.5	315.5	365.5	415.5	465.5	515.5
		Absol.	278.5	328.5	378.5	428.5	478.5	528.5
ℓ			145	195	245	295	345	395
m	20W	Increm.	45.5					
		Absol.	58.5					
	30W	Increm.	60.5					
		Absol.	73.5					
Weight (kg)			1.3	1.5	1.7	1.9	2.1	2.3

RCA-RGS4D models are not equipped with a brake.

③ Applicable Controllers

RCA series actuators can be operated with the controllers indicated below. Select the type according to your intended application. * ACON-CY also can be used.

Name	External view	Model number	Features	Maximum number of positioning points	Input power	Power-supply capacity	Standard price	Reference page
Solenoid Valve Type		AMEC-C-20I(①)-(②)-2-1 AMEC-C-30I(①)-(②)-2-1	Easy-to-use controller, even for beginners	3 points	AC100V	2.4A rated	—	→ P537
		ASEP-C-20I(①)-(②)-2-0 ASEP-C-30I(①)-(②)-2-0	Simple controller operable with the same signal as a solenoid valve					→ P547
Solenoid valve multi-axis type PIO specification		MSEP-C-(Ⅳ)-(Ⅴ)-(Ⅵ)-2-0	Positioner type based on PIO control, allowing up to 8 axes to be connected	256 points	DC24V	(Standard) 20W 1.3A rated 4.4A max. 30W 1.3A rated 4.4A max.	—	→ P563
Solenoid valve multi-axis type Network specification		MSEP-C-(Ⅳ)-(Ⅴ)-(Ⅵ)-0-0	Field network-ready positioner type, allowing up to 8 axes to be connected	512 points				→ P631
Positioner type		ACON-C-20I(①)-(②)-2-0 ACON-C-30I(①)-(②)-2-0	Positioning is possible for up to 512 points	(—)	DC24V	(Power-saving) 20W 1.3A rated 2.5A max. 30W 1.3A rated 2.2A max.	—	→ P631
Safety-Compliant Positioner Type		ACON-CG-20I(①)-(②)-2-0 ACON-CG-30I(①)-(②)-2-0						
Pulse Train Input Type (Differential Line Driver)		ACON-PL-20I(①)-(②)-2-0 ACON-PL-30I(①)-(②)-2-0	Pulse train input type with differential line driver support	(—)	DC24V	(Power-saving) 20W 1.3A rated 2.5A max. 30W 1.3A rated 2.2A max.	—	→ P631
Pulse Train Input Type (Open Collector)		ACON-PO-20I(①)-(②)-2-0 ACON-PO-30I(①)-(②)-2-0	Pulse train input type with open collector support					
Serial Communication Type		ACON-SE-20I(①)-N-0-0 ACON-SE-30I(①)-N-0-0	Dedicated Serial Communication	64 points	DC24V	(Power-saving) 20W 1.3A rated 2.5A max. 30W 1.3A rated 2.2A max.	—	→ P631
Program Control Type		ASEL-CS-1-20I(①)-(②)-2-0 ASEL-CS-1-30I(①)-(②)-2-0	Programmed operation is possible. Can operate up to 2 axes	1,500 points	DC24V	(Power-saving) 20W 1.3A rated 2.5A max. 30W 1.3A rated 2.2A max.	—	→ P675

* This is for the single-axis ASEL. * ① indicates encoder type (I: incremental, A: absolute) * Enter the code "LA" in ① when the power-saving specification is specified.
 * ② indicates I/O type (NP/PN). * Ⅳ indicates number of axes (1 to 8). * Ⅴ indicates field network specification symbol.