

ERC2-RGD7C

Controller-integrated, Rod Type with Double Guide, Actuator Width 68mm, Pulse Motor, Straight Type

Model Specification Items	ERC2	RGD7C	I	PM					
	Series	Type	Encoder type	Motor type	Lead	Stroke	I/O type	Cable length	Options
			I: Incremental	PM: Pulse motor	16: 16mm 8: 8mm 4: 4mm	50: 50mm ? : 300: 300mm (50mm pitch increments)	NP: PLO (NPN) type PN: PLO (PNP) type SE: SIO type	N : None S : 3m M : 5m X□□: Custom W□□: Double-ended cable R□□: Robot cable RW□□: Double-ended Robot cable	P : 1m M : 5m See Options below.

* See page Pre-47 for details on the model descriptions.

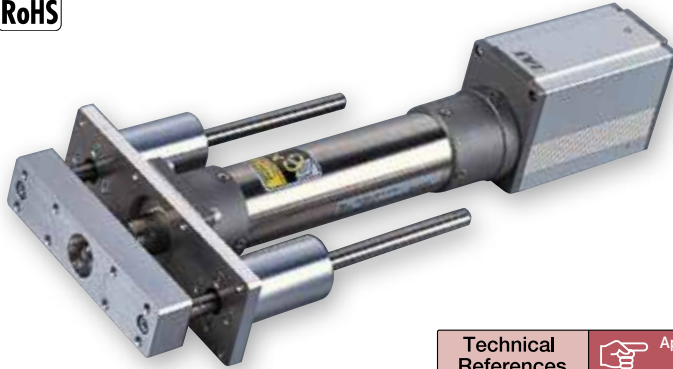

Technical References Appendix P.5

- POINT**
Notes on Selection
- (1) When the stroke increases, the maximum speed will drop to prevent the ball screw from reaching the critical rotational speed. Use the actuator specification table below to check the maximum speed at the stroke you desire.
 - (2) Since the ERC2 series use a pulse motor, the load capacity decreases at high speeds. Check in the Speed vs. Load Capacity graph to see if your desired speed and load capacity are supported.
 - (3) The load capacity is based on operation at an acceleration of 0.3G (0.2G for the 4mm-lead model, or when used vertically). This is the upper limit of the acceleration.
 - (4) The value for the horizontal load capacity is with an external guide.
 - (5) See page A-71 for details on push motion.

Speed vs. Load Capacity

Due to the characteristics of the pulse motor, the ERC2 series' load capacity decreases at high speeds. In the table below, check if your desired speed and load capacity are supported.

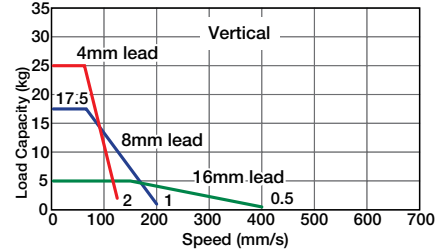
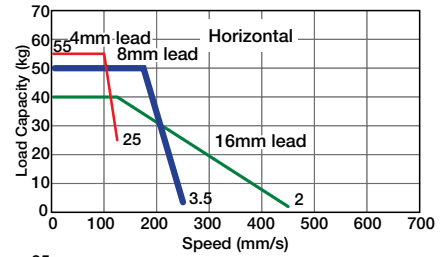

Actuator Specifications

Leads and Payloads

(Note 1) Please note that the maximum load capacity decreases as the speed increases.

Model number	Lead (mm)	Maximum payload (Note 1)		Maximum push force (N)	Stroke (mm)
		Horizontal (kg)	Vertical (kg)		
ERC2-RGD7C-I-PM-16-①-②-③-④	16	~40	~5	220	50 to 300 (every 50mm)
ERC2-RGD7C-I-PM-8-①-②-③-④	8	~50	~17.5	441	
ERC2-RGS7C-I-PM-4-①-②-③-④	4	~55	~25	873	

Stroke and Maximum Speed

Stroke Lead	50~300 (every 50mm)
16	450 <400>
8	250 <200>
4	125

Code explanation ① Stroke ② I/O type ③ Cable length ④ Options *See page A-71 for details on push motion.

(Unit: mm/s)

① Stroke

Stroke (mm)	Standard price
50	—
100	—
150	—
200	—
250	—
300	—

③ Cable Length

Type	Cable symbol	Standard price
Standard type	P (1m)	—
	S (3m)	—
	M (5m)	—
Special length	X06 (6m) ~ X10 (3m)	—
Double ended	W01 (1m) ~ W03 (5m)	—
	W04 (4m) ~ W05 (10m)	—
	W06 (6m) ~ W10 (10m)	—
Robot cable	R01 (1m) ~ R03 (3m)	—
	R04 (4m) ~ R05 (5m)	—
	R06 (6m) ~ R10 (10m)	—
Double ended Robot cable	RW01 (1m) ~ RW03 (3m)	—
	RW04 (4m) ~ RW05 (5m)	—
	RW06 (6m) ~ RW10 (10m)	—

The values in <> apply to the SE type.
* See page 606 for cables for maintenance.

④ Options

Name	Option code	Page	Standard Price
Brake	B	→ A-42	—
Foot bracket	FT	→ A-47	—
Non-motor end specification	NM	→ A-52	—

Actuator Specifications

Item	Description
Drive method	Ball screw, ø12mm, rolled C10
Positioning repeatability	±0.02mm
Lost motion	0.1mm or less
Rod diameter	ø30mm special SUS type
Rod non-rotation precision	±0.05 deg
Ambient operating temperature/humidity	0 to 40°C, 85% RH max. (Non-condensing)

Dimensional Drawings

CAD drawings can be downloaded from the website. www.intelligentactuator.com

For Special Orders Appendix P.15

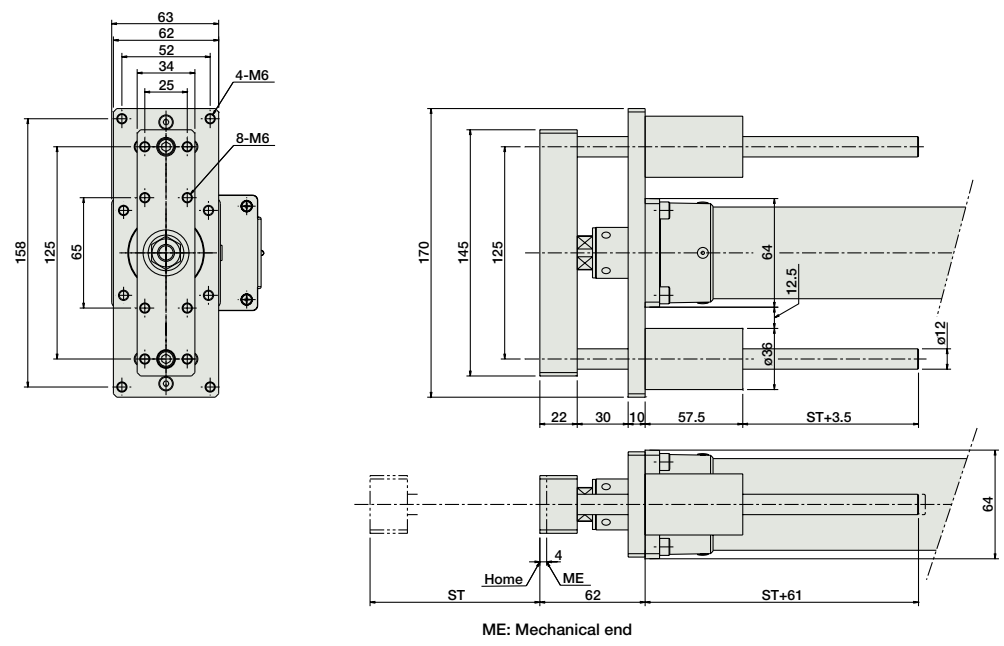

* See page 186 for the dimensions of the actuator.

■ Dimensions and Mass by Stroke

Stroke	50	100	150	200	250	300
Guide weight (kg)	0.5	0.6	0.7	0.8	0.9	1.0
Guide + actuator weight (kg)	3.2	3.5	3.7	4.0	4.2	4.5

I/O type (Controller built into the Actuator)

② I/O type

With the ERC2 series, one of the following three types of built-in controllers can be selected depending on the external input/output (I/O) type. Select the type that meets your purpose.

Name	External view	Model number	Features	Maximum number of positioning points	Input power	Power supply capacity	Standard price	Reference page
PIO Type (NPN Specification)		ERC2-RGD7C-I-PM-□-□-NP-□-□	Simple control type with up to 16-point positioning	16	DC24V	2A max.	—	→ P597
PIO Type (PNP Specification)		ERC2-RGD7C-I-PM-□-□-PN-□-□	Supports the PNP I/O commonly used overseas.	16				
SIO Type		ERC2-RGD7C-I-PM-□-□-SE-□-□	Field Network Connection Serial (Gateway unit used)	64				

- Slider Type
- Mini
- Standard
- Controllers Integrated
- Rod Type
- Mini
- Standard
- Controllers Integrated
- Table/ Arm/ Flat Type
- Mini
- Standard
- Gripper/ Rotary Type
- Linear Servo Type
- Clean-room Type
- Splash-Proof Type
- Pulse Motor
- Servo Motor (24V)
- Servo Motor (200V)
- Linear Servo Motor