

RCP4-RA5C

ROBO Cylinder, Rod Type, Motor Unit Coupled, Actuator Width 52mm, 24-V Pulse Motor

Model Specification Items	RCP4	RA5C	I	<input type="checkbox"/>	<input type="checkbox"/>	<input type="checkbox"/>	P3	<input type="checkbox"/>	<input type="checkbox"/>
	Series	Type	Encoder type	Motor type	Lead	Stroke	Applicable controller	Cable length	Options
			I: Incremental	42P: Pulse motor, size 42□ 42SP: High-thrust pulse motor size 42□	20: 20mm 12: 12mm 6: 6mm 3: 3mm	50: 50mm 400: 400mm (50mm pitch increments)	P3: PCON-CA MSEP-C	N: None P: 1m S: 3m M: 5m X□□: Custom length R□□: Robot cable	See Options below. * If the high-thrust pulse motor is selected, the actuator comes standard with option B (Brake).

* See page Pre-47 for details on the model descriptions.

Built-in guide mechanism

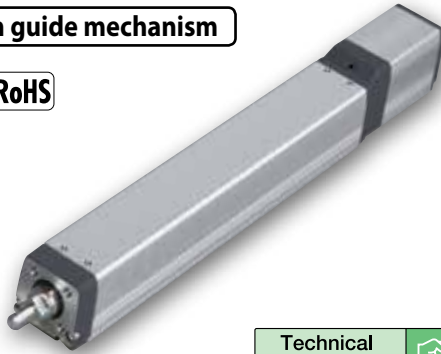

Technical References Appendix P.5



- (1) The maximum payload is the value when operated at 0.3G (0.2G with some models) acceleration. The upper limit of acceleration is 1G (*). Note that raising the acceleration causes the payload to drop. (*): The specific value varies depending on the connected controller and actuator lead. For details, refer to "Selection References" on page A-101 and A-103.
- (2) Take note that the maximum payload and maximum speed vary depending on the controller connected to the RCP4. (Refer to the actuator specifications below.)
- (3) All horizontal payloads are values when an external guide is used.
- (4) See page A-71 for details on push motion.

Correlation Diagrams of Speed and Payload

* The values of the horizontal specification assume that an external guide is used.

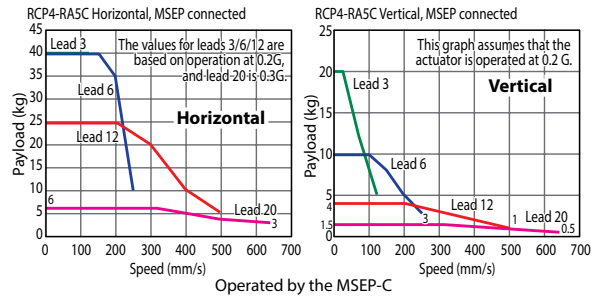
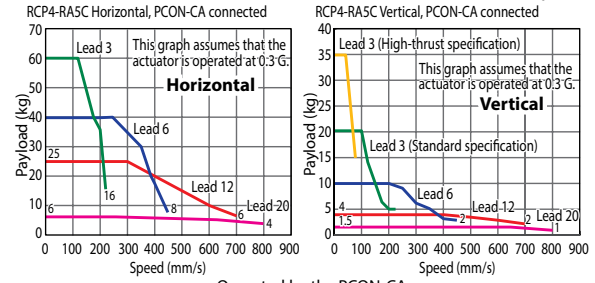

Actuator Specifications

Leads and Payloads

(*) When operated at 0.2 G

Model number	Lead (mm)	Connected controller	Maximum payload		Max. push force (N)	Stroke (mm)
			Horizontal (kg)	Vertical (kg)		
Standard specification	20	PCON-CA	6	1.5	56	50 to 400 (every 50mm)
		MSEP-C	6	1.5 (*)		
	12	PCON-CA	25	4	93	
		MSEP-C	25 (*)	4 (*)		
6	PCON-CA	40	10	185		
	MSEP-C	40 (*)	10 (*)			
3	PCON-CA	60	20	370		
	MSEP-C	40 (*)	10 (*)			
High-thrust specification	3	PCON-CA	—	35	750	

Stroke and Maximum Speed

Lead (mm)	Connected controller	Stroke (mm)	50~400 (every 50mm)
			Maximum speed (mm/s)
20	PCON-CA	800	
	MSEP-C	640	
12	PCON-CA	700	
	MSEP-C	500	
6	PCON-CA	450	
	MSEP-C	250	
3 (Standard)	PCON-CA	225	
	MSEP-C	125	
3 (High-thrust)	PCON-CA	80	

Code explanation ① Stroke ② Cable length ③ Options *See page A-71 for details on push motion.

(Unit: mm/s)

① Stroke

Stroke (mm)	Standard price	
	Standard	High-thrust
50	—	—
100	—	—
150	—	—
200	—	—
250	—	—
300	—	—
350	—	—
400	—	—

② Cable Length

Type	Cable symbol	Standard price
Standard type	P (1m)	—
	S (3m)	—
	M (5m)	—
Special length	X06 (6m) ~ X10 (10m)	—
	X11 (11m) ~ X15 (15m)	—
	X16 (16m) ~ X20 (20m)	—
	R01 (1m) ~ R03 (3m)	—
Robot cable	R04 (4m) ~ R05 (5m)	—
	R06 (6m) ~ R10 (10m)	—
	R11 (11m) ~ R15 (15m)	—
	R16 (16m) ~ R20 (20m)	—
	—	—

* See page A-59 for cables for maintenance.

③ Options

Name	Option code	Page	Standard Price
Brake	B	→ A-42	—
Optional cable exit direction (top)	CJT	→ A-42	—
Optional cable exit direction (right)	CJR	→ A-42	—
Optional cable exit direction (left)	CJL	→ A-42	—
Optional cable exit direction (bottom)	CJB	→ A-42	—
Flange bracket	FL	→ A-44	—
Non-motor end specification	NM	→ A-52	—
Scraper	SC	→ A-55	—

Actuator Specifications

Item	Description
Drive method	Ball screw, ø10mm, rolled C10
Positioning repeatability (*1)	±0.02mm [±0.03mm]
Lost motion	0.1mm or less
Rod	ø22mm stainless steel pipe
Rod non-rotation precision	±0 deg
Allowable rod load mass	Refer to page 148 and page A-117
Rod tip overhang distance	100mm or less
Ambient operating temperature/humidity	0 to 40°C, 85% RH max. (Non-condensing)

(*1) The value at lead 20 is shown in [].

Dimensional Drawings

CAD drawings can be downloaded from the website. www.intelligentactuator.com



- (*1) Connect the motor-encoder integrated cable here.
 - (*2) During home return, be careful to avoid interference from peripheral objects because the slider travels until the mechanical end. Also, please note that the lengths between Home and ME, SE and ME are 2mm for the high-thrust specification.
 - (*3) The orientation of the bolt varies depending on the product.
 - (*4) If the actuator is installed using the front housing and flange, make sure the actuator will not receive any external force.
- ME : Mechanical end
SE : Stroke end

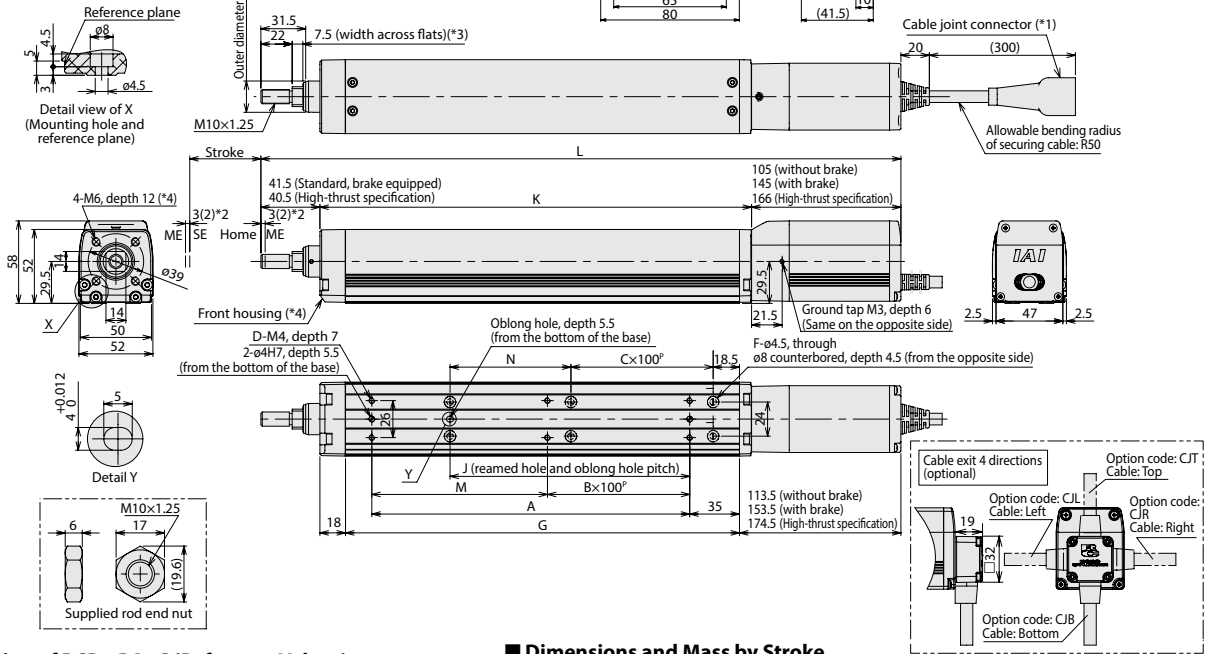

■ Rod Deflection of RCP4-RA5C (Reference Values)

(The graph below plots deflection as measured by installing the actuator vertically and applying a force to the rod from one side.)

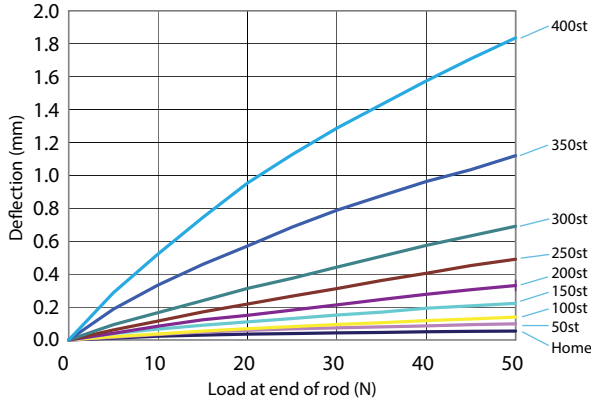

■ Dimensions and Mass by Stroke

Stroke	50	100	150	200	250	300	350	400	
L	Without brake	300	350	400	450	500	550	600	650
	With brake	340	390	440	490	540	590	640	690
	High-thrust specification	360	410	460	510	560	610	660	710
A	73.5	123.5	173.5	223.5	273.5	323.5	373.5	423.5	
B	0	0	1	1	2	2	3	3	
C	0	0	0	1	1	2	2	3	
D	4	4	6	6	8	8	10	10	
F	4	4	4	6	6	8	8	10	
G	127	177	227	277	327	377	427	477	
J	18.5	68.5	118.5	168.5	218.5	268.5	318.5	368.5	
K	153.5	203.5	253.5	303.5	353.5	403.5	453.5	503.5	
M	73.5	123.5	73.5	123.5	73.5	123.5	73.5	123.5	
N	35	85	135	85	135	85	135	85	
Allowable static load at end of rod (N)	65.6	51.2	41.7	34.9	29.8	25.7	22.4	19.7	
Allowable dynamic load at end of rod (N)	Load offset 0mm	32.4	23.6	18.1	14.4	11.6	9.5	7.7	6.2
	Load offset 100mm	25.6	19.7	15.7	12.7	10.4	8.6	7.1	5.7
Allowable static torque at end of rod (N-m)	6.6	5.2	4.3	3.7	3.2	2.8	2.6	2.3	
Allowable dynamic torque at end of rod (N-m)	2.6	2.0	1.6	1.3	1.0	0.9	0.7	0.6	
Weight (kg)	Without brake	1.9	2.1	2.4	2.7	2.9	3.2	3.4	3.7
	With brake	2.1	2.4	2.6	2.9	3.1	3.4	3.7	3.9

Applicable Controllers

RCP4 series actuators can be operated with the controllers indicated below. Select the type according to your intended application.

Name	External view	Model number	Features	Maximum number of positioning points	Input power	Power supply capacity	Standard price	Reference page
Positioner type High-output specification		PCON-CA-42○H-○-2-0	Equipped with a high-output driver PIO control supported	512 points	DC24V	Refer to P618	—	→ P607
Pulse-train type High-output specification		PCON-CA-42○H-PL□-2-0	Equipped with a high-output driver Pulse-train input supported	—				
Field network type High-output specification		PCON-CA-42○H-○-0-0	Equipped with a high-output driver Field network supported	768 points				
Solenoid valve multi-axis type PIO specification		MSEP-C-○-○-○-2-0	Positioner type based on PIO control, allowing up to 8 axes to be connected	3 points	Refer to P572	—	—	→ P563
Solenoid valve multi-axis type Network specification		MSEP-C-○-○-○-0-0	Field network-ready positioner type, allowing up to 8 axes to be connected	256 points				

* ○ indicates I/O type (NP/PN). * ◎ indicates number of axes (1 to 8). * ◎ indicates field network specification symbol. * □ indicates N (NPN specification) or P (PNP specification) symbol. * ○ indicates P (Standard specification) or SP (High-thrust specification) symbol.