

# RCS3-SA8R

ROBO Cylinder, Slider Type, Actuator Width 80mm, 200-V Servo Motor, Aluminum Base, Side-mounted Motor

# RCS3P-SA8R

ROBO Cylinder, Slider Type, Actuator Width 80mm, 200-V Servo Motor, Aluminum Base, Side-mounted Motor **High-precision specification**

Model Specification Items	Series	Type	Encoder type	Motor type	Lead	Stroke	Applicable controller	Cable length	Options
	RCS3: Standard specification RCS3P: High-precision specification	SA8R	I: Incremental A: Absolute	100: Servo motor, 100W 150: Servo motor, 150W	30: 30mm 20: 20mm 10: 10mm 5: 5mm	50: 50mm ? 1100: 1100mm (50mm pitch increments)	T1: XSEL-J/K T2: SCON MSCON SSEL XSEL-P/Q XSEL-R/S	N: None P: 1m S: 3m M: 5m X□□: Custom length R□□: Robot cable	See Options below. *Be sure to specify a code indicating your desired cable exit direction.

\* See page Pre-47 for details on the model descriptions.



\*CE compliance is optional.



Technical References Appendix P.5



- (1) When the stroke is increased, the maximum speed will drop to prevent reaching dangerous speeds of ball screws. Confirm the maximum speed at the desired stroke by referring to the table of strokes and maximum speeds below.
- (2) The payload represents a value when the actuator is operated at a horizontal acceleration of 0.3 G (lead 5: 0.2 G) and vertical acceleration of 0.2 G.
- (3) The payload drops when the acceleration is raised. For details, refer to the list of payloads by acceleration provided on page A-108.
- (4) See page A-71 for details on push motion.

### Actuator Specifications

#### Leads and Payloads

Model number	Motor output (W)	Lead (mm)	Maximum payload		Rated thrust (N)	Stroke (mm)
			Horizontal (kg)	Vertical (kg)		
RCS3[RCS3P]-SA8R-①-100-30-②-③-④-⑤	100	30	8	2	56.6	50 to 1100 (every 50mm)
RCS3[RCS3P]-SA8R-①-100-20-②-③-④-⑥		20	20	4	84.9	
RCS3[RCS3P]-SA8R-①-100-10-②-③-④-⑤		10	40	8	169.8	
RCS3[RCS3P]-SA8R-①-100-5-②-③-④-⑤		5	80	16	339.7	
RCS3[RCS3P]-SA8R-①-150-30-②-③-④-⑥	150	30	12	3	85.1	
RCS3[RCS3P]-SA8R-①-150-20-②-③-④-⑥		20	30	6	127.6	
RCS3[RCS3P]-SA8R-①-150-10-②-③-④-⑤		10	60	12	255.3	

#### Stroke and Maximum Speed

Stroke Lead	50 to 650 (every 50mm)									
	700	750	800	850	900	950	1000	1050	1100	
30	1800	1610	1420	1260	1120	1010	910	830	760	690
20	1200	1070	940	840	750	670	610	550	500	460
10	600	530	470	410	370	340	310	270	250	230
5	300	260	230	200	180	170	150	135	120	110

(Unit: mm/s)

Code explanation ① Encoder type ② Stroke ③ Applicable Controller ④ Cable length ⑤ Options \*See page A-71 for details on push motion.

#### ① Encoder Type / ② Stroke

② Stroke (mm)	Standard Prices							
	RCS3-SA8R				RCS3P-SA8R			
	① Encoder Type				① Encoder Type			
	Incremental		Absolute		Incremental		Absolute	
	Motor wattage	Motor wattage	Motor wattage	Motor wattage	Motor wattage	Motor wattage	Motor wattage	Motor wattage
	100W	150W	100W	150W	100W	150W	100W	150W
50/100	—	—	—	—	—	—	—	—
150/200	—	—	—	—	—	—	—	—
250/300	—	—	—	—	—	—	—	—
350/400	—	—	—	—	—	—	—	—
450/500	—	—	—	—	—	—	—	—
550/600	—	—	—	—	—	—	—	—
650/700	—	—	—	—	—	—	—	—
750/800	—	—	—	—	—	—	—	—
850/900	—	—	—	—	—	—	—	—
950/1000	—	—	—	—	—	—	—	—
1050/1100	—	—	—	—	—	—	—	—

#### ④ Cable Length

Type	Cable symbol	Standard price
Standard type	P (1m)	—
	S (3m)	—
	M (5m)	—
Special length	X06 (6m) ~ X10 (10m)	—
	X11 (11m) ~ X15 (15m)	—
	X16 (16m) ~ X20 (20m)	—
Robot cable	R01 (1m) ~ R03 (3m)	—
	R04 (4m) ~ R05 (5m)	—
	R06 (6m) ~ R10 (10m)	—
	R11 (11m) ~ R15 (15m)	—
	R16 (16m) ~ R20 (20m)	—

\* See page A-59 for cables for maintenance.

#### ⑤ Options

Name	Option code	Page	Standard Price
Brake	B	→ A-42	—
CE compliance	CE	→ A-42	—
Motor mounted on left, cables exit from back	MLE	→ A-52	—
Motor mounted on left, cables exit from side	MLS	→ A-52	—
Motor mounted on right, cables exit from back	MRE	→ A-52	—
Motor mounted on right, cables exit from side	MRS	→ A-52	—
Non-motor end specification	NM	→ A-52	—

#### Actuator Specifications RCS3P specifications are shown in []. (Other items are the same.)

Item	Description
Drive method	Ball screw, ø16mm, rolled C10 [rolled C5]
Positioning repeatability	±0.02mm [±0.01mm]
Lost motion	0.1mm [0.05mm] or less
Base	Material: Aluminum, white alumite treatment
Allowable static moment	Ma: 113.5 N·m, Mb: 117 N·m, Mc: 266 N·m
Allowable dynamic moment (*)	Ma: 23.1 N·m, Mb: 32.9 N·m, Mc: 54.1 N·m
Overhang load length	390mm max. in Ma direction, 390mm max. in Mb/Mc directions
Ambient operating temperature/humidity	0 to 40°C, 85% RH max. (Non-condensing)

(\*) When the traveling life is assumed as 10,000km.  
Direction of allowable load moment.

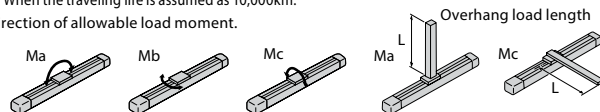

Dimensional Drawings

CAD drawings can be downloaded from the website.

www.intelligentactuator.com

For Special Orders

Appendix P.15



- (\*1) Connect the motor and encoder cables here. See page A-59 for details on cables.
- (\*2) After homing, the slider moves to the ME, therefore, please watch for any interference with surrounding objects.

ME : Mechanical end  
SE : Stroke end

\*Offset reference position for Ma moment is same as that of SA8C type.  
(Refer to page 112.)

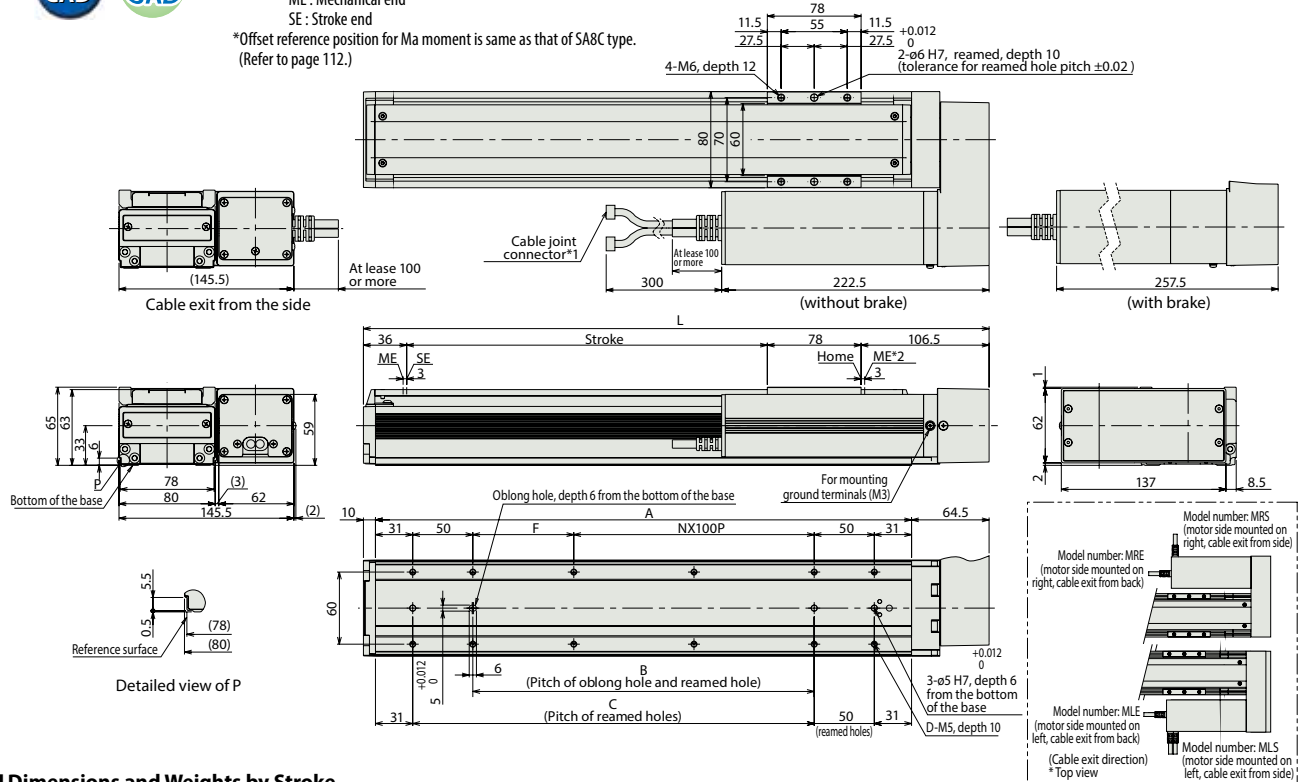

■ Dimensions and Weights by Stroke

Stroke	50	100	150	200	250	300	350	400	450	500	550	600	650	700	750	800	850	900	950	1000	1050	1100		
L	270.5	320.5	370.5	420.5	470.5	520.5	570.5	620.5	670.5	720.5	770.5	820.5	870.5	920.5	970.5	1020.5	1070.5	1120.5	1170.5	1220.5	1270.5	1320.5		
A	196	246	296	346	396	446	496	546	596	646	696	746	796	846	896	946	996	1046	1096	1146	1196	1246		
B	34	84	134	184	234	284	334	384	434	484	534	584	634	684	734	784	834	884	934	984	1034	1084		
C	84	134	184	234	284	334	384	434	484	534	584	634	684	734	784	834	884	934	984	1034	1084	1134		
D	8	8	10	10	12	12	14	14	16	16	18	18	20	20	22	22	24	24	26	26	28	28		
F	34	84	34	84	34	84	34	84	34	84	34	84	34	84	34	84	34	84	34	84	34	84		
N	0	0	1	1	2	2	3	3	4	4	5	5	6	6	7	7	8	8	9	9	10	10		
Weight (kg)	100W	without brake	3.6	3.9	4.2	4.5	4.8	5.1	5.4	5.7	6.0	6.3	6.6	6.9	7.2	7.5	7.8	8.1	8.4	8.7	9.0	9.3	9.6	9.9
		with brake	4.0	4.3	4.6	4.9	5.2	5.5	5.8	6.1	6.4	6.7	7.0	7.3	7.6	7.9	8.2	8.5	8.8	9.1	9.4	9.7	10.0	10.3
	150W	without brake	3.8	4.1	4.4	4.7	5.0	5.3	5.6	5.9	6.2	6.5	6.8	7.1	7.4	7.7	8.0	8.3	8.6	8.9	9.2	9.5	9.8	10.1
		with brake	4.1	4.4	4.7	5.0	5.3	5.6	5.9	6.2	6.5	6.8	7.1	7.4	7.7	8.0	8.3	8.6	8.9	9.2	9.5	9.8	10.1	10.4

③ Applicable Controllers

RCS3-series actuators can be operated with the following controllers. Select an appropriate controller type according to your application.

Name	External view	Model number	Features	Maximum number of positioning points	Input power	Power supply capacity	Standard price	Reference page
Positioner mode		SCON-CA-100①-NP-2-② SCON-CA-150①-NP-2-②	Up to 512 positioning points are supported.	512 points	Single-phase 100VAC  Single-phase 200VAC  3-phase 200VAC (XSEL-P/Q/R/S ONLY)	388 VA max.  * 1-axis specification operated at 150W	—	→ P643
Solenoid valve mode			Actuators can be operated through the same control used for solenoid valves.	7 points				
Field network type			Movement by numerical specification is supported.	768 points				
Pulse-train input control type			Dedicated pulse-train input type	(—)				
Positioner multi-axis, network type		MSCON-C-1-100①-④-V-0-② MSCON-C-1-150①-④-V-0-②	Up to 6 axes can be operated. Movement by numerical specification is supported.	256 points			—	→ P655
Program control type, 1 to 2 axes		SSEL-CS-1-100①-NP-2-② SSEL-CS-1-150①-NP-2-②	Program operation is supported. Up to 2 axes can be operated.	20,000 points			—	→ P685
Program control type, 1 to 8 axes		XSEL-③-1-100①-N1-EEE-2-④ XSEL-③-1-150①-N1-EEE-2-④	Program operation is supported. Up to 8 axes can be operated.	Varies depending on the number of axes connected			—	→ P695

\* This is for the single-axis MSCON, SSEL, and XSEL.  
 \* ① indicates the power-supply voltage type (1: 100V / 2: Single-phase 200V).  
 \* ② indicates the power-supply voltage type (1: 100V / 2: Single-phase 200V / 3: Three-phase 200V).  
 \* ③ indicates the encoder type (I: Incremental / A: Absolute).  
 \* ④ indicates the XSEL type (J / K / P / Q / R / S).  
 \* ⑤ indicates field network specification symbol.

Slider Type

Mini

Standard

Controllers Integrated

Rod Type

Mini

Standard

Controllers Integrated

Table/ Arm/ Flat Type

Mini

Standard

Gripper/ Rotary Type

Linear Servo Type

Clean-room Type

Splash-Proof Type

Pulse Motor

Servo Motor (24V)

Servo Motor (200V)

Linear Servo Motor