

RCP6(S)-WSA12R

±10μm Standard
Simple Dust-proof
Battery-less Absolute
Motor Unit Type
Side-mounted Motor
Body Width 120* mm
24v Stepper Motor

Model Specification Items	Series	Type	Encoder Type	Motor Type	Lead	Stroke	Applicable Controller/I/O Type	Cable Length	Options
	RCP6: Separate Controller RCP6S: Built-in Controller	WSA12R	WA	42P	20: 20mm 12: 12mm 6: 6mm 3: 3mm	50: 50mm 12: 12mm 6: 6mm 3: 3mm	[RCP6] P3: PCON MCON MSEL [RCP6S] SE: SIO Type	N : None P : 1m S : 3m M : 5m X□□ : Specified Length R□□ : Robot Cable	* Body width does not include the width of the side-mounted motor. Please refer to the options table below. * Please make sure to specify either ML or MR when ordering the side-mounted motor type.

* RCP6 does not include a controller. RCP6S includes a built-in controller.
* Please refer to P.10 for more information about the model specification items.

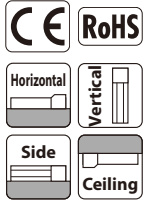

* Depending on the model, there may be some limitations to using the vertical, side, and ceiling mount positions. Please contact IAI for more information regarding mounting positions.

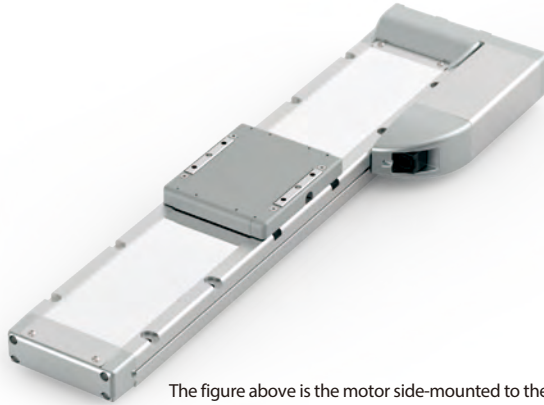

The figure above is the motor side-mounted to the left (ML).

POINT Selection Notes

- (1) The maximum acceleration/deceleration is 1G for horizontal, and 0.5G for vertical use.
- (2) The actuator specification displays the payload's maximum value, but it will vary depending on the acceleration and speed. Please refer to the "Selection Guidelines" (RCP6 Tables of Payload by Speed/Acceleration) on P.115 for more details.
- (3) When performing push-motion operation, please confirm the push force of each model by checking the "Correlation diagram of push force and current limit" on P.113.
- (4) Depending on the ambient operational temperature, duty control is necessary for the RCP6S (built-in controller type) with lead 3/6. Please refer to P.130 for more information.

Correlation Diagrams of Speed and Payload

High-output enabled with PCON/MCON/MSEL connected.
RCP6(S)-WSA12R Horizontal mount

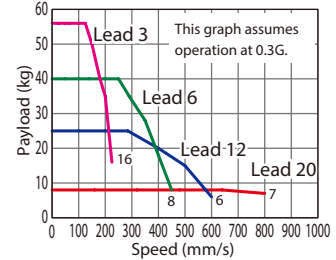

RCP6(S)-WSA12R Vertical mount

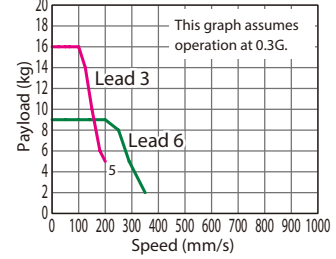

Actuator Specifications

Lead and Payload

Model Number	Lead (mm)	Connected Controller	Max. Payload		Stroke (mm)
			Horizontal (kg)	Vertical (kg)	
RCP6(S)-WSA12R-WA-42P-20-①-②-③-④	20	High-output Enabled	12	-	50~800 (The increment of stroke is 50mm)
RCP6(S)-WSA12R-WA-42P-12-①-②-③-④	12	High-output Enabled	25	-	
RCP6(S)-WSA12R-WA-42P-6-①-②-③-④	6	High-output Enabled	40	9	
RCP6(S)-WSA12R-WA-42P-3-①-②-③-④	3	High-output Enabled	60	16	

Legend: ① Stroke ② Applicable controller/I/O type ③ Cable length ④ Options

Stroke and Max. Speed

(Unit: mm/s)

Lead (mm)	Connected Controller	Max. Speed (mm/s)								
		50~350 (Every 50mm)	400 (mm)	450 (mm)	500 (mm)	550 (mm)	600 (mm)	650 (mm)	750 (mm)	800 (mm)
20	High-output Enabled	800				740	650	580	520	
12	High-output Enabled	600		535	465	405	355	315	285	
6	High-output Enabled	450 <400>	435 <400>	365	310	265	230	200	175	140
3	High-output Enabled	225	215	180	150	130	115	100	85	70

Values in brackets < > are for vertical use.

① Stroke

Stroke (mm)	RCP6	RCP6S	Stroke (mm)	RCP6	RCP6S
50	○	○	450	○	○
100	○	○	500	○	○
150	○	○	550	○	○
200	○	○	600	○	○
250	○	○	650	○	○
300	○	○	700	○	○
350	○	○	750	○	○
400	○	○	800	○	○

③ Cable Length

Cable Type	Cable Code	RCP6	RCP6S
Standard	P (1m)	○	○
	S (3m)	○	○
	M (5m)	○	○
Specified Length	X06 (6m) ~X10 (10m)	○	○
	X11 (11m) ~X15 (15m)	○	○
	X16 (16m) ~X20 (20m)	○	○
	R01 (1m) ~R03 (3m)	○	○
Robot Cable	R04 (4m) ~R05 (5m)	○	○
	R06 (6m) ~R10 (10m)	○	○
	R11 (11m) ~R15 (15m)	○	○
	R16 (16m) ~R20 (20m)	○	○

* Please refer to P.144 for more information regarding the maintenance cables.

④ Options

Name	Option Code	Reference Page
Brake	B	See P.105
Cable exit direction (Outside)	CJO	See P.105
Motor side-mounted to the left	ML	See P.109
Motor side-mounted to the right	MR	See P.109
Non-motor end specification	NM	See P.110

When selecting multiple options, please list them in alphabetical order. (e.g. B-CJB-NM)

Actuator Specifications

Item	Description
Drive system	Ball screw φ10mm, rolled C10
Positioning repeatability	±0.01mm
Lost motion	0.1mm or less
Base	Material: Aluminum with white alumite treatment
Static allowable moment	Ma: 311N·m, Mb: 311N·m, Mc: 827N·m
Dynamic allowable moment (*1)	Ma: 87.5N·m, Mb: 87.5N·m, Mc: 233N·m
Ambient operating temp. & humidity	0~40°C, 85% RH or less (Non-condensing)

* Reference for overhang load length: Ma: 450mm or less, Mb, Mc: 450mm or less

(*1) Assumes a standard rated life of 5,000km. The service life will vary depending on operation and installation conditions.

Please refer to our website for more information regarding the directions of the allowable moment and overhang load length.

Dimensions

CAD drawings can be downloaded from our website.
www.intelligentactuator.com



*1 When the slider is returning to its home position, please be careful of interference from surrounding objects, as it will travel until it reaches the M.E.
M.E: Mechanical end S.E: Stroke end

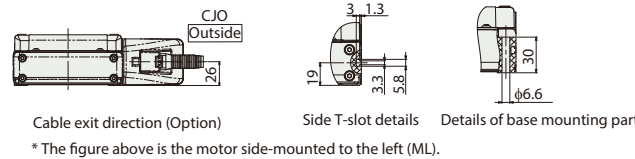
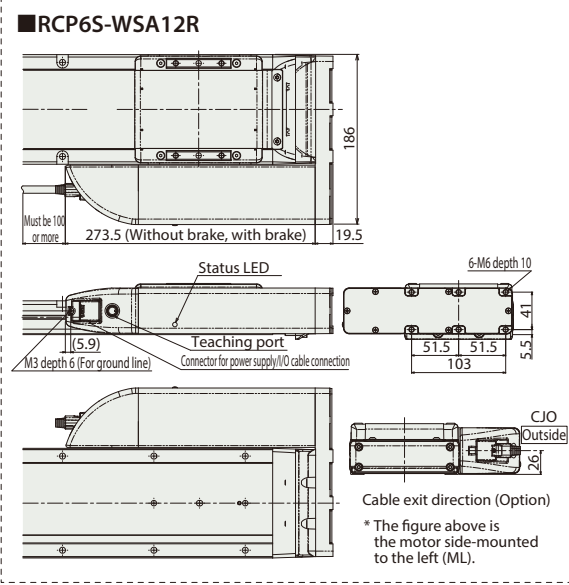
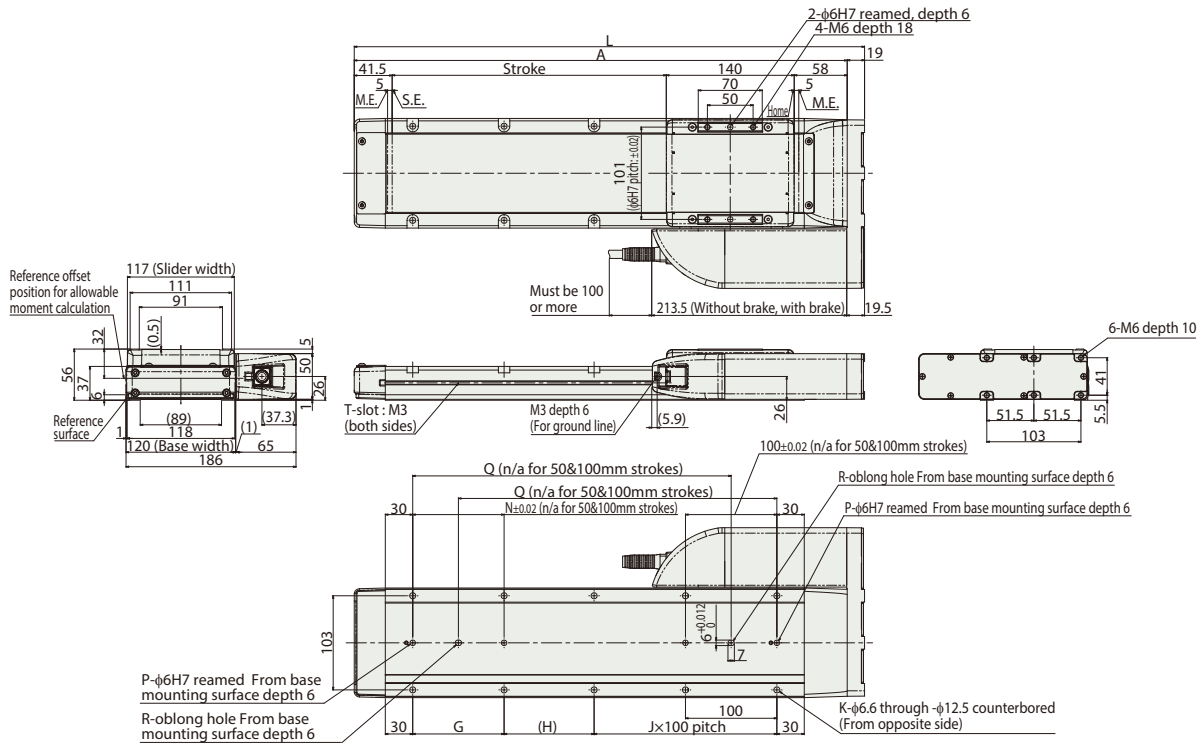

Dimensions and Mass by Stroke

Stroke	50	100	150	200	250	300	350	400	450	500	550	600	650	700	750	800
L	308.5	358.5	408.5	458.5	508.5	558.5	608.5	658.5	708.5	758.5	808.5	858.5	908.5	958.5	1,008.5	1,058.5
A	289.5	339.5	389.5	439.5	489.5	539.5	589.5	639.5	689.5	739.5	789.5	839.5	889.5	939.5	989.5	1,039.5
G			100	100	100	100	100	100	100	100	100	100	100	100	100	100
H	148.5	198.5	248.5	298.5	348.5	398.5	448.5	498.5	548.5	598.5	648.5	698.5	748.5	798.5	848.5	898.5
J	0	0	1	1	2	2	3	3	4	4	5	5	6	6	7	7
K	4	4	8	8	10	10	12	12	14	14	16	16	18	18	20	20
N	-	-	100	100	100	100	100	100	100	100	100	100	100	100	100	100
P	1	1	2	2	2	2	2	2	2	2	2	2	2	2	2	2
Q	-	-	198.5	248.5	298.5	348.5	398.5	448.5	498.5	548.5	598.5	648.5	698.5	748.5	798.5	848.5
R	0	0	1	1	1	1	1	1	1	1	1	1	1	1	1	1
Mass (kg)	RCP6 w/o brake	4.1	4.4	4.7	5.1	5.4	5.7	6.1	6.4	6.7	7.1	7.4	7.7	8.1	8.4	8.7
	RCP6 w/ brake	4.1	4.5	4.8	5.1	5.5	5.8	6.1	6.5	6.8	7.1	7.5	7.8	8.1	8.5	8.8
RCP6S	w/o brake	4.2	4.5	4.9	5.2	5.5	5.9	6.2	6.5	6.9	7.2	7.5	7.9	8.2	8.5	8.9
	w/ brake	4.3	4.6	4.9	5.3	5.6	5.9	6.3	6.6	6.9	7.3	7.6	7.9	8.3	8.6	8.9

Applicable Controllers

The RCP6 series actuators can be operated by the controllers indicated below. Please select the type depending on your intended use. * Please refer to P.147 for more information about the built-in controller of RCP6S series.

Name	External view	Max. number of controlled axes	Input power	Control method				Maximum number of positioning points	Reference page
				Positioner	Pulse train	Program	Network *Option		
PCON-CB/CGB		1	DC24V	● *Option	● *Option	-	DeviceNet, CC-Link, EtherCAT, EtherNet/IP, CompoNet, MEXATROLINK	512 (768 for network spec.)	Please see P.131
MCON-C/CG		4		This model is network-compatible only.				256	Please see the MCON catalog.
MSEL-PC/PG		4	Single-phase 100~230VAC	-	-	●	Note: The type of compatible networks will vary depending on the controller. Please refer to reference page for more information.	30,000	Please see the MSEL-PC/PG catalog.

* Please select "high-output specification" as an option for the MCON. With the MCON, operation is possible only when the high-output specification is selected.