

RCP6(S)-SA7C

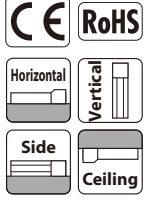

Model Specification Items	Series	Type	Encoder Type	Motor Type	Lead	Stroke	Applicable Controller/I/O Type	Cable Length	Options
	SA7C	WA	56P						
	RCP6: Separate Controller RCP6S: Built-in Controller	WA: Battery-less Absolute	56P: Stepper Motor 56□ Size	24: 24mm 16: 16mm 8: 8mm 4: 4mm	50: 50mm 800: 800mm (50mm increments)	[RCP6] P3: PCON MCON MSEL [RCP6S] SE: SIO Type	N: None P: 1m S: 3m M: 5m X□□: Specified Length R□□: Robot Cable	Please refer to the options table below.	

* RCP6 does not include a controller. RCP6S includes a built-in controller.
* Please refer to P.10 for more information about the model specification items.



*Depending on the model, there may be some limitations to using the vertical, side, and ceiling mount positions. Please contact IAI for more information regarding mounting positions.



- POINT Selection Notes**
- (1) The maximum acceleration/deceleration is 1G for horizontal, and 0.5G for vertical use.
 - (2) The actuator specification displays the payload's maximum value, but it will vary depending on the acceleration and speed. Please refer to the "Selection Guidelines" (RCP6 Tables of Payload by Speed/Acceleration) on P.115 for more details.
 - (3) When performing push-motion operation, please confirm the push force of each model by checking the "Correlation diagram of push force and current limit" on P.113.
 - (4) Depending on the ambient operational temperature, duty control is necessary for the RCP6S (built-in controller type) with lead 4/8/16. Please refer to P.130 for more information.

Correlation Diagrams of Speed and Payload

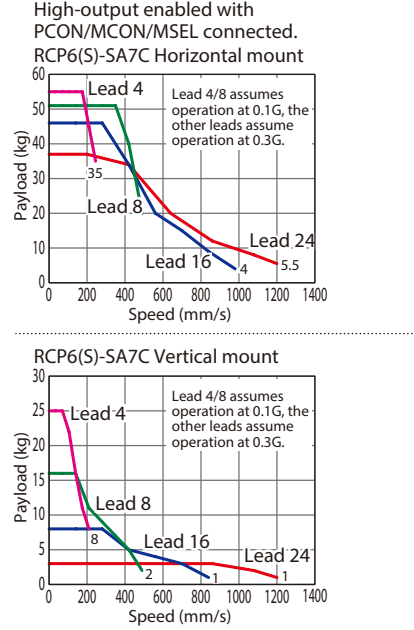

Actuator Specifications

Lead and Payload

Model Number	Lead (mm)	Connected Controller	Max. Payload		Stroke (mm)
			Horizontal (kg)	Vertical (kg)	
RCP6(S)-SA7C-WA-56P-24-①-②-③-④	24	High-output Enabled	37	3	50~800 (The increment of stroke is 50mm)
RCP6(S)-SA7C-WA-56P-16-①-②-③-④	16	High-output Enabled	46	8	
RCP6(S)-SA7C-WA-56P-8-①-②-③-④	8	High-output Enabled	51	16	
RCP6(S)-SA7C-WA-56P-4-①-②-③-④	4	High-output Enabled	55	25	

Stroke and Max. Speed

(Unit: mm/s)

Lead (mm)	Connected Controller	50~500 (Every 50mm)	550 (mm)	600 (mm)	650 (mm)	700 (mm)	750 (mm)	800 (mm)
24	High-output Enabled	1,200	1,095	965	850	760		
16	High-output Enabled	980 <840>	965 <840>	830	720	635	560	500
8	High-output Enabled	490	475	410	355	315	275	245
4	High-output Enabled	245 <210>	235 <210>	205	175	155	135	120

Values in brackets < > are for vertical use.

Legend: ① Stroke ② Applicable controller/I/O type ③ Cable length ④ Options

① Stroke

Stroke (mm)	RCP6	RCP6S	Stroke (mm)	RCP6	RCP6S
50	○	○	450	○	○
100	○	○	500	○	○
150	○	○	550	○	○
200	○	○	600	○	○
250	○	○	650	○	○
300	○	○	700	○	○
350	○	○	750	○	○
400	○	○	800	○	○

③ Cable Length

Cable Type	Cable Code	RCP6	RCP6S
Standard	P (1m)	○	○
	S (3m)	○	○
	M (5m)	○	○
Specified Length	X06 (6m) ~X10 (10m)	○	○
	X11 (11m) ~X15 (15m)	○	○
	X16 (16m) ~X20 (20m)	○	○
	R01 (1m) ~R03 (3m)	○	○
Robot Cable	R04 (4m) ~R05 (5m)	○	○
	R06 (6m) ~R10 (10m)	○	○
	R11 (11m) ~R15 (15m)	○	○
	R16 (16m) ~R20 (20m)	○	○

* Please refer to P.144 for more information regarding the maintenance cables.

④ Options

Name	Option Code	Reference Page
Brake	B	See P.105
Cable exit direction (Top)	CJT	See P.105
Cable exit direction (Right)	CJR	See P.105
Cable exit direction (Left)	CJL	See P.105
Cable exit direction (Bottom)	CJB	See P.105
High-precision specification *	HPR	See P.108
Non-motor end specification	NM	See P.110

* Positioning repeatability is ±5µm for high-precision specification (HPR).
High-precision specification option cannot be selected for lead 16, 24.
When selecting multiple options, please list them in alphabetical order. (e.g. B-CJB-NM)

Actuator Specifications

Item	Description
Drive system	Ball screw φ12mm, rolled C10
Positioning repeatability (*1)	±0.01mm [±0.005mm]
Lost motion	0.1mm or less
Base	Material: Aluminum with white alumite treatment
Static allowable moment	Ma: 115N·m, Mb: 115N·m, Mc: 229N·m
Dynamic allowable moment (*2)	Ma: 44.7N·m, Mb: 44.7N·m, Mc: 89.1N·m
Ambient operating temp. & humidity	0~40°C, 85% RH or less (Non-condensing)

* Reference for overhang load length: Ma: 300mm or less, Mb, Mc: 300mm or less
(*1) Values in [] are for high-precision (for lead 4/8) specification.
(*2) Assumes a standard rated life of 5,000km. The service life will vary depending on operation and installation conditions.
Please refer to our website for more information regarding the directions of the allowable moment and overhang load length.

Dimensions

CAD drawings can be downloaded from our website.
www.intelligentactuator.com



*1 When the slider is returning to its home position, please be careful of interference from surrounding objects, as it will travel until it reaches the M.E.
M.E: Mechanical end S.E: Stroke end

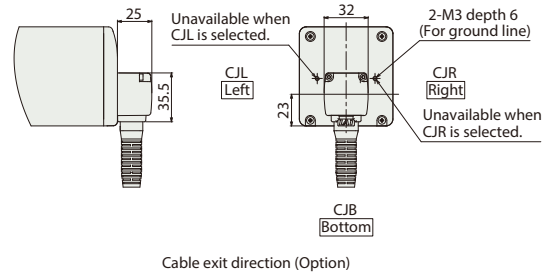
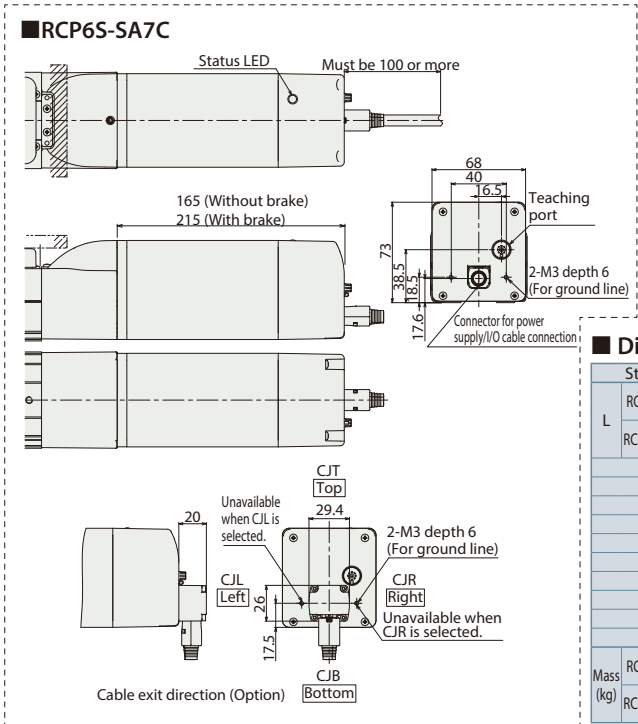
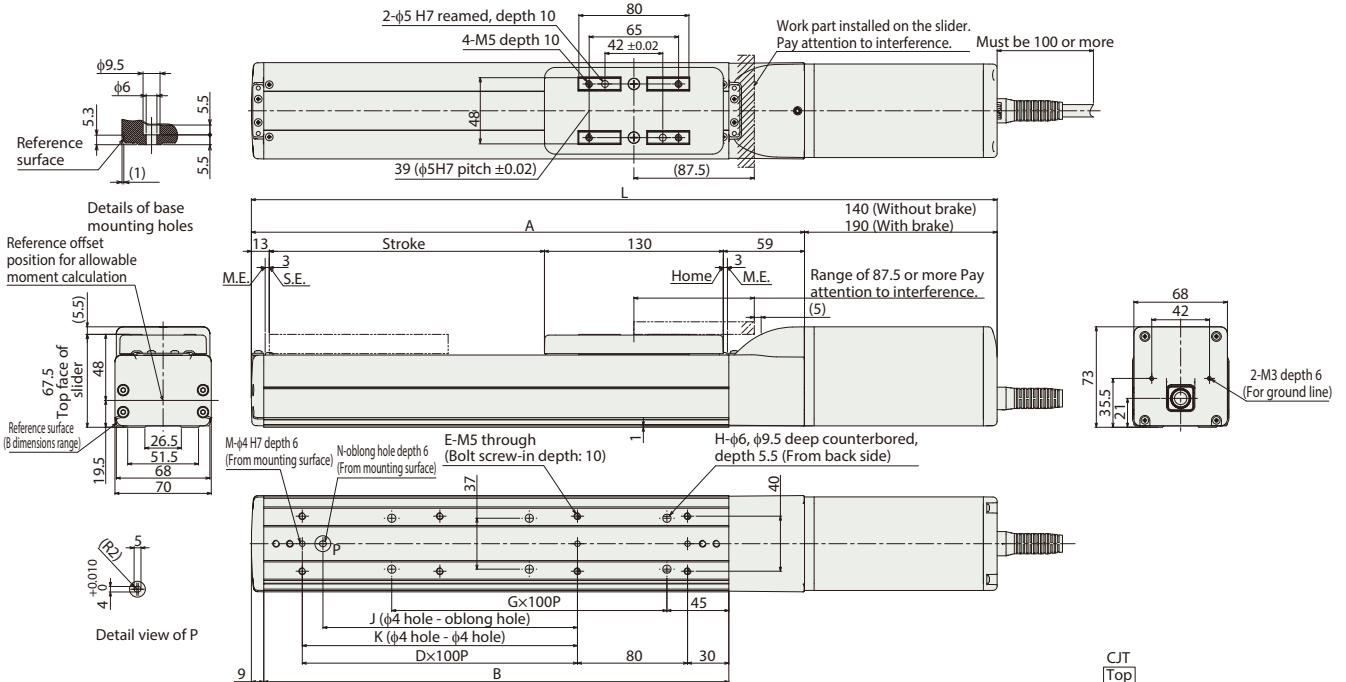

■ Dimensions and Mass by Stroke

	Stroke	50	100	150	200	250	300	350	400	450	500	550	600	650	700	750	800
L	RCP6 w/o brake	392	442	492	542	592	642	692	742	792	842	892	942	992	1,042	1,092	1,142
	RCP6S w/o brake	417	467	517	567	617	667	717	767	817	867	917	967	1,017	1,067	1,117	1,167
A	RCP6 w/ brake	442	492	542	592	642	692	742	792	842	892	942	992	1,042	1,092	1,142	1,192
	RCP6S w/ brake	467	517	567	617	667	717	767	817	867	917	967	1,017	1,067	1,117	1,167	1,217
B		252	302	352	402	452	502	552	602	652	702	752	802	852	902	952	1,002
D		188	238	288	338	388	438	488	538	588	638	688	738	788	838	888	938
E		0	1	1	2	2	3	3	4	4	5	5	6	6	7	7	8
F		4	6	6	8	8	10	10	12	12	14	14	16	16	18	18	20
G		1	1	2	2	3	3	4	4	5	5	6	6	7	7	8	8
H		4	4	6	6	8	8	10	10	12	12	14	14	16	16	18	18
J		0	85	85	185	185	285	285	385	385	485	485	585	585	685	685	785
K		0	0	100	200	200	300	300	400	400	500	500	600	600	700	700	800
M		2	2	3	3	3	3	3	3	3	3	3	3	3	3	3	3
N		0	1	1	1	1	1	1	1	1	1	1	1	1	1	1	1
Mass (kg)	RCP6 w/o brake	3.6	3.8	4.0	4.3	4.5	4.7	4.9	5.2	5.4	5.6	5.9	6.1	6.3	6.5	6.8	7.0
	RCP6S w/o brake	3.8	4.0	4.2	4.4	4.7	4.9	5.1	5.3	5.6	5.8	6.0	6.3	6.5	6.7	7.0	7.2
	RCP6 w/ brake	4.0	4.2	4.5	4.7	4.9	5.1	5.4	5.6	5.8	6.1	6.3	6.5	6.7	7.0	7.2	7.4
	RCP6S w/ brake	4.2	4.4	4.6	4.9	5.1	5.3	5.6	5.8	6.0	6.2	6.5	6.7	6.9	7.1	7.4	7.6

② Applicable Controllers

The RCP6 series actuators can be operated by the controllers indicated below. Please select the type depending on your intended use. * Please refer to P.147 for more information about the built-in controller of RCP6S series.

Name	External view	Max. number of controlled axes	Input power	Control method				Maximum number of positioning points	Reference page
				Positioner	Pulse train	Program	Network *Option		
PCON-CB/CGB		1	DC24V	● *Option	● *Option	-	DeviceNet CC-Link EtherCAT EtherNet/IP CompoNet	512 (768 for network spec.)	Please see P.131
MCON-C/CG		4		This model is network-compatible only.				256	Please see the MCON catalog.
MSEL-PC/PG		4	Single-phase 100~230VAC	-	-	●	Note: The type of compatible networks will vary depending on the controller. Please refer to reference page for more information.	30,000	Please see the MSEL-PC/PG catalog.

* Please select "high-output specification" as an option for the MCON. With the MCON, operation is possible only when the high-output specification is selected.