

# RCP6(S)-RRA8C

Battery-less Absolute
Motor Unit Type
Coupled Motor
Body Width 85 mm
24v Stepper Motor

Model Specification Items	Series	Type	Encoder Type	Motor Type	Lead	Stroke	Applicable Controller/I/O Type	Cable Length	Options
	RCP6: Separate Controller RCP6S: Built-in Controller	<b>RRA8C</b>	<b>WA</b>	<b>60P</b>	20: 20mm 10: 10mm 5: 5mm	50: 50mm 700: 700mm (50mm increments)	[RCP6] P4: PCON- CFB/CGFB [RCP6S] SE: SIO Type	N : None P : 1m S : 3m M : 5m X□ : Specified Length R□ : Robot Cable	Please refer to the options table below.

\* RCP6 does not include a controller. RCP6S includes a built-in controller.  
\* Please refer to P.11 for more information about the model specification items.

## Radial Load OK

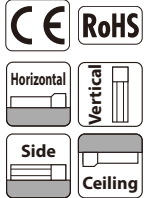

\*Depending on the model, there may be some limitations to using the vertical, side, and ceiling mount positions. Please contact IAI for more information regarding mounting positions.



- (1) The maximum acceleration/deceleration is 0.1G for lead 5 and 0.2G for lead 10/20.
- (2) The actuator specification displays the payload's maximum value, but it will vary depending on the acceleration and speed. Please refer to the "Selection Guidelines" (RCP6 Tables of Payload by Speed/Acceleration) on P.115 for more details.
- (3) The radial cylinder is equipped with a built-in guide. Please refer to the graphs shown in P.127 and after for the allowable load mass.
- (4) When performing push-motion operation, please confirm the push force of each model by checking the "Correlation diagram of push force and current limit" on P.113.
- (5) For RCP6S (built-in controller type), please limit the duty cycle to 70% or less.
- (6) The service life of an actuator varies depending on the payload when using vertically. Please refer to P. 114 for more information.

## Correlation Diagrams of Speed and Payload

PCON connected.

RCP6(S)-RRA8C Horizontal mount

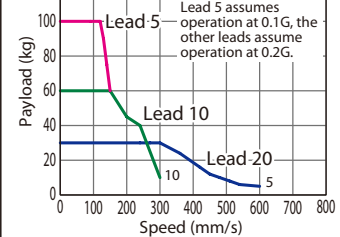

RCP6(S)-RRA8C Vertical mount

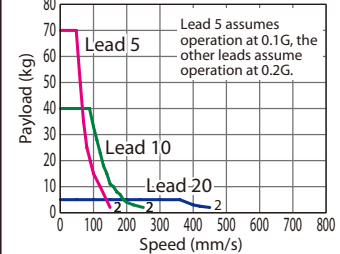

## Actuator Specifications

### Lead and Payload

(Note 1) The payload assumes that there is an external guide.

Model Number	Lead (mm)	Max. Payload (kg) (Note 1)		Stroke (mm)
		Horizontal	Vertical	
RCP6(S)-RRA8C-WA-60P-20-①-②-③-④	20	30	5	50~700 (The increment of stroke is 50mm)
RCP6(S)-RRA8C-WA-60P-10-①-②-③-④	10	60	40	
RCP6(S)-RRA8C-WA-60P-5-①-②-③-④	5	100	70	

Legend: ① Stroke ② Applicable controller/I/O type ③ Cable length ④ Options

### Stroke and Max. Speed

(Unit: mm/s)

Lead (mm)	50 (mm)	100 (mm)	150 (mm)	200 (mm)	250~350 (mm)	400 (mm)	450 (mm)	500 (mm)	550 (mm)	600 (mm)	650 (mm)	700 (mm)
20	280	405	505 <450>	585 <450>	600 <450>	520 <450>	440	360	320	280	240	220
10	280 <250>		300 <250>			260 <250>	220	180	160	140	120	110
5			150			130	110	90	80	70	60	55

Values in brackets < > are for vertical use.

### ① Stroke

Stroke (mm)	RCP6	RCP6S	Stroke (mm)	RCP6	RCP6S
50	○	○	400	○	○
100	○	○	450	○	○
150	○	○	500	○	○
200	○	○	550	○	○
250	○	○	600	○	○
300	○	○	650	○	○
350	○	○	700	○	○

### ④ Options

Name	Option Code	Reference Page
Brake	B	See P.105
Cable exit direction (Top)	CJT	See P.105
Cable exit direction (Right)	CJR	See P.105
Cable exit direction (Left)	CJL	See P.105
Cable exit direction (Bottom)	CJB	See P.105
Flange	FL	See P.106
Tip adapter (Internal thread)	NFA	See P.109
Non-motor end specification	NM	See P.110

# When selecting multiple options, please list them in alphabetical order. (e.g. B-CJB-NM)

### ③ Cable Length

Cable Type	Cable Code	RCP6	RCP6S
Standard	P (1m)	○	○
	S (3m)	○	○
	M (5m)	○	○
Specified Length	X06 (6m) ~X10 (10m)	○	○
	X11 (11m) ~X15 (15m)	○	○
	X16 (16m) ~X20 (20m)	○	○
	R01 (1m) ~R03 (3m)	○	○
Robot Cable	R04 (4m) ~R05 (5m)	○	○
	R06 (6m) ~R10 (10m)	○	○
	R11 (11m) ~R15 (15m)	○	○
	R16 (16m) ~R20 (20m)	○	○

\* Please refer to P.144 for more information regarding the maintenance cables.

## Actuator Specifications

Item	Description
Drive system	Ball screw φ16mm, rolled C10
Positioning repeatability	±0.01mm
Lost motion	0.1mm or less
Rod	φ40mm Aluminum
Rod non-rotation precision*	0 deg.
Allowable load and torque on rod tip	See P. 127
Rod tip overhang distance	150mm
Ambient operating temp. & humidity	0~40°C, 85% RH or less (Non-condensing)

\* Rod's angular displacement in rotational direction with no load applied to the rod.

Dimensions

CAD drawings can be downloaded from our website.  
www.intelligentactuator.com



- \*1 When the rod is returning to its home position, please be careful of interference from surrounding objects, as it will travel until it reaches the M.E. M.E: Mechanical end S.E: Stroke end
- \*2 The direction of width across flats varies depending on the product.
- \*3 When fixing the actuator using a front bracket or flange, please make sure that there is no external force applied to the main body.

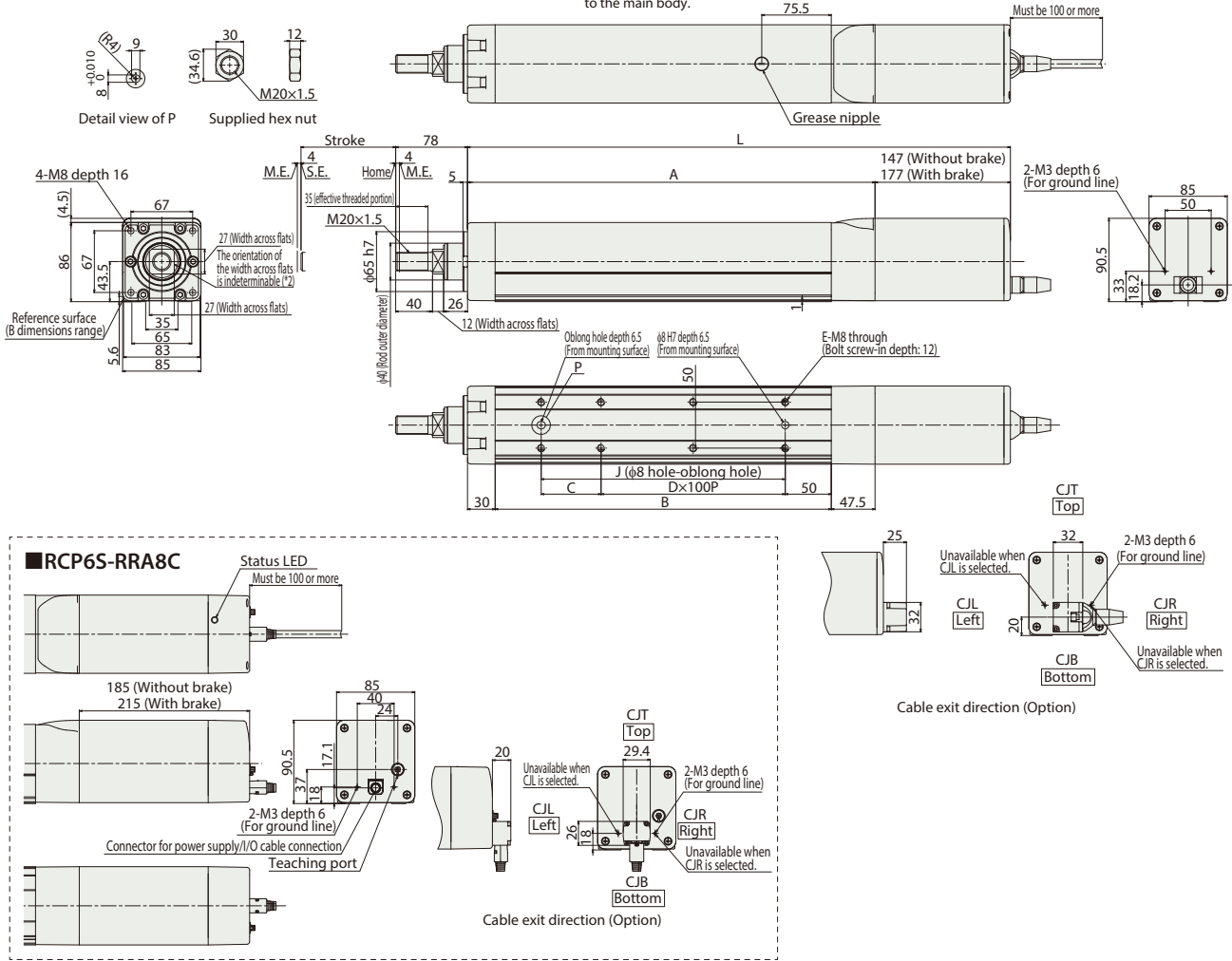

■ Rod Deflection of RCP6(S)-RRR8C (Reference Values)

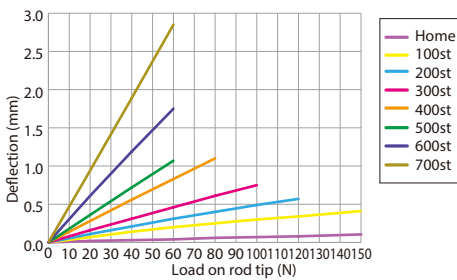

■ Dimensions and Mass by Stroke

L	Stroke	Stroke														
		50	100	150	200	250	300	350	400	450	500	550	600	650	700	
RCP6	w/o brake	439.5	489.5	539.5	589.5	639.5	689.5	739.5	789.5	839.5	889.5	939.5	989.5	1,039.5	1,089.5	
	w/ brake	469.5	519.5	569.5	619.5	669.5	719.5	769.5	819.5	869.5	919.5	969.5	1,019.5	1,069.5	1,119.5	
RCP6S	w/o brake	477.5	527.5	577.5	627.5	677.5	727.5	777.5	827.5	877.5	927.5	977.5	1,027.5	1,077.5	1,127.5	
	w/ brake	507.5	557.5	607.5	657.5	707.5	757.5	807.5	857.5	907.5	957.5	1,007.5	1,057.5	1,107.5	1,157.5	
A		292.5	342.5	392.5	442.5	492.5	542.5	592.5	642.5	692.5	742.5	792.5	842.5	892.5	942.5	
	B	215	265	315	365	415	465	515	565	615	665	715	765	815	865	
C		115	65	115	65	115	65	115	65	115	65	115	65	115	65	
	D	0	1	1	2	2	3	3	4	4	5	5	6	6	7	
E		4	6	6	8	8	10	10	12	12	14	14	16	16	18	
	J	115	165	215	265	315	365	415	465	515	565	615	665	715	765	
Allowable static load on rod tip (N)		222	186	159	139	124	111	101	92.1	84.7	78.4	72.8	68	63.7	59.8	
Allowable dynamic load on rod tip (kg)		9.5	7.8	6.6	5.7	5.0	4.5	4.0	3.6	3.3	3.0	2.8	2.6	2.4	2.2	
Load offset 100mm		7.4	6.3	5.5	4.9	4.4	4.0	3.6	3.3	3.0	2.8	2.6	2.4	2.2	2.1	
Allowable static torque on rod tip (N·m)		22.3	18.7	16.1	14.1	12.6	11.3	10.3	9.4	8.7	8.1	7.6	7.1	6.7	6.3	
Allowable dynamic torque on rod tip (N·m)		7.2	6.2	5.4	4.8	4.3	3.9	3.5	3.2	3.0	2.7	2.5	2.4	2.2	2.0	
Mass (kg)	RCP6	w/o brake	6.6	7.1	7.6	8.0	8.5	9.0	9.5	9.9	10.4	10.9	11.4	11.8	12.3	12.8
		w/ brake	7.2	7.7	8.2	8.6	9.1	9.6	10.1	10.5	11.0	11.5	11.9	12.4	12.9	13.4
	RCP6S	w/o brake	7.0	7.4	7.9	8.4	8.8	9.3	9.8	10.3	10.7	11.2	11.7	12.1	12.6	13.1
		w/ brake	7.5	8.0	8.5	9.0	9.4	9.9	10.4	10.8	11.3	11.8	12.3	12.7	13.2	13.7

② Applicable Controllers

The RCP6 series actuators can be operated by the controllers indicated below. Please select the type depending on your intended use. \* Please refer to P.147 for more information about the built-in controller of RCP6S series.

Name	External view	Max. number of controlled axes	Input power	Positioner	Pulse train	Program	Control method		Maximum number of positioning points	Reference page	
							Network *Option				
PCON-CFB/CGFB		1	DC24V	● *Option	● *Option	-	DeviceNet CC-Link PROFINET	CompoNet MEDIANET EtherCAT	EtherNet/IP EtherCAT	512 (768 for network spec.)	Please see P.131