

RCP6(S)-RA8R

Battery-less Absolute Motor Unit Type Side-mounted Motor Body Width 85* mm 24v Stepper Motor

Model Specification Items	Series	Type	Encoder Type	Motor Type	Lead	Stroke	Applicable Controller/I/O Type	Cable Length	Options
	RA8R	WA	60P						
	RCP6: Separate Controller RCP6S: Built-in Controller		WA: Battery-less Absolute	60P: Stepper Motor 60□ Size	20: 20mm 10: 10mm 5: 5mm	50: 50mm 1 300: 300mm (50mm increments)	[RCP6] P4: PCON- CFB/CGFB [RCP6S] SE: SIO Type	N : None P : 1m S : 3m M : 5m X□ : Specified Length R□ : Robot Cable	Please refer to the options table below. *Please make sure to specify ML, MR or MT when ordering the side-mounted motor type.

* RCP6 does not include a controller. RCP6S includes a built-in controller.
* Please refer to P.11 for more information about the model specification items.

* Body width does not include the width of the side-mounted motor.

CE RoHS

Horizontal Vertical Side Ceiling

*Depending on the model, there may be some limitations to using the vertical, side, and ceiling mount positions. Please contact IAI for more information regarding mounting positions.



The figure above is the motor side-mounted to the left (ML).

- POINT Selection Notes**
- (1) The maximum acceleration/deceleration is 0.1G for lead 5 and 0.2G for lead 10/20.
 - (2) The actuator specification displays the payload's maximum value, but it will vary depending on the acceleration and speed. Please refer to the "Selection Guidelines" (RCP6 Tables of Payload by Speed/Acceleration) on P.115 for more details.
 - (3) The value of the horizontal payload assumes that there is an external guide. Please be aware that the anti-rotation stopper can be damaged when an external force is applied to the rod from any direction other than the moving direction.
 - (4) When performing push-motion operation, please confirm the push force of each model by checking the "Correlation diagram of push force and current limit" on P.113.
 - (5) For RCP6S (built-in controller type), please limit the duty cycle to 70% or less.
 - (6) The service life of an actuator varies depending on the payload when using vertically. Please refer to P. 114 for more information.

Correlation Diagrams of Speed and Payload

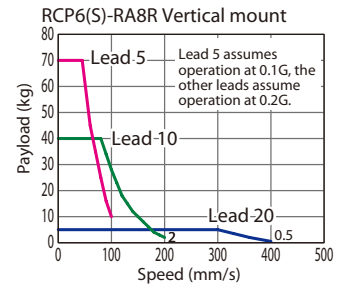
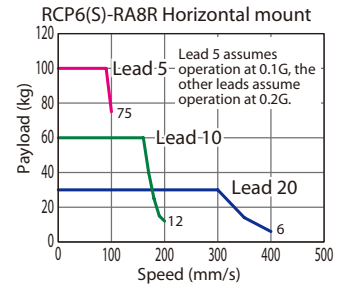

Actuator Specifications

Lead and Payload

Model Number	Lead (mm)	Max. Payload		Stroke (mm)
		Horizontal (kg)	Vertical (kg)	
RCP6(S)-RA8R-WA-60P-20-①-②-③-④	20	30	5	50~300 (The increment of stroke is 50mm)
RCP6(S)-RA8R-WA-60P-10-①-②-③-④	10	60	40	
RCP6(S)-RA8R-WA-60P-5-①-②-③-④	5	100	70	

Legend: ① Stroke ② Applicable controller/I/O type ③ Cable length ④ Options

Stroke and Max. Speed

(Unit: mm/s)

Lead (mm)	50~300 (Every 50mm)
20	400
10	200
5	100

① Stroke

Stroke (mm)	RCP6	RCP6S	Stroke (mm)	RCP6	RCP6S
50	○	○	200	○	○
100	○	○	250	○	○
150	○	○	300	○	○

④ Options

Name	Option Code	Reference Page
Brake	B	See P.105
Cable exit direction (Outside)	CJO	See P.105
Flange	FL	See P.106
Foot bracket	FT	See P.107
Motor side-mounted to the left	ML	See P.109
Motor side-mounted to the right	MR	See P.109
Motor side-mounted to the top	MT	See P.109
Tip adapter (Internal thread)	NFA	See P.109
Non-motor end specification	NM	See P.110
T-slot nut bar	NTB	See P.110

When selecting multiple options, please list them in alphabetical order. (e.g. B-CJB-NM)

③ Cable Length

Cable Type	Cable Code	RCP6	RCP6S
Standard	P (1m)	○	○
	S (3m)	○	○
	M (5m)	○	○
Specified Length	X06 (6m) ~X10 (10m)	○	○
	X11 (11m) ~X15 (15m)	○	○
	X16 (16m) ~X20 (20m)	○	○
	R01 (1m) ~R03 (3m)	○	○
Robot Cable	R04 (4m) ~R05 (5m)	○	○
	R06 (6m) ~R10 (10m)	○	○
	R11 (11m) ~R15 (15m)	○	○
	R16 (16m) ~R20 (20m)	○	○

* Please refer to P.144 for more information regarding the maintenance cables.

Actuator Specifications

Item	Description
Drive system	Ball screw φ16mm, rolled C10
Positioning repeatability	±0.01mm
Lost motion	0.1mm or less
Rod	φ40mm Material: Aluminum with hard alumite treatment
Static allowable torque on rod tip	5N·m
Max. angular displacement on rod tip (*1)	±0.8 deg.
Ambient operating temp. & humidity	0~40°C, 85% RH or less (Non-condensing)

(*1) This is the displacement angle of the rod tip (initial reference value) when the rod is fully retracted and the static allowable torque is applied at the rod tip.

Dimensions

CAD drawings can be downloaded from our website.
www.intelligentactuator.com



*1 When the rod is returning to its home position, please be careful of interference from surrounding objects, as it will travel until it reaches the M.E.
M.E: Mechanical end S.E: Stroke end
*2 The direction of width across flats varies depending on the product.

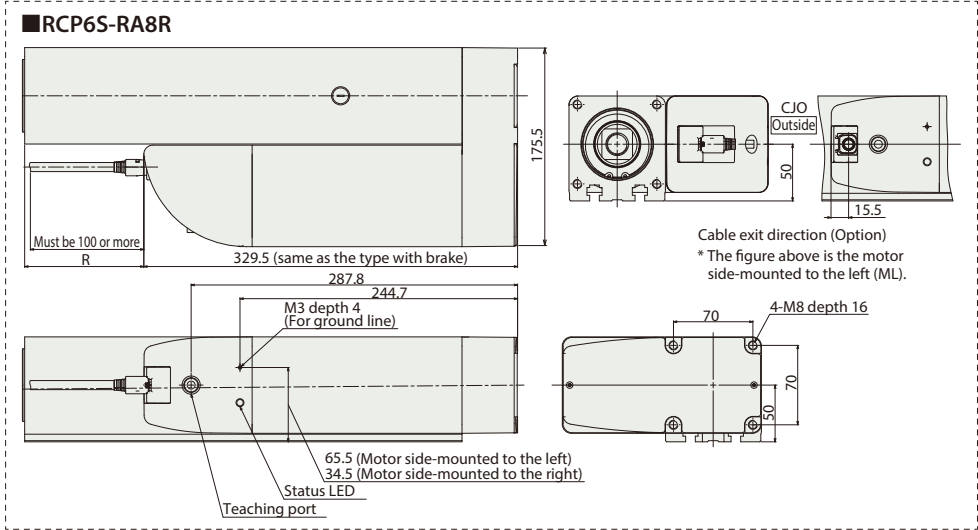
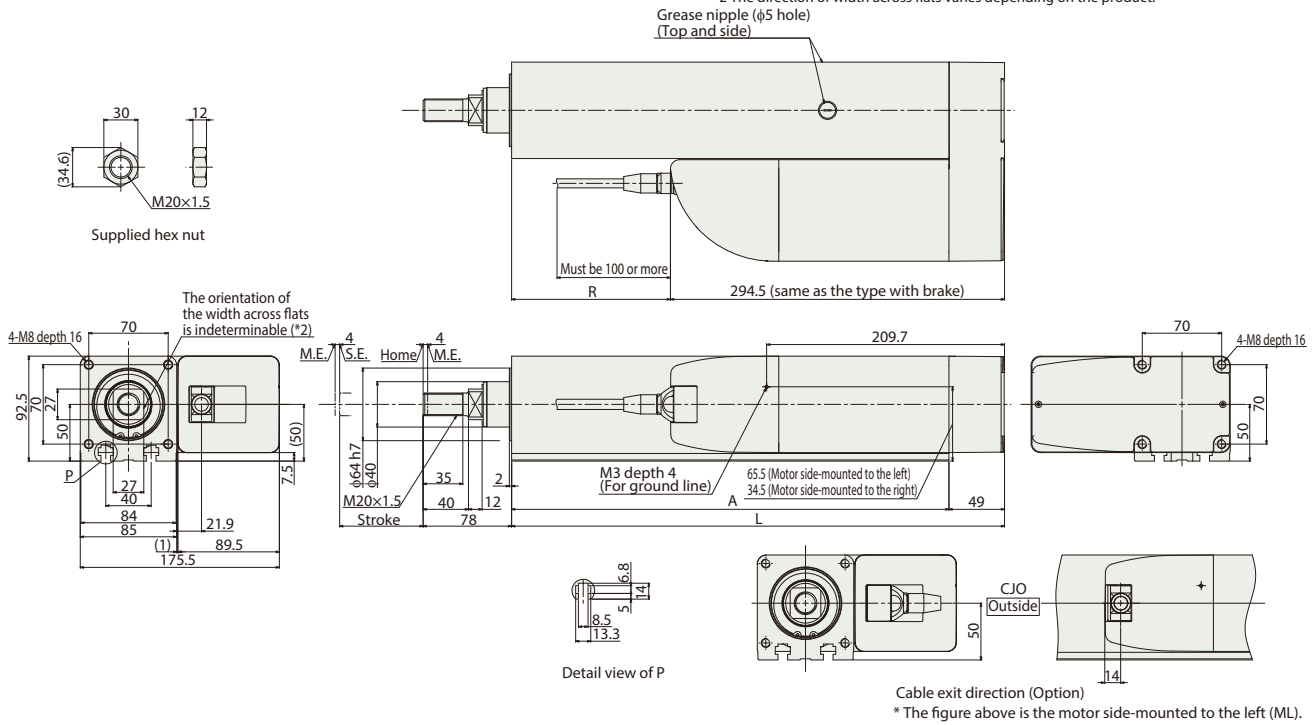

Note:
* If the length for R is negative in the table below, the length of the actuator body is shorter than the motor unit.

■ Dimensions and Mass by Stroke

		Stroke	50	100	150	200	250	300
R	L	284.5	334.5	384.5	434.5	484.5	534.5	
	A	235.5	285.5	335.5	385.5	435.5	485.5	
	RCP6S	-45	5	55	105	155	205	
Mass (kg)	RCP6	w/o brake	9.0	9.9	10.8	11.7	12.6	13.5
		w/brake	9.2	10.1	11.0	11.9	12.8	13.7
	RCP6S	w/o brake	9.2	10.1	11.0	11.9	12.8	13.7
		w/brake	9.4	10.3	11.2	12.1	13.0	13.9

② Applicable Controllers

The RCP6 series actuators can be operated by the controllers indicated below. Please select the type depending on your intended use. * Please refer to P.147 for more information about the built-in controller of RCP6S series.

Name	External view	Max. number of controlled axes	Input power	Positioner	Pulse train	Program	Control method		Maximum number of positioning points	Reference page	
							Network *Option				
PCON-CFB/CGFB		1	DC24V	● *Option	● *Option	-	DeviceNet CC-Link PROFINET	CompoNet MEDIANET EtherCAT	EtherNet/IP PROFINET	512 (768 for network spec.)	Please see P.131