

RCP5-RA8C ROBO Cylinder, High-thrust Rod Type, Motor Unit Coupled, Actuator Width 88mm, 24V Pulse Motor

Model	RCP5	RA8C	WA	60P			P4		
Specification Items	Series	Type	Encoder type	Motor type	Lead	Stroke	Applicable controller	Cable length	Options
			WA: Battery-less absolute specification	60P: Pulse motor, size 60□	20: 20mm 10: 10mm 5: 5mm	50: 50mm 700: 700mm (Every 50mm)	P4: PCON-CFA	N: No cable P: 1m S: 3m M: 5m X□: Specified length R□: Robot cable	Please refer to the options table below.

*Controller is not included.

Radial Load Applicable

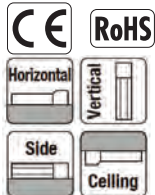

* Depending on the model, there may be some limitations to using the vertical mount position. Please refer to P.59 for details.



- POINT**
Note on selection
- (1) The payload assumes operation at an acceleration of 0.1G for lead 5 and operation at an acceleration of 0.2G for lead 10 and lead 20. The above values are the upper limits of acceleration/deceleration.
 - (2) Please note that the RA8C requires a dedicated controller (high-thrust PCON-CFA).
 - (3) The radial cylinder is equipped with a built-in guide. Please refer to the graphs shown in P. 65 and after for the allowable load mass.

Correlation Diagrams of Speed and Payload

RCP5-RA8C, Horizontal mount, PCON-CFA connected

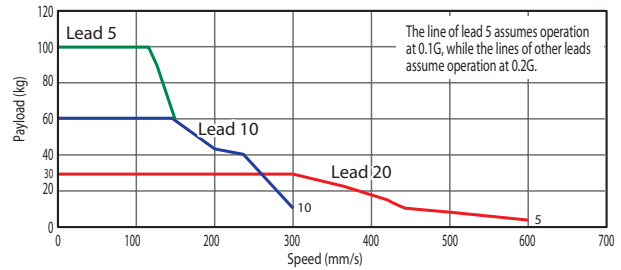

RCP5-RA8C, Vertical mount, PCON-CFA connected

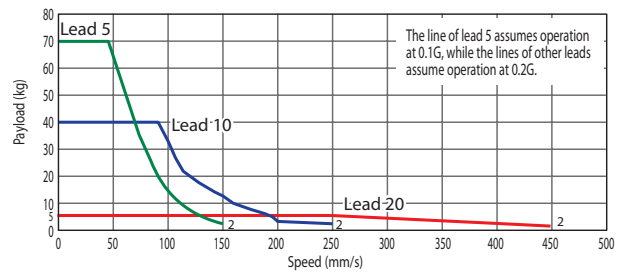

Actuator Specifications

Lead and Payload

Model number	Lead (mm)	Connected controller	Maximum payload		Maximum push force (N)	Stroke (mm)
			Horizontal (kg)	Vertical (kg)		
RCP5-RA8C-WA-60P-20-①-P4-②-③	20	PCON-CFA	30	5	500	50~700 (Every 50mm)
RCP5-RA8C-WA-60P-10-①-P4-②-③	10	PCON-CFA	60	40	1,000	
RCP5-RA8C-WA-60P-5-①-P4-②-③	5	PCON-CFA	100	70	2,000	

Legend: ① Stroke ② Cable length ③ Options *Please refer to P. 59 for push-motion operation.

Stroke and Maximum Speed

Values in brackets <> are for vertical use. (Unit: mm/s)

Lead (mm)	50 (mm)	100 (mm)	150 (mm)	200 (mm)	250~350 (mm)	400 (mm)	450 (mm)	500 (mm)	550 (mm)	600 (mm)	650 (mm)	700 (mm)
20	280	405	505 <450>	585 <450>	600 <450>	520 <450>	440	360	320	280	240	220
10	280 <250>	300 <250>		260 <250>		220	180	160	140	120	110	
5	150			130		110	90	80	70	60	55	

① Stroke

Stroke (mm)	Standard price	Stroke (mm)	Standard price
50	-	400	-
100	-	450	-
150	-	500	-
200	-	550	-
250	-	600	-
300	-	650	-
350	-	700	-

② Cable Length

Type	Cable code	Standard price
Standard type	P (1m)	-
	S (3m)	-
	M (5m)	-
Special length	X06 (6m) ~X10 (10m)	-
	X11 (11m)~X15 (15m)	-
	X16 (16m)~X20 (20m)	-
	R01 (1m) ~R03 (3m)	-
Robot cable	R04 (4m) ~R05 (5m)	-
	R06 (6m) ~R10 (10m)	-
	R11 (11m)~R15 (15m)	-
	R16 (16m)~R20 (20m)	-

*Please refer to P. 89 for maintenance cables.

③ Options

Name	Option code	Reference page	Standard price
Brake	B	→P. 11	-
Cable exit direction (Top)	CJT	→P. 11	-
Cable exit direction (Right)	CJR	→P. 11	-
Cable exit direction (Left)	CJL	→P. 11	-
Cable exit direction (Bottom)	CJB	→P. 11	-
Flange	FL	→P. 12	-
Non-motor end specification	NM	→P. 11	-

Actuator Specifications

Item	Description
Drive system	Ball screw Ø16mm, rolled C10
Positioning repeatability	±0.02mm
Lost motion	0.1mm or less
Rod	Ø40mm Aluminum
Rod non-rotation precision (*1)	0 deg.
Allowable load and torque on rod tip	Refer to table in the page on the right, refer to P. 65
Rod tip overhang distance	100mm or less
Ambient operating temperature, humidity	0 to 40°C, 85% RH or less (Non-condensing)

(*1) Rod's angular displacement in rotational direction with no applied load is shown.

Dimensions

CAD drawings can be downloaded from our website. www.intelligentactuator.com



- *1 When the rod is returning to its home position, please be careful of interference from surrounding objects, as it will travel until it reaches the ME.
- *2 The direction of width across flats varies depending on the product.
- *3 If the actuator is installed using the front housing and flange, make sure the actuator will not receive any external force.
ME: Mechanical end
SE: Stroke end

■ Dimensions with Flange (Option)

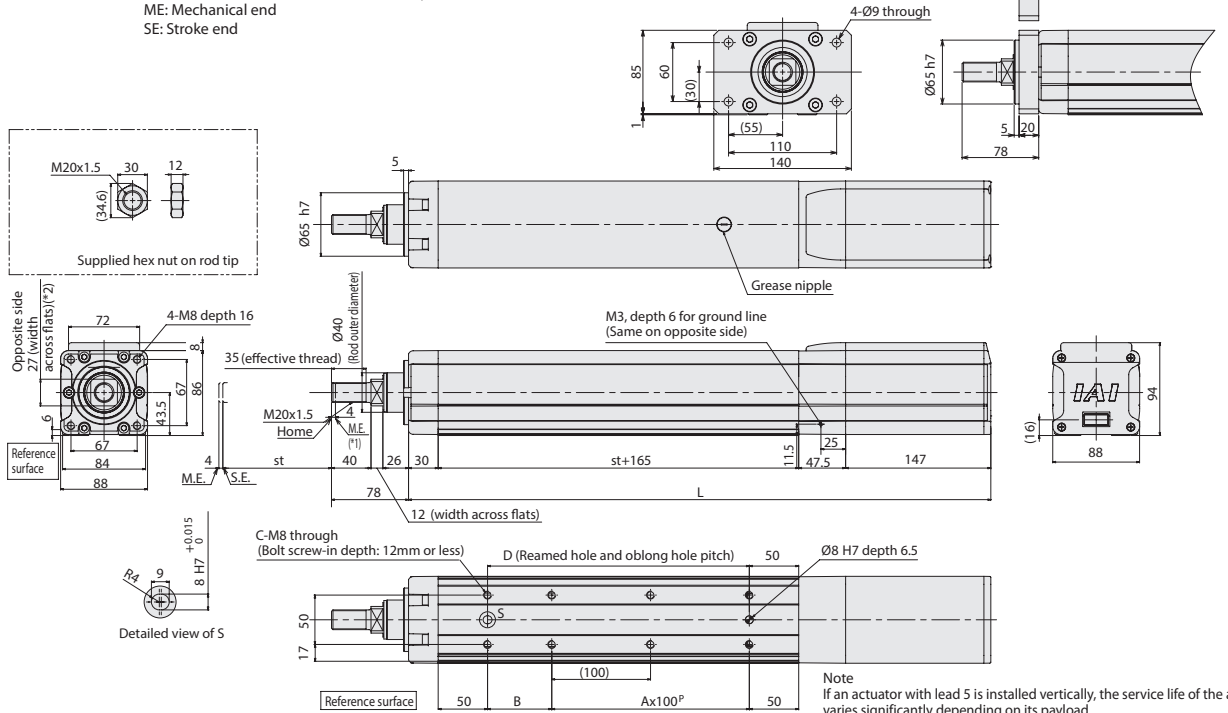

■ Dimensions with Brake (Option)

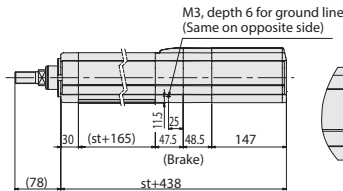

■ 4 Cable Exit Directions (Option)

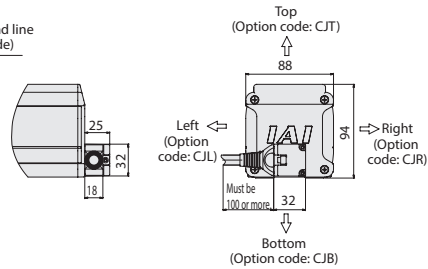

Note
If an actuator with lead 5 is installed vertically, the service life of the actuator varies significantly depending on its payload.
Please refer to the correlation diagram of vertical load and traveling life shown below.
(If the actuator is installed horizontally, its service life is not affected by the payload.)

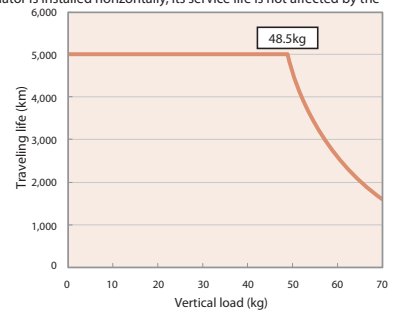

■ Rod Deflection of RCP5-RA8C

(The graph below shows the measurements of how much a horizontally installed rod would deflect when a load is applied to the end of the rod. The measured deflection includes the deflection due to the weight of the rod.)

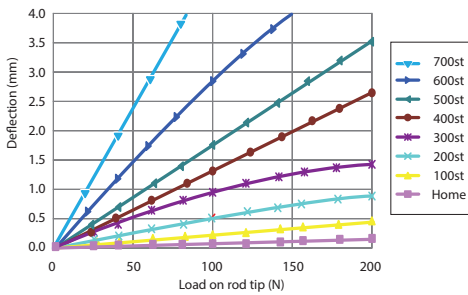

■ Dimensions and Mass by Stroke

Stroke	L														
	50	100	150	200	250	300	350	400	450	500	550	600	650	700	
Without brake	439.5	489.5	539.5	589.5	639.5	689.5	739.5	789.5	839.5	889.5	939.5	989.5	1,039.5	1,089.5	
	488	538	588	638	688	738	788	838	888	938	988	1,038	1,088	1,138	
A	0	1	1	2	2	3	3	4	4	5	5	6	6	7	
B	115	65	115	65	115	65	115	65	115	65	115	65	115	65	
C	4	6	6	8	8	10	10	12	12	14	14	16	16	18	
D	115	165	215	265	315	365	415	465	515	565	615	665	715	765	
Allowable static load on rod tip (N)	180	150.3	128.9	112.7	99.9	89.7	81.3	74.3	68.3	63.1	58.6	54.6	51.1	47.9	
	73.6	60.3	51.0	44.1	38.7	34.3	30.7	27.7	25.2	23.0	21.1	19.4	17.8	16.5	
Allowable dynamic load on rod tip (N)	57.0	48.6	42.5	37.8	33.8	30.5	27.6	25.2	23.1	21.2	19.5	18.1	16.7	15.5	
	18.1	15.2	13.0	11.4	10.2	9.2	8.4	7.7	7.1	6.6	6.1	5.8	5.4	5.1	
Allowable static torque on rod tip (N·m)	5.7	4.9	4.3	3.8	3.4	3.0	2.8	2.5	2.3	2.1	2.0	1.8	1.7	1.5	
	7.1	7.6	8.0	8.4	8.9	9.3	9.7	10.2	10.6	11.0	11.4	11.9	12.3	12.7	
Mass (kg)	Without brake	7.1	7.6	8.0	8.4	8.9	9.3	9.7	10.2	10.6	11.0	11.4	11.9	12.3	12.7
	With brake	8.3	8.7	9.1	9.6	10.0	10.4	10.9	11.3	11.7	12.1	12.6	13.0	13.4	13.9

Applicable Controllers

The RCP5 series actuators can be operated by the controllers indicated below. Please select the type depending on your intended use.

Name	External view	Model number	Maximum number of positioning points	Input power	Standard price	Reference page
Positioner type		PCON-CFA-60PWAI-NP-2-0 PCON-CFA-60PWAI-PN-2-0	512 points	DC24V	-	→P. 69
Pulse-train type		PCON-CFA-60PWAI-PLN-2-0 PCON-CFA-60PWAI-PLP-2-0	—			
Field network type		PCON-CFA-60PWAI-①-0-0	768 points			

① Field network specification code (DV, CC, PR, CN, ML, EC, EP)