

RCS2-SRGD7BD

ROBO Cylinder Rod Type with Double Guide 75mm Diameter 200V Servo Motor Short-Length Model

■ Configuration: **RCS2 -SRGD7BD - I**

Series	Type	Encoder	Motor	Lead	Stroke	Compatible Controllers	Cable Length	Option
		I : Incremental	60 : 60W Servo Motor 100 : 100W Servo Motor 150 : 150W Servo Motor	16 : 16mm 8 : 8mm 4 : 4mm	50 : 50mm 300 : 300mm (50mm pitch increments)	T1 : XSEL-J/K T2 : SCON SSEL XSEL-P/Q	N : None P : 1m S : 3m M : 5m X □ □ : Custom R □ □ : Robot cable	See Options below

* See page Pre-35 for an explanation of the naming convention.



Technical References P. A-5



- (1) When operated at the rated acceleration, the maximum load capacity is the load capacity at the rated acceleration.
- (2) When operated at the maximum acceleration, the maximum load capacity is the load capacity at the maximum acceleration.
- (3) The values for the horizontal load capacity assume the use of an external guide, so that there is no external force from any direction other than the forward/backward direction of the rod.
See the technical resources (page A-83) for the allowable weight using the supplied guide alone.

Actuator Specifications

Lead and Load Capacity

Model	Motor Output (W)	Lead (mm)	Rated Acceleration (G)	Load Capacity at Rated Acceleration		Max. Acceleration (G)	Load Capacity at Max. Acceleration		Rated Thrust (N)	Stroke (mm)
				Horizontal (kg)	Vertical (kg)		Horizontal (kg)	Vertical (kg)		
RCS2-SRGD7BD-I-60-16-①-②-③-④	60	16	0.25	5	1	0.35	2.5	(N/A)	63	50~300 (50mm increments)
RCS2-SRGD7BD-I-60-8-①-②-③-④		8	0.15	10	4	0.25	5	1.5	127	
RCS2-SRGD7BD-I-60-4-①-②-③-④		4	0.05	20	9	0.15	10	4	254	
RCS2-SRGD7BD-I-100-16-①-②-③-④	100	16	0.3	10	2.5	0.4	5	0.5	103	
RCS2-SRGD7BD-I-100-8-①-②-③-④		8	0.2	22	8	0.3	10	3.5	207	
RCS2-SRGD7BD-I-100-4-①-②-③-④		4	0.1	40	18.5	0.2	20	8	414	
RCS2-SRGD7BD-I-150-16-①-②-③-④	150	16	0.3	15	5.5	0.4	7.5	2	157	
RCS2-SRGD7BD-I-150-8-①-②-③-④		8	0.2	35	13.5	0.3	17.5	6	314	
RCS2-SRGD7BD-I-150-4-①-②-③-④		4	0.1	55	21.5	0.2	27.5	10	628	

Legend ① Stroke ② Compatible controller ③ Cable length ④ Options

Stroke and Maximum Speed

Lead	Stroke (50 ~ 300 (50mm increments))	
	Stroke	50 ~ 300
16	800	
8	400	
4	200	

(Unit: mm/s)

① Stroke List

Stroke (mm)	Standard Price		
	Motor Output (W)		
	60W	100W	150W
50	-	-	-
100	-	-	-
150	-	-	-
200	-	-	-
250	-	-	-
300	-	-	-

③ Cable List

Type	Cable Symbol	Standard Price
Standard	P (1m)	-
	S (3m)	-
	M (5m)	-
Special Lengths	X06 (6m) ~ X10 (10m)	-
	X11 (11m) ~ X15 (15m)	-
	X16 (16m) ~ X20 (20m)	-
	R01 (1m) ~ R03 (3m)	-
Robot Cable	R04 (4m) ~ R05 (5m)	-
	R06 (6m) ~ R10 (10m)	-
	R11 (11m) ~ R15 (15m)	-
	R16 (16m) ~ R20 (20m)	-

* See page A-39 for cables for maintenance.

④ Option List

Name	Option Code	See Page	Standard Price
Connector cable exit direction	A1 ~ A3	→ A-25	-
Brake	B	→ A-25	-
Foot bracket	FT	→ A-29	-

Actuator Specifications

Item	Description
Drive System	Ball screw ø12mm C10 grade
Positioning Repeatability	±0.02mm
Lost Motion	0.1mm or less
Guide	Double guide (guide rod diameter ø16, Ball bush type)
Rod Diameter	ø35mm
Non-rotating accuracy of rod	±0.08 deg
Ambient Operating Temp./Humidity	0 ~ 40°C, 85% RH or less (non-condensing)

Dimensions

CAD drawings can be downloaded from IAI website. www.intelligentactuator.com

For Special Orders P. A-9



*The SRGD7BD is not available in reversed-home configuration, due to its construction.

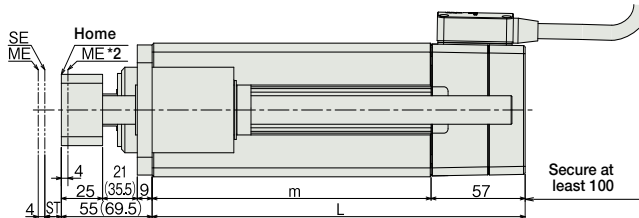
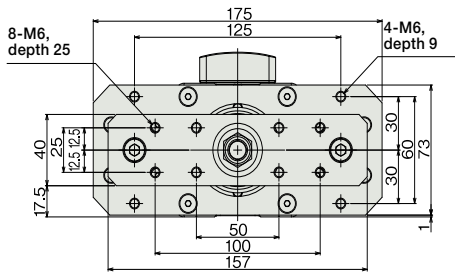

* For brake-equipped model, see standard type (see P242)

* The value inside () is the dimension for the extended rod tip model.

Note:
A slit is provided in the side of the actuator body to prevent pauses due to forward/backward operation.
Please make a separate request for a dustproof/splash-proof model.

- *1: The motor-encoder cable is connected here. See page A-39 for details on cables.
 - *2: When homing, the rod moves to the mechanical end position; therefore, please watch for any interference with the surrounding objects.
- ST: Stroke
SE: Stroke end
ME: Mechanical end

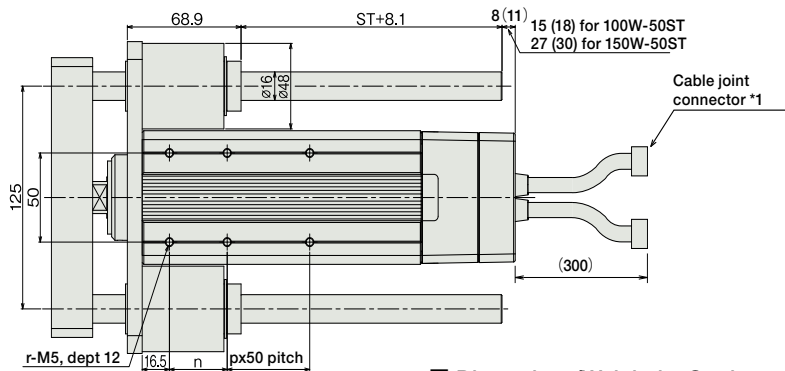

■ Dimensions/Weight by Stroke

Stroke		50	100	150	200	250	300
L	60W	126	176	226	276	326	376
	100W	133	176	226	276	326	376
	150W	145	176	226	276	326	376
m	60W	69	119	169	219	269	319
	100W	76	119	169	219	269	319
	150W	88	119	169	219	269	319
n		25	35	35	35	35	35
p		0	0	1	2	3	4
r		4	4	6	8	10	12
Weight (kg)	60W	4.3	5	5.7	6.4	7.2	7.9
	100W	4.5	5.1	5.9	6.6	7.3	8
	150W	4.8	5.3	6.1	6.8	7.5	8.2

② Compatible Controllers

The RCS2 series actuators can operate with the controllers below. Select the controller according to your usage.

Name	External View	Model	Description	Max. Positioning Points	Input Voltage	Power Supply Capacity	Standard Price	See Page
Positioner Mode		SCON-C-①I-NP-2-②	Positioning is possible for up to 512 points	512 points	Single-Phase AC 100V Single-Phase AC 200V Three-phase AC 200V (XSEL-P/Q only)	360VA max. * When operating a 150W single-axis model	-	→ P547
Solenoid Valve Mode			Operable with the same controls as the solenoid valve.	7 points				
Serial Communication Type			Dedicated to serial communication	64 points				
Pulse Train Input Control Type			Dedicated to Pulse Train Input	(-)				
Program Control 1-2 Axes Type		SSEL-C-1-①I-NP-2-②	Programmed operation is possible. Operation is possible on up to 2 axes	20000 points			-	→ P577
Program Control 1-6 Axes Type		XSEL-③-1-①I-N1-EEE-2-④	Programmed operation is possible. Operation is possible on up to 6 axes	20000 points			-	→ P587

Note: The SRGD7BD type actuator cannot be connected to the 5th and 6th axis of the XSEL-P/Q controller.

- * For SSEL and XSEL, only applicable to the single-axis model.
- * ① is a placeholder for the motor output (W) (60, 100, 150).
- * ② is a placeholder for the power supply voltage (1: 100V, 2: single-phase 200V).
- * ③ is a placeholder for the XSEL type name ("J", "K", "P", or "Q").
- * ④ is a placeholder for the power supply voltage (1: 100V, 2: single-phase 200V, or 3: three-phase 200V).

- Slider Type
- Mini
- Standard
- Controllers Integrated
- Rod Type
- Mini
- Standard
- Controllers Integrated
- Table/Arm/Flat Type
- Mini
- Standard
- Controllers Integrated
- Gripper/Rotary Type
- Linear Servo Type
- Cleanroom Type
- Splash Proof
- Controllers
- PMEC/AMEC
- PSEP/ASEP
- ROBO NET
- ERC2
- PCON
- ACON
- SCON
- PSEL
- ASEL
- SSEL
- XSEL
- Pulse Motor
- Servo Motor (24V)
- Servo Motor (200V)
- Linear Servo Motor