

RCA2-GD4N

ROBO Cylinder Mini Rod Type Short-Length Free Mounting Type with Double Guide
34mm Width 24V Servo Motor Ball Screw/Lead Screw

■ Configuration: **RCA2** — **GD4N** — **I** — **20** — **30** — **30** — **30** — **30**

Series	Type	Encoder	Motor	Lead	Stroke	Compatible Controllers	Cable Length	Option
		I: Incremental * The Simple absolute encoder is also considered type "I".	20 : 20W Servo Motor	6: 6mm ball screw 4: 4mm ball screw 2: 2mm ball screw 6S: 6mm lead screw 4S: 4mm lead screw 2S: 2mm lead screw	30 : 30mm	A1 : ACON RACON ASEL A3 : AMEC ASEP	N : None P : 1m S : 3m M : 5m X □□ : Custom	K2 : Connector Cable exit direction LA : Power-saving

* See page Pre-35 for an explanation of the naming convention.



Power-saving

Technical References P. A-5

- POINT**
Notes on Selection
- (1) The horizontal load capacity is based on the use of a guide to prevent any radial and/or moment load on the rod. If no guide will be installed, see the Tip Load vs. Service Life graph (→ page A-82).
 - (2) The load capacity is based on operation at an acceleration of 0.3G (0.2G for the 2mm-lead model, lead screw model, or when used vertically). This is the upper limit of the acceleration.
 - (3) When using the lead screw model, please use it for applications that are suitable for its characteristics. (See page Pre-42 for more information.)

Actuator Specifications

■ Lead and Load Capacity

Model	Motor Output (W)	Feed Screw	Lead (mm)	Max. Load Capacity		Rated Thrust (N)	Positioning Repeatability (mm)	Stroke (mm)
				Horizontal (kg)	Vertical (kg)			
RCA2-GD4N-I-20-6-30-①-②-③	20	Ball Screw	6	2	0.5	33.8	±0.02	30
RCA2-GD4N-I-20-4-30-①-②-③			4	3	0.75	50.7		
RCA2-GD4N-I-20-2-30-①-②-③			2	6	1.5	101.5		
RCA2-GD4N-I-20-6S-30-①-②-③	20	Lead Screw	6	0.25	0.125	19.9	±0.05	30
RCA2-GD4N-I-20-4S-30-①-②-③			4	0.5	0.25	29.8		
RCA2-GD4N-I-20-2S-30-①-②-③			2	1	0.5	59.7		

Legend ① Compatible controller ② Cable length ③ Options

■ Stroke and Maximum Speed

Lead	Stroke	
	6 (mm)	30 (mm)
Ball Screw	6	270 <220>
	4	200
	2	100
Lead Screw	6	220
	4	200
	2	100

* The values enclosed in < > apply for vertical usage. (Unit: mm/s)

Stroke List

Stroke (mm)	Standard Price	
	Feed Screw	
	Ball Screw	Lead screw
30	-	-

② Cable List

Type	Cable Symbol	Standard Price
Standard (Robot Cables)	P (1m)	-
	S (3m)	-
	M (5m)	-
Special Lengths	X06 (6m) ~ X10 (10m)	-
	X11 (11m) ~ X15 (15m)	-
	X16 (16m) ~ X20 (20m)	-
		-

* The RCA2 comes standard with a robot cable.

* See page A-39 for cables for maintenance.

③ Option List

Name	Option Code	See Page	Standard Price
Connector cable exit direction	K2	→ A-32	-
Power-saving	LA	→ A-32	-

Actuator Specifications

Item	Description
Drive System	Ball screw/lead screw ø6mm C10 grade
Lost Motion	Ball screw: 0.1mm or less/lead screw: 0.3mm or less (initial value)
Frame	Material: Aluminum (white alumite treated)
Ambient Operating Temp./Humidity	0~40°C, 85% RH or less (non-condensing)
Service Life	Lead Screw: Horizontal: 10 million cycles Vertical: 5 million cycles

Dimensions

CAD drawings can be downloaded from IAI website. www.intelligentactuator.com

For Special Orders P. A-9

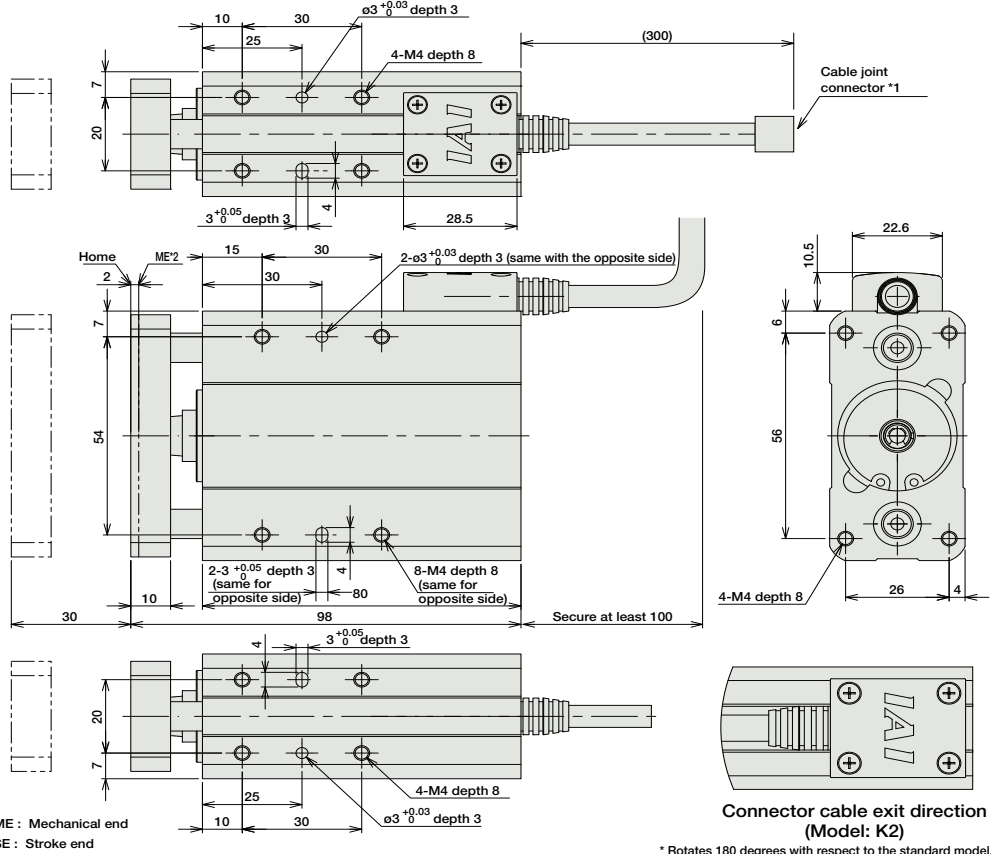
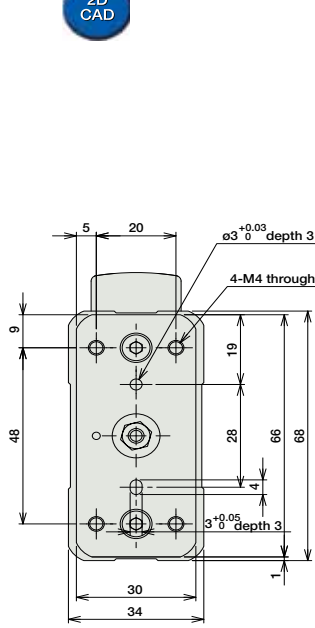

ME : Mechanical end
SE : Stroke end

Connector cable exit direction (Model: K2)

* Rotates 180 degrees with respect to the standard model.

- *1 A motor-encoder cable is connected here. See page A-39 for details on cables.
- *2 When homing, the rod moves to the mechanical end; therefore, please watch for any interference with the surrounding objects.

■ Dimensions/Weight by Stroke

Stroke	30
Weight (kg)	0.64

① Compatible Controllers

The RCA2 series actuators can operate with the controllers below. Select the controller according to your usage.

Name	External View	Model	Description	Max. Positioning Points	Input Voltage	Power Supply Capacity	Standard Price	See Page
Solenoid Valve Type		AMEC-C-20①-NP-2-1	Easy-to-use controller, even for beginners	3 points	AC100V	2.4A rated	-	→ P477
Splash-Proof Solenoid Valve Type		ASEP-C-20①-NP-2-0 ASEP-CW-20①-NP-2-0	Operable with same signal as solenoid valve. Supports both single and double solenoid types. No homing necessary with simple absolute type.				-	→ P487
Positioner Type		ACON-C-20①-NP-2-0	Positioning is possible for up to 512 points	512 points	DC24V	(Standard) 1.3A rated 4.4A max. (Power-saving) 1.3A rated 2.5A max.	-	→ P535
Safety-Compliant Positioner Type		ACON-CG-20①-NP-2-0					-	
Pulse Train Input Type (Differential Line Driver)		ACON-PL-20①-NP-2-0	Pulse train input type with differential line driver support	(-)	DC24V	(Standard) 1.3A rated 4.4A max. (Power-saving) 1.3A rated 2.5A max.	-	→ P535
Pulse Train Input Type (Open Collector)		ACON-PO-20①-NP-2-0	Pulse train input type with open collector support				-	
Serial Communication Type		ACON-SE-20①-N-0-0	Dedicated to serial communication	64 points			-	
Field Network Type		RACON-20①	Dedicated to field network	768 points			-	→ P503
Program Control Type		ASEL-C-1-20①-NP-2-0	Programmed operation is possible. Operation is possible on up to 2 axes	1500 points			-	→ P567

* This is for the single-axis ASEL.
* ① is a placeholder for the code "LA" if the power-saving option is specified.

- Slider Type
- Mini
- Standard
- Controllers Integrated
- Rod Type
- Mini
- Standard
- Controllers Integrated
- Table/Arm/Flat Type
- Mini
- Standard
- Gripper/Rotary Type
- Linear Servo Type
- Cleanroom Type
- Splash Proof
- Controllers
- PMEC/AMEC
- PSEP/ASEP
- ROBO NET
- ERC2
- PCON
- ACON
- SCON
- PSEL
- ASEL
- SSEL
- XSEL
- Pulse Motor
- Servo Motor (24V)
- Servo Motor (200V)
- Linear Servo Motor