

RCP3-RA2BR

ROBO Cylinder Mini Rod Type Side-Mounted Motor 28mm Width
Pulse Motor Lead Screw

■ Configuration: **RCP3** — **RA2BR** — **I** — **20P** — — — — —

Series — Type — Encoder — Motor — Lead — Stroke — Compatible Controllers — Cable Length — Option

I: Incremental
* The Simple absolute encoder is also considered type "I".

20P: Pulse motor
20 □ size

6S: 6mm lead screw
4S: 4mm lead screw
2S: 2mm lead screw

25: 25mm
150: 150mm (25mm pitch increments)

P1: PCON
RPCON
PSEL
P3: PMEC
PSEP

N: None
P: 1m
S: 3m
M: 5m
X □ □: Custom Length

See Options below
* Be sure to specify which side the motor is to be mounted (ML/MR).

* See page Pre-35 for an explanation of the naming convention.

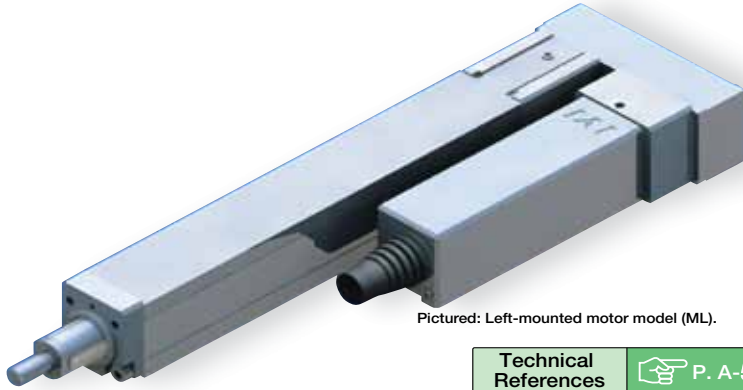

Pictured: Left-mounted motor model (ML).

Technical References P. A-5

- POINT**
Notes on Selection
- (1) The load capacity is based on operation at an acceleration of 0.2G. This is the upper limit of the acceleration.
 - (2) The horizontal load capacity is based on the use of an external guide. If an external force is exerted on the rod from a direction other than the motion of the rod, the detent may become damaged.
 - (3) The maximum pushing force is exerted at 5mm/s.
 - (4) If the actuator is used in a dusty environment, its service life will become significantly shorter.
 - (5) This model uses a lead screw. Please ensure that your usage is appropriate for its characteristics. (See page Pre-42 for more information.)

Speed vs. Load Capacity

Due to the characteristics of the pulse motor, the RCP3 series' load capacity decreases at high speeds. In the table below, check if your desired speed and load capacity are supported.

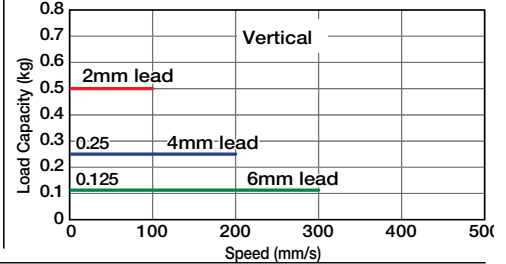
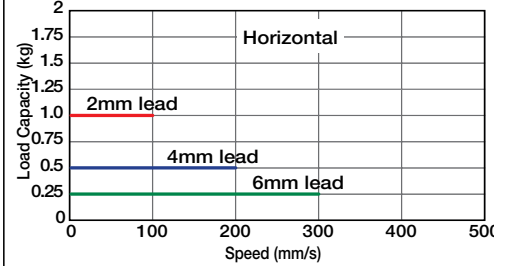

Actuator Specifications

Lead and Load Capacity

Model	Feed Screw	Lead (mm)	Max. Load Capacity		Maximum Push Force (N)	Positioning Repeatability (mm)	Stroke (mm)
			Horizontal (kg)	Vertical (kg)			
RCP3-RA2BR-I-20P-6S-①-②-③-④	Lead Screw	6	0.25	0.125	See page A-68.	±0.05	25 ~ 150 (25mm increments)
RCP3-RA2BR-I-20P-4S-①-②-③-④		4	0.5	0.25			
RCP3-RA2BR-I-20P-2S-①-②-③-④		2	1	0.5			

Legend ① Stroke ② Compatible controller ③ Cable length ④ Options

Stroke and Maximum Speed

Stroke / Lead	Stroke (mm)	Maximum Speed (mm/s)		
		25 (mm)	50 (mm)	75 ~ 150 (mm)
Lead Screw	6	180	280	300
	4	180	200	
	2	100		

(Unit: mm/s)

① Stroke List

Stroke (mm)	Standard Price	
	Feed Screw	Lead Screw
25	-	-
50	-	-
75	-	-
100	-	-
125	-	-
150	-	-

③ Cable List

Type	Cable Symbol	Standard Price
Standard (Robot Cables)	P (1m)	-
	S (3m)	-
	M (5m)	-
Special Lengths	X06 (6m) ~ X10 (10m)	-
	X11 (11m) ~ X15 (15m)	-
	X16 (16m) ~ X20 (20m)	-
	-	-

* The RCP3 comes standard with a robot cable.

* See page A-39 for cables for maintenance.

④ Option List

Name	Option Code	See Page	Standard Price
Brake	B	→ A-25	-
Left-Mounted Motor (Standard)	ML	→ A-33	-
Right-Mounted Motor	MR	→ A-33	-
Reversed-home	NM	→ A-33	-

Actuator Specifications

Item	Description
Drive System	Lead screw ø6mm C10 grade
Lost Motion	0.3mm or less (initial value)
Base	Material: Aluminum (white alumite treated)
Guide	Sliding guide
Ambient Operating Temp./Humidity	0 ~ 40°C, 85% RH or less (non-condensing)
Service Life	Horizontal: 10 million cycles Vertical: 5 million cycles

Dimensions

CAD drawings can be downloaded from IAI website. www.intelligentactuator.com



* The diagram below shows a left-mounted motor model.

For Special Orders P. A-9

(with brake)

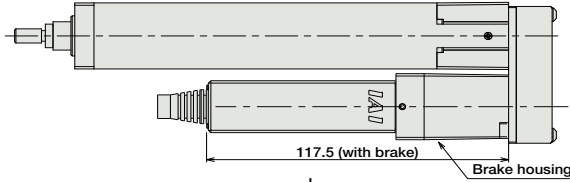

(without brake)

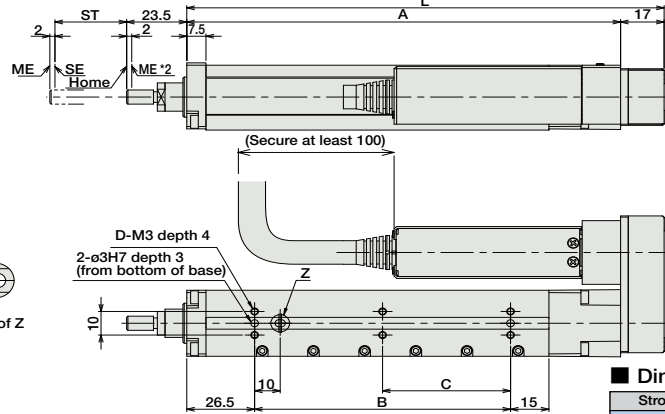
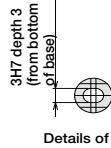
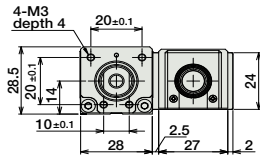
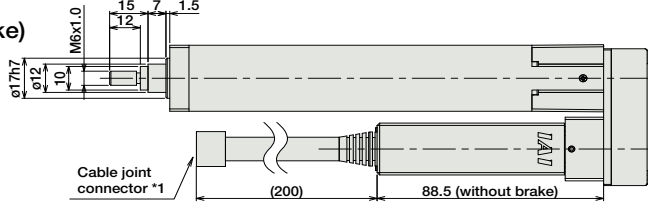

ST : Stroke
ME : Mechanical end
SE : Stroke end

* Adding a brake will increase the actuator's weight by 0.1kg.

■ Dimensions/Weight by Stroke

Stroke	25	50	75	100	125	150
L	111.5	136.5	161.5	186.5	211.5	236.5
A	94.5	119.5	144.5	169.5	194.5	219.5
B	25	50	75	100	125	150
C	0	0	0	50	62.5	75
D	4	4	4	6	6	6
Weight (kg)	0.33	0.37	0.4	0.43	0.46	0.49

② Compatible Controllers

The RCP3 series actuators can operate with the controllers below. Select the controller according to your usage.

Name	External View	Model	Description	Max. Positioning Points	Input Voltage	Power Supply Capacity	Standard Price	See Page
Solenoid Valve Type		PMEC-C-20PI-NP-2-①	Easy-to-use controller, even for beginners	3 points	AC100V AC200V	See P481	-	→ P477
		PSEP-C-20PI-NP-2-0	Operable with same signal as solenoid valve. Supports both single and double solenoid types. No homing necessary with simple absolute type.					
Splash-Proof Solenoid Valve Type		PSEP-CW-20PI-NP-2-0						
Positioner Type		PCON-C-20PI-NP-2-0	Positioning is possible for up to 512 points	512 points	DC24V	2A max.	-	→ P525
Safety-Compliant Positioner Type		PCON-CG-20PI-NP-2-0						
Pulse Train Input Type (Differential Line Driver)		PCON-PL-20PI-NP-2-0	Pulse train input type with differential line driver support	(-)	DC24V	2A max.	-	→ P525
Pulse Train Input Type (Open Collector)		PCON-PO-20PI-NP-2-0	Pulse train input type with open collector support					
Serial Communication Type		PCON-SE-20PI-N-0-0	Dedicated to serial communication	64 points				
Field Network Type		RPCON-20P	Dedicated to field network	768 points				→ P503
Program Control Type		PSEL-C-1-20PI-NP-2-0	Programmed operation is possible. Operation is possible on up to 2 axes	1500 points				→ P557

* This is for the single-axis PSEL.

* ① is a placeholder for the power supply voltage (1: 100V, or 2: 100~240V).

- Slider Type
- Mini
- Standard
- Controllers Integrated
- Rod Type
- Mini
- Standard
- Controllers Integrated
- Table/Arm/Flat Type
- Mini
- Standard
- Gripper/Rotary Type
- Linear Servo Type
- Cleanroom Type
- Splash Proof
- Controllers
- PMEC/AMEC
- PSEP/ASEP
- ROBO NET
- ERC2
- PCON
- ACON
- SCON
- PSEL
- ASEL
- SSEL
- XSEL
- Pulse Motor
- Servo Motor (24V)
- Servo Motor (200V)
- Linear Servo Motor